

# Technical data sheet

## Flow meter FMO



More than just pumps

### Flow meter FMO



#### Advantages/characteristics:

- ▶ Oval rotor design
- ▶ For low-viscosity to high-viscosity media
- ▶ With integrated digital display unit FLUXTRONIC® or available as pulse version
- ▶ Depending on type for use with drum/eccentric worm-drive pump or for use in piping
- ▶ Flow rate of 0,04 - 380 l/min
- ▶ High accuracy and repeat accuracy
- ▶ Signal transduction at FLUXTRONIC® or other external control e. g. PCC possible
- ▶ Display in litre, gallon or kilogram possible
- ▶ Semiautomatic filling in connection with a switching amplifier possible
- ▶ For Ex-application in zone 1

Technical data/type	FMO 101			FMO 102			FMO 104		
	P/P	P/S	S/S	P/P	P/S	S/S	AL/P	S/P	S/S
Description									
Connection inlet/outlet				G ¼			G ½		
<b>Material</b>									
Housing	PVDF	PVDF	S	PVDF	PVDF	S	AL	S	S
Oval rotors	PPS	S	S	PPS	S	S	LCP	LCP	S
Shaft	HC	S	S	HC	S	S	S	S	S
Seal	FKM/FFKM/EPDM								
Viscosity max. [mPas]	up to 1 000						up to 1 000 / from 1 000 up to 500 000		
Flow rate l/min at viscosity < 5 mPas at viscosity > 5 mPas < 1 000	0,09-1,67 0,04-1,67			0,44-8,3 0,25-8,3			2-25 1-30		
Measurement error of the flow rate <sup>(1)</sup> < 5 mPas > 5 mPas	± 2,5 % ± 1 %						± 2 % ± 0,5 %		
Repeat accuracy <sup>(2)</sup>	± 0,03 %								
Pulse/litre (theo.)	2170			390			100		
Theo. calibration constant [L/lmp]	0,0004608			0,0025641			0,0100000		
Medium temperature [°C] (for non Ex-application and Ex-application with pulse version)	-10 to +60	-30 to +120		-10 to +60	-30 to +120		-30 to +80	-30 to +120	
Medium temperature [°C] (for Ex-application with FLUXTRONIC®)	-						-20 to +40		
Ambient temperature [°C]	-20 to +40								
Operating pressure max. [bar]	10	100		10	100		130	200	
Protection class [IP]	54								
Ex-marking	II 2 G Ex c TX								
Weight [kg]	0,2	0,2	0,7	0,2	0,2	0,6	1,6	4,1	4,2
Sensor	Reed/Hall						Reed/Reed*		

<sup>(1)</sup> Difference between the average measured values of a series of the measurements and the theoretical value

<sup>(2)</sup> Bandwidth between several measurements under identical conditions

\* Version Reed/Reed or Hall/Hall possible

# Technical data sheet

## Flow meter FMO 110/140/150

Technical data/type	FMO 110				FMO 140			FMO 150		
Description	P/P	AL/P	S/P	S/S	AL/P	S/P	S/S	AL/P	S/P	S/S
Connection inlet/outlet	G 1				Flange DIN 1092 PN16/DN40 A150/ LK110/ holes 4xø18			Flange DIN 1092 PN16/DN50 A165/ LK125/ holes 4xø18		
<b>Material</b>										
Housing	PVDF	AL	S	S	AL	S	S	AL	S	S
Oval rotors	PPS	PPS	PPS	S	PPS	PPS	S	PPS	PPS	S
Shaft	HC	S	S	S	S	S	S	S	S	S
Seal	FKM / FFKM / EPDM									
Viscosity max. [mPas]	up to 1 000 / from 1 000 up to 500 000									
Flow rate l/min at viscosity < 5 mPas at viscosity > 5 mPas < 1 000	9,5-150 5,7-170				15-227 9,5-245			23-380 15-380		
Measurement error of the flow rate <sup>(1)</sup> < 5 mPas > 5 mPas	± 2 % ± 0,5 %				± 1 % ± 0,5 %					
Repeat accuracy <sup>(2)</sup>	± 0,03 %									
Pulse/litre (theo.)	45				17			9		
Theo. calibration constant [L/lmp]	0,0222222				0,0588235			0,1111111		
Medium temperature [°C] (for non Ex-application and Ex-application with pulse version)	-10 to +60	-30 to +80		-30 to +120	-30 to +80		-30 to +120	-30 to +80		-30 to +120
Medium temperature [°C] (for Ex-application with FLUXTRONIC®)	-10 to +40	-20 to +40								
Ambient temperature [°C]	-20 to +40									
Operating pressure max. [bar]	10	130	200		16					
Protection class [IP]	54									
Ex-marking	II 2 G Ex c TX									
Weight [kg]	1,5	1,7	4,3	4,5	5,1	13,4	13,9	5,8	15,2	16,2
Sensor	Reed/Reed*									

<sup>(1)</sup> Difference between the average measured values of a series of the measurements and the theoretical value

<sup>(2)</sup> Bandwidth between several measurements under identical conditions

\* Version Reed/Reed or Hall/Hall possible

# Dimensions

## Flow meter FMO

### Dimensions [mm]

#### FMO 101/102 (without FLUXTRONIC®)

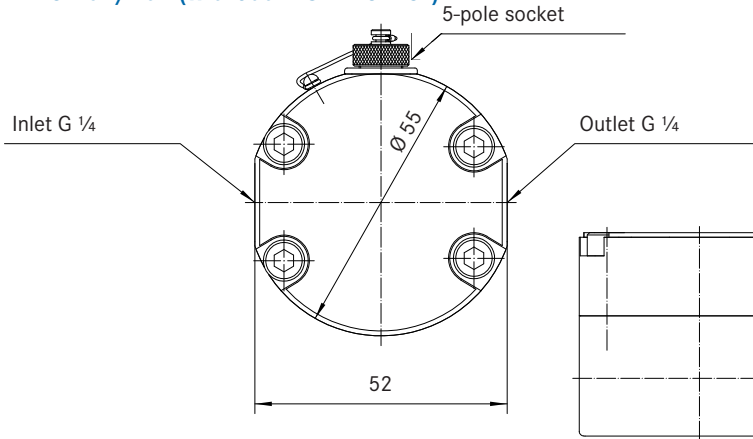

Measure	H	Z
FMO 101/102 P	48	16
FMO 101/102 S	44	13

#### FMO 104/110 (with FLUXTRONIC®)

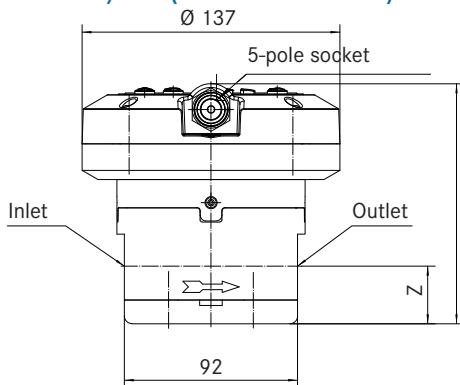

Measure	H	Z
FMO 104	128	31
FMO 110	139	39

#### FMO 104/110 in pulse version (without FLUXTRONIC®)

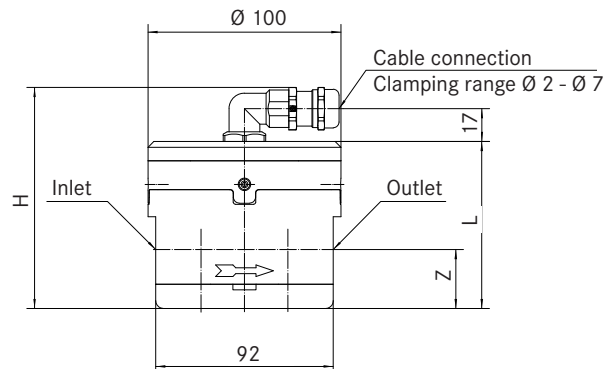

Measure	H	Z	L
FMO 104	115	31	87
FMO 110	126	39	98

#### FMO 140/150 (with FLUXTRONIC®)

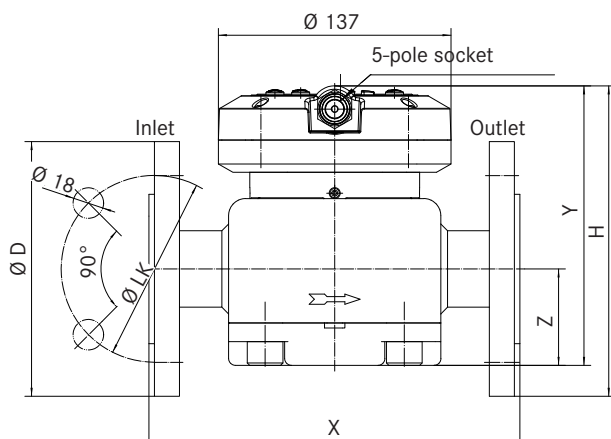

Measure	Ø D	Lk	H	X	Y	Z
FMO 140	150	110	183	212	165	57
FMO 150	165	125	196,5	264	175	61

# Part numbers

## Flow meter FMO



More than just pumps

### For media with viscosities up to 1 000 mPas

#### Flow meter with FLUXTRONIC®

Material	Seal	FMO 104	FMO 110	FMO 140	FMO 150
AL/P	EPDM	A06 04 100	A06 10 100	A06 40 101	A06 50 101
	FKM	A06 04 110	A06 10 110	A06 40 111	A06 50 111
	FFKM	A06 04 120	A06 10 120	A06 40 121	A06 50 121
S/P	EPDM	A06 04 200	A06 10 200	A06 40 201	A06 50 201
	FKM	A06 04 210	A06 10 210	A06 40 211	A06 50 211
	FFKM	A06 04 220	A06 10 220	A06 40 221	A06 50 221
S/S	EPDM	A06 04 300	A06 10 300	A06 40 301	A06 50 301
	FKM	A06 04 310	A06 10 310	A06 40 311	A06 50 311
	FFKM	A06 04 320	A06 10 320	A06 40 321	A06 50 321
P/P	EPDM	-	A06 10 400	-	-
	FKM	-	A06 10 410	-	-
	FFKM	-	A06 10 420	-	-

#### Flow meter in pulse version (without FLUXTRONIC®)

Material	Seal	FMO 101	FMO 102	FMO 110	Material	Seal	FMO 104	FMO 110
P/S	EPDM	AB6 01 100	AB6 02 100	-	AL/P	EPDM	AB6 04 100	AB6 10 100
	FKM	AB6 01 110	AB6 02 110	-		FKM	AB6 04 110	AB6 10 110
	FFKM	AB6 01 120	AB6 02 120	-		FFKM	AB6 04 120	AB6 10 120
S/S	EPDM	AB6 01 300	AB6 02 300	-	S/P	EPDM	AB6 04 200	AB6 10 200
	FKM	AB6 01 310	AB6 02 310	-		FKM	AB6 04 210	AB6 10 210
	FFKM	AB6 01 320	AB6 02 320	-		FFKM	AB6 04 220	AB6 10 220
P/P	EPDM	AB6 01 400	AB6 02 400	AB6 10 400	S/S	EPDM	AB6 04 300	AB6 10 300
	FKM	AB6 01 410	AB6 02 410	AB6 10 410		FKM	AB6 04 310	AB6 10 310
	FFKM	AB6 01 420	AB6 02 420	AB6 10 420		FFKM	AB6 04 320	AB6 10 320

### For media with viscosities from 1 000 mPas to max. 500 000 mPas

#### Flow meter with FLUXTRONIC®

Material	Seal	FMO 104	FMO 110	FMO 140	FMO 150
AL/PV	EPDM	A06 04 105	A06 10 105	A06 40 106	A06 50 106
	FKM	A06 04 115	A06 10 115	A06 40 116	A06 50 116
	FFKM	A06 04 125	A06 10 125	A06 40 126	A06 50 126
S/PV	EPDM	A06 04 205	A06 10 205	A06 40 206	A06 50 206
	FKM	A06 04 215	A06 10 215	A06 40 216	A06 50 216
	FFKM	A06 04 225	A06 10 225	A06 40 226	A06 50 226
S/SV	EPDM	A06 04 305	A06 10 305	A06 40 306	A06 50 306
	FKM	A06 04 315	A06 10 315	A06 40 316	A06 50 316
	FFKM	A06 04 325	A06 10 325	A06 40 326	A06 50 326

#### Flow meter in pulse version (without FLUXTRONIC®)

FMO 104	FMO 110
AB6 04 105	AB6 10 105
AB6 04 115	AB6 10 115
AB6 04 125	AB6 10 125
AB6 04 205	AB6 10 205
AB6 04 215	AB6 10 215
AB6 04 225	AB6 10 225
AB6 04 305	AB6 10 305
AB6 04 315	AB6 10 315
AB6 04 325	AB6 10 325

#### Connecting piece made of stainless steel (S)

To connect	Connection	Part no.
FMO 104 - FLUX drum pump	G ½ A - G 1 ¼	959 06 143
FMO 104 - FLUX eccentric worm-drive pump	G ½ A - G 1 ½	959 06 134
FMO 110 - FLUX drum pump	G 1 A - G 1 ¼	959 06 144
FMO 110 - FLUX eccentric worm-drive pump	G 1 A - G 1 ½	959 06 122

#### Connecting piece made of polyvinylidene fluoride (PVDF)

To connect	Connection	Part no.
FMO 110 P/P - at FLUX drum pump	G 1 A - G 1 ¼	959 06 145

# Technical data sheet

## Digital display unit FLUXTRONIC®

### Digital display unit FLUXTRONIC®



#### Advantages/characteristics:

- ▶ Simple operating concept
- ▶ All data will be maintained when replacing the battery
- ▶ Four safety levels with PIN setting
- ▶ Three additional outlets
- ▶ For mounting on flow meters, on nozzles or e.g. on the wall
- ▶ Calibration on medium possible
- ▶ Shows filled quantity (normal operation)
- ▶ With switching amplifier batch mode possible (automatic mode)
- ▶ Ex-proofed

Technical data		
Ambient temperature	-20 to +40 °C (at temp. below 0 °C the LCD-display is slowed)	
Housing material	PP	
Pulse length	2 mS	
Power supply	Lithium battery CR 2032	
Protection class	IP 54	
Input	Mechanical contact (reedsensor) start/stop (button)	
Output	NAMUR: redirection, signal 1 – e. g. for motor, signal 2 – e. g. for valve, error signal OK signal	
Ex-marking	II 2G Ex ia IIB T6 Gb	
Description	Part no.	
External FLUXTRONIC® for flow meter in pulse version	001 42 113	
Protecting cap for FLUXTRONIC®	001 42 121	
Pulse cable for connecting the flow meter in pulse version with FLUXTRONIC®	5 m	934 08 032
	10 m	934 08 033
	15 m	934 08 034

Switching amplifier for non-Ex applications	
Description	Part no.
FSV 100 (2 signals*) for installation in flow meter	001 49 040
Connecting cable switching amplifier/motor	934 08 035
Connecting cable switching amplifier/magnetic valve	934 08 036
Switching amplifier for Ex-application	
Description	Part no.
FSV 121-1 Ex (2 signals*) for external mounting Ex-marking: II 2 G EEx de (ia) IIC T6	001 49 039
FSV 132 (2 signals*) for installation in the control cabinet Ex-marking: II (1) G [Ex ia Ga] IIC	940 04 020
FSV 133 Ex (1 signal) for installation in the control cabinet for redirection Ex-marking: II 3 (1) G Ex nAc nCc [ia] IIC T4	940 04 041
Control cable 5 m Flow meter/FSV	934 08 038
Control cable 10 m Flow meter/FSV	934 08 040

\* e. g. for switching the motor and valve

**Maximal flow rate (l/min) for different viscosities and x bar pressure drop**

Viscosity [mPas]	Pressure drop x [bar]	Type					
		FMO 101*	FMO 102*	FMO 104	FMO 110	FMO 140	FMO 150
1	1 *0,1 **0,5	1,67*	4*	23*	130	180**	380
< 140		0,24*	1,2*	7,6*	75	150	220
< 400		-	-	15,5	34	70	105
< 900		-	-	8,5	18	45	65
< 2.500	10	-	-	19	43	90	123
< 5.000		-	-	13	29	60	82
< 10.000		-	-	9	19	40	55
< 15.000		-	-	6	13	27	37
< 30.000		-	-	4	9	18	24
< 60.000		-	-	3	6	12	16
< 120.000		-	-	2	4	8	11
< 250.000		-	-	1	3	5	7
< 500.000		-	-	-	2	4	5

**Mounting position FMO**

When mounting the flow meter type FMO make sure that neither the bottom nor the cover of the meter housing will be ground off by the weight of the oval rotors.

