

Verderhus Stainless Steel

HSB-50-50-A



VERDERHUS®

Description

Verderhus stainless steel screw centrifugal pumps combine the best features of centrifugal and positive displacement pumps. They define a new standard for low head, high flow pumps. The Verderhus pumps have a large clearance screw impeller, which gently feeds product into the pump chamber. This allows the product to be efficiently transferred into the discharge line and allows for large solids to be easily pumped. The screw design impeller is ideal for high solid contents and viscous liquids. It produces a high efficiency, low NPSHr pump, lowering both energy usage and operational costs, generating a lower overall cost of ownership.

Features and benefits

- Large solid handling with <10% sludge, <30% slurry
- Gentle, low shear pumping, meaning lesser damage to the fluid
- Low energy use compared to other technologies
- Low abrasive wear meaning reduced maintenance costs
- Corrosion resistant stainless steel for aggressive chemical handling

Technical data

Ambient operating temperature	-5 to 40 °C	Max viscosity	3000 cP
Fluid temperature	-20 to 100 °C	Maximum solid size (pump specific)	40 mm
Maximum pump noise	up to 68 dB	Solid content percentage	sludge: 10% - slurry: 30%
Max. flows	40 m ³ /h	Max. head (Range specific)	13 mwc

Performance curve

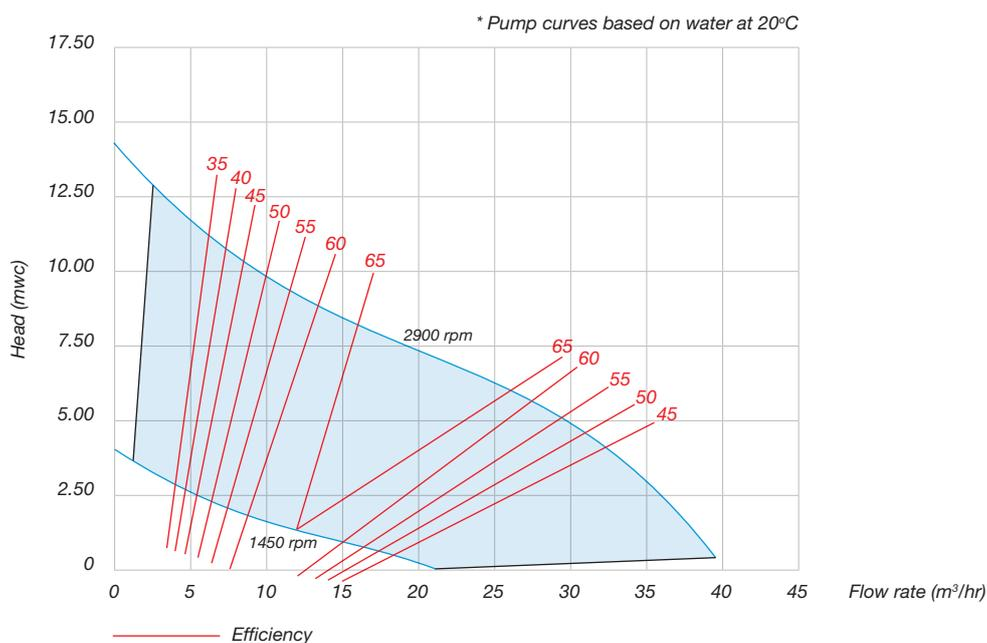

Verderhus Stainless Steel

HSB-50-50-A



VERDERHUS®

Item No.	Description	Standard Materials / Dimensions
1	Impeller housing/Cone	Stainless Steel 1.4408 (316)
	Suction flange	DN50 PN10
	Discharge flange	G2" BSPP
2	Impeller	Stainless Steel 1.4408 (316)
3	Bearing housing	Stainless Steel 1.4408 (316)
4	Transition flange	Stainless Steel 1.4408 (316)
5	Drive shaft	Stainless Steel 1.4435 (AISI 316L)
6	Bearing	Single Row Deep Groove Ball Race-Sealed for Life
7	Mechanical seal-product side	Silicon Carbide/Silicon Carbide/VITON
8	Mechanical seal-motor side	Carbon/Ceramic/NBR
9	Oil Chamber	Industrial gear oil 150
10	O-rings material	FPM
11	Motor options and overall pump weight (WEG W22 IE3 motors)	With IEC80 Motor: 37 Kg With IEC90 Motor: 45 Kg With IEC100 Motor: 52 Kg With IEC112 Motor: 75 Kg
	Mounting frame	Steel S275 JR

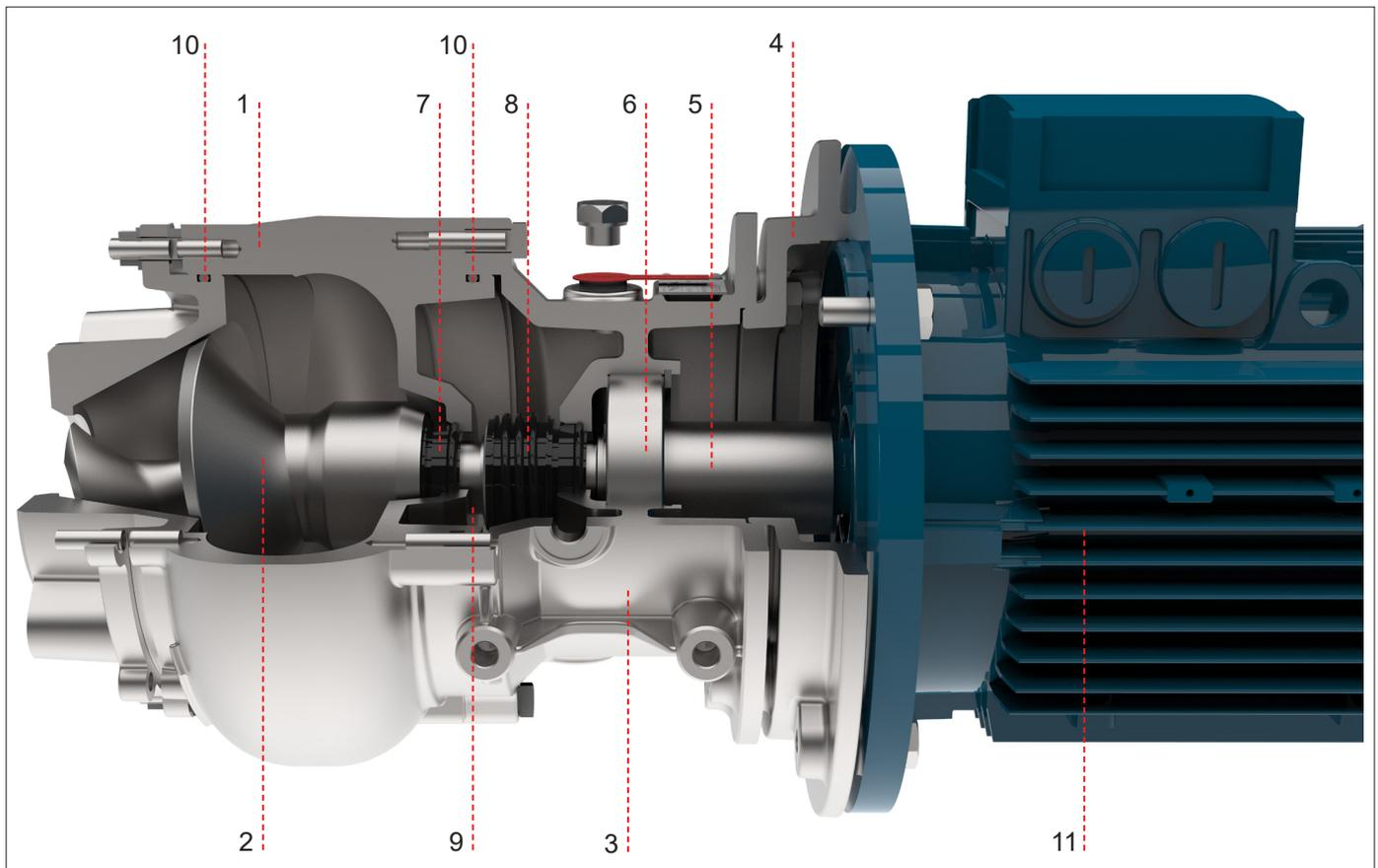

Sectional view of Impeller Housing Assembly



Verderhus Stainless Steel

HSB-50-50-A



VERDERHUS®

Dimensions

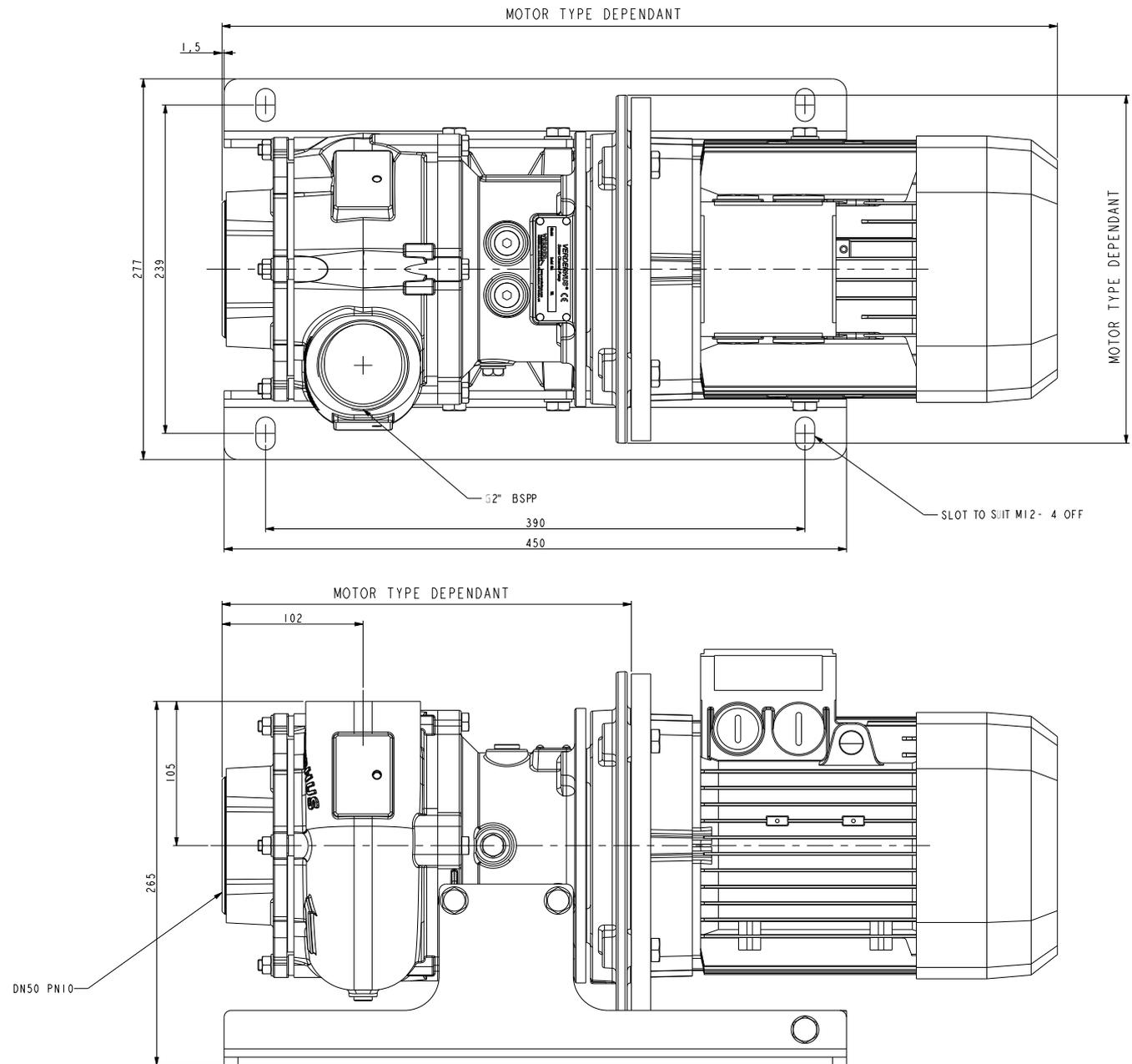

All dimensions are in mm.

All dimensions and weights are for guidance only.

136-VH-SS_HSB_50_50_A_Technosheet_rev01_2018_(eu)



Find your local supplier at www.verderhus.com

For construction, installation and floor mounting drawings please contact your local authorised Verderhus® distributor.

VERDER
passion for pumps