

KRACHT



Transfer Gear Pumps

KF 3/100 ... KF 6/730

Contents

Technical Data

	Page
Applications / Suitable fluids	3
Construction	4
Variants / Direction of rotation	5
ATEX design	6
Materials / Characteristics	7
Noise optimized	8 – 9
Technical data – Discharge flow / Input power	10
Type key	11

Dimension Sheets

Flange type pumps	12
Flange type pumps with pressure relief valve	13
Flange type pumps with mechanical seal	14
Flange type pumps with mechanical seal and pressure relief valve	15
Motor pump assemblies KF 3	16
Motor pump assemblies KF 4	17
Motor pump assemblies KF 5	18
Motor pump assemblies KF 6	19
Flange-type pumps with universal arrangement	20
Connecting flange	21
Couplings	22
Flange type pumps with mounting angle	23
Characteristic curves	24 – 26

Applications, Suitable Fluids

Applications

Centrifuge construction,
Coating machines, Compressors
Engine construction
Filling stations, Filter systems
Generator construction
Heat transfer systems, Heavy electrical machines
Lubricant manufacturers, Lubricating oil systems
Machine-building industry, Machine tools,
Manufacture of apparatus,
Marine engine construction,
Metal-forming machines, Metering systems
Paint industry, Plain metal bearing production,
Printing machines, PUR machinery
Refrigerators, Rubber and tire manufacturing
Tank plant construction,
Transmission building
Turbine construction
Vacuum machinery
Waste oil - disposal
 - transport
 - treatment

Suitable fluids

Adhesives, Antifreeze
Bore oils
Cutting oils
Diesel oils, Drawing compound
Emulsions
Fuel oils, L, EL, H
Gear oils, Grease
Hardening oils, Heat transfer media,
Heavy oils, Hydraulic fluids
Isocyanate
Lubricating oils, Lacquers
Motor oils
Paint, Paraffins, Plastics, Polyols
Printing inks, Processing oils
Resins, Rolling oils
Waste oils, Waxes

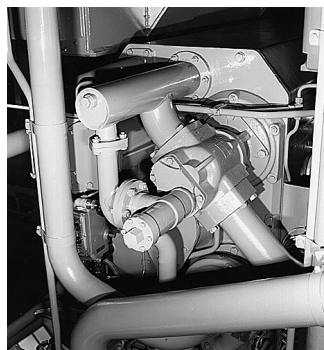
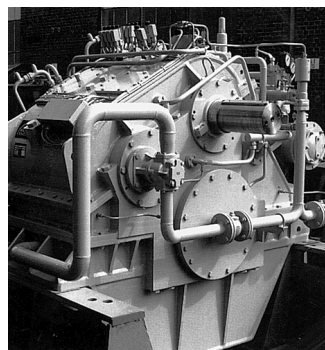
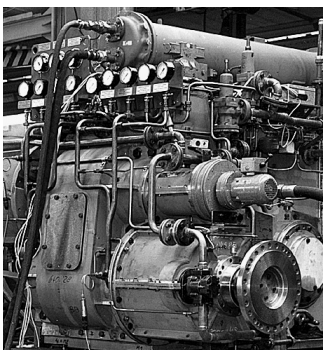
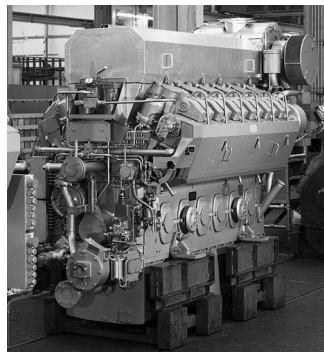

Construction

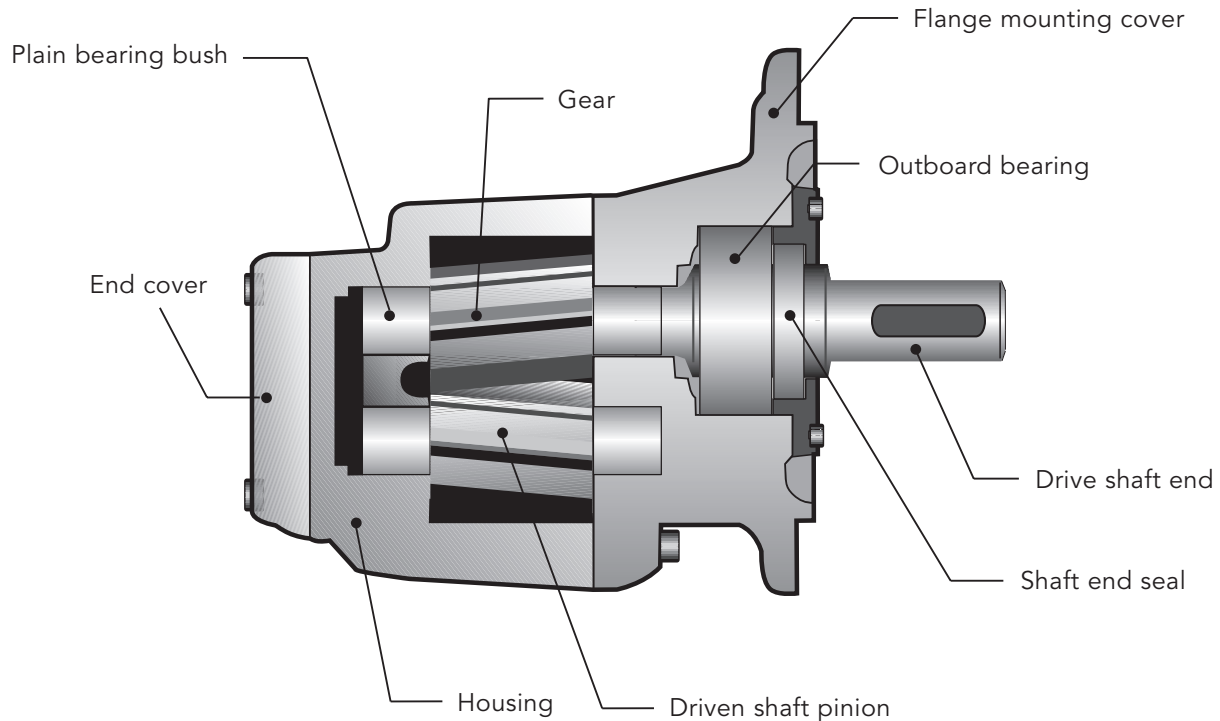

Function

KF gear pumps are used for pumping a wide variety of fluids.

KF gear pumps are distinguished especially by their wide range of variants which are assembled as required on the modular principle and also permit subsequent upgrade.

The pumps are also suitable for media with low lubricating properties.

The standard housing sections are of grey cast iron. The gear units are manufactured from high strength case hardening steel, hardened and mounted in special multicomponent plain bearing bushes.

The standard drive shaft is sealed by rotary shaft lip type seal.

All pump sizes incorporate helical tooth system. This feature, combined with special gear geometry, results in extremely low noise levels and reduced pressure pulsation.

Working Notes

- The fluids should ensure a certain minimum lubricating properties, should not contain solids and should be chemically compatible.
- Avoid dry operation.
- The pumps may only be operated in the specified direction of rotation, as otherwise the shaft seal will be destroyed.
- In order to prevent excessive overpressure, a safety valve should be provided in the system or on the pump.
- The pressure relief valve attached to the pump may only be used as safety valve for short-term operation.
- A separate pressure relief valve with return line to the reservoir must be foreseen, if a partial discharge flow has to be drained over a prolonged period.

Variants

- Sealing of the drive shaft:
 - Rotary shaft lip-type seal
 - Double rotary shaft lip-type seal (Quench)
 - Mechanical seal
- Outboard bearing to take up input drive-side radial load
- Pressure relief valve for pump and system
- Uniform discharge flow direction with changing direction of rotation by means of flange-mounting valve combination (universal device).

Special Design

To meet your individual requirements on request special constructions are available: for instance mounting flange models, various types of plane bearings, etc. Our Sales engineers will be pleased to advise you.

Accessories

Connecting flange 4-bolt type	Foot mounting flanges for the adaptor flanges below
Mounting angles	Base plates
Pressure relief valves (attachable subsequently)	Couplings
	Adaptor flanges (pump carrier)

Other Types

Pump with electric motor directly connected to each other by an adaptor flange.

Kinematic viscosity ν mm²/s

< 300 300 500 1000 2000 3000 6000 10000 20000 30000

≥ 1500 1250 1000 750 600 500 400 300 200 100

Speed n_{max} 1/min

Note

The above specified minimum and maximum characteristics are NOT applicable for some specific working conditions: maximum working pressure is NOT permissible in conjunction with low speeds and low viscosities. Please contact us whenever such critical ranges are encountered.

Direction of Rotation

The following should be note for direction of rotation:

- when looking at the pump shaft end, the direction of pumping is from left to right if the shaft rotates clockwise.
- when looking at the pump shaft end, the direction of pumping is from right to left if the shaft rotates counterclockwise.

With pressure relief valve

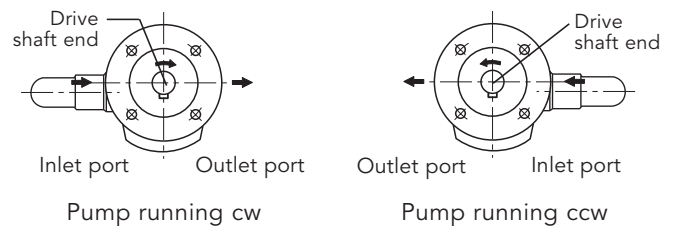

ATEX Design

	KF 3/100...6/730 with lip-type seal	KF 3/100...6/730 with double lip-type seal
In Ex-area max. suitable for category	EX II 2G T4 EX II 2D T135 °C	EX II 2G T4
Perm. working pressure inlet port in bar	-0.4 ... +0.5	-0.4 ... +0.5
Perm. working pressure outlet port in bar	16 ... 25 (depending on nominal size)	16 ... 25 (depending on nominal size)
Perm. viscosity in mm²/s	12 ... 15 000	12 ... 15 000
Max. speed in 1/min (viscosity dependent)	2 000	2 000
Perm. mounting position	Horizontal or shaft end toward bottom	Horizontal quencher up
Perm. media temperatures in °C	-10 ... +80	-10 ... +80
Perm. ambient temperatures in °C	-20 ... +60	-20 ... +60
Comments	Vertical mounting with shaft end up on request. In dust Ex-area, permissible only with non-conductive dusts. Dust-proof capsuling of pump shaft and coupling required.	Not suitable for dust-Ex Execution with quench feed and quencher.

Additional products available on request.

Materials

Type of material and sealing*	Housing / Cover	Gears	Bearing	Shaft end sealing	O-Ring
ODP1/7DP1	EN-GJL-250 (GG 25)	Case hardening steel (1.7139)	P 10	NBR	NBR
ODP2/7DP2				FKM	FKM
OVP1/7VP1	EN-GJS-400-15 (GGG 40)			NBR	NBR
OVP2/7VP2				FKM	FKM

* See nameplate on the pump: KF...

Characteristics

Mounting position	Optional (for exceptions refer to Universal Arrangement)		
Direction of rotation	clockwise or counterclockwise clockwise and counterclockwise		
Mounting	flange- and angle foot type		
Pipe connection	flanged pipe connections, 4-bolt type (straight flange couplings, welding connectors, in addition Intermediate flange heatable), threaded ports		
Working pressures Inlet port	standard	$p_{e \min}$	-0.4 bar (Vacuum) for short time duty e.g. when starting: down to -0.6 bar are permissible, observe the limitation of $p_{e \min}$ for pumps with Universal Arrangement
		$p_{e \max}$	0.5 bar for PTFE rotary shaft lip type seals 1.0 bar for NBR- and FKM rotary shaft lip type seals 10 bar for mechanical seals
	309	$p_{e \min}$	-0.9 bar
		$p_{e \max}$	0.2 bar
	196	$p_{e \min}$	-0.4 bar, Starting condition -0.6 bar
		$p_{e \max}$	25 bar
	197	$p_{e \min}$	-0.4 bar, Starting condition -0.6 bar
		$p_{e \max}$	1 bar
Working pressure Outlet port		P_n	25 bar*
Speed		n_{\min}	200 1/min
		n_{\max}	2000 1/mn The permissible max. speed depends upon the viscosity of the medium operated acc. to the table on page 10
Viscosity		v_{\min}	12 mm ² /s
		v_{\max}	15000 mm ² /s (Viscosities other than within this range on request)
Weight		kg	see dimensional sheets
Fluid temperature		$\vartheta_{m \min}$	-10 °C
		$\vartheta_{m \max}$	90 °C for NBR rotary shaft lip type seals 150 °C for FKM rotary shaft lip type seals and mechanical seals SAVGG 200 °C for PTFE rotary shaft lip type seals 200 °C for mechanical Seals SATGG or ord. code refer to p. 11
Ambient temperature		$\vartheta_{m \min}$	-20 °C
		$\vartheta_{m \max}$	+60 °C
Low temperature			on request
Filter			Filter fineness ≤ 60 µm

* higher pressures only with prior consent from Kracht GmbH

General

The noise optimized pumps of the KF Series are primarily designed for the transport of mediums with an increased share of air, whereby both normal operation and vacuum operation are possible. In applications with no air content in the medium, this type of utilization is not advisable since in such case the noise reduction does not take effect. In these cases, the targeted application of noise reduction elements and also flexible hoses are recommended for achieving noise reduction. Our Sales Engineers are happy to advise you!

The following illustrations show the construction of the KF models described on Page 9. Models 196 and 197 are designed for the transport of air-content transmission oils, therefore for application as a lubricating oil pump in ship gears and stationary gears. Special construction measures prevent the otherwise normal noise increase associated with air-content transmission oils and high degrees of negative pressure. The noise levels do not exceed or only negligibly exceed the measurement valued with non-aircontent oils. A shift in the noise spectrum to higher, unpleasant frequencies also does not occur.

Pumps with the special code 197 are built as mounted pumps or pumps in combination with an electronic motor. The mounted pump (Fig. 1) is equipped with an outboard bearing for the absorption of radial forces like the type that appear when using a floating pinion. The pump in combination with an electronic motor (Fig. 2) has no outboard bearing and must be driven by means of a flexible coupling. Mounted pump and electronic motor are sealed at the shaft end by a rotary shaft seal.

The pumps with the special code 196 are built as mounted pumps both with (Fig. 3) and without an outboard bearing. This model has no seal at the shaft end, making it possible to operate it with pressure on the suction side. The accruing leakage oil is fed off into the gear space. The pumps with the special code 309 (Fig. 4) are designed for deployment in vacuum facilities for the degassing and cleaning of oils. These pumps are built as pumps in combination with an electronic motor and have no outboard bearing for the absorption of external radial forces. At this version, a triple sealing with quench is used as shaft sealing. The middle shaft sealing is mounted for suction operation.

Sound Level

	p = 5 bar	p = 15 bar	p = 25 bar
KF 3/100	70	71	71
KF 3/112	71	72	72
KF 4/125	71	72	73
KF 4/150	72	73	73
KF 4/180	72	73	74
KF 5/200	75	77	77
KF 5/250	76	77	78
KF 5/315	76	76	79
KF 6/400	79	79	80
KF 6/500	81	81	82
KF 6/630	81	81	83
KF 6/730	–	–	–

Sound level measured in dB(A) at 1 m distance
 Sound level measured with drive motor, installation site: Works hall, quiet sound level = 40 dB(A)

Pump assembly on rigid fastening angle,
 Suction and pressure conduits: Hose
 Measured with transmission oil, oil viscosity $\nu = 100 \text{ mm}^2/\text{s}$, oil with app. 4% air content, Speed $n = 1500 \text{ 1/min}$

Construction Noise Optimized Design

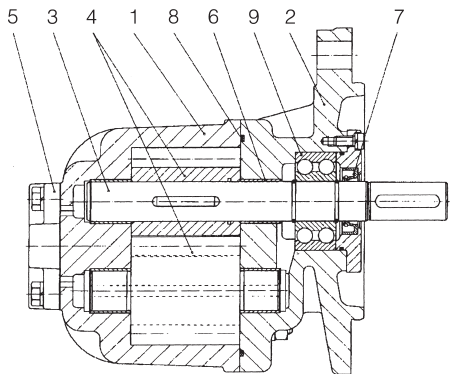

Fig. 1 Pump with outboard bearing, special code 197 (with Shaft end seal)

- 1 Housing
- 2 Flange cover
- 3 Driving shaft
- 4 Gears
- 5 End cover
- 6 Bearing bush
- 7 Shaft end sealing
- 8 O-Ring
- 9 Outboard bearing

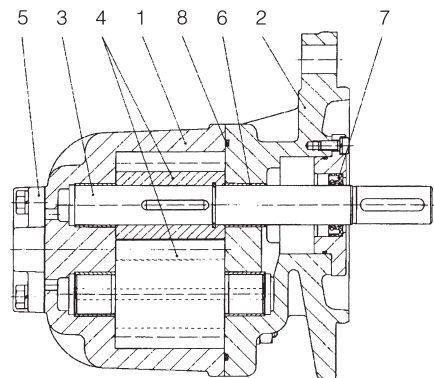

Fig. 2 Pump without outboard bearing, special code 197 (with Shaft end seal)

- 1 Housing
- 2 Flange cover
- 3 Driving shaft
- 4 Gears
- 5 End cover
- 6 Bearing bush
- 7 Shaft end sealing
- 8 O-Ring

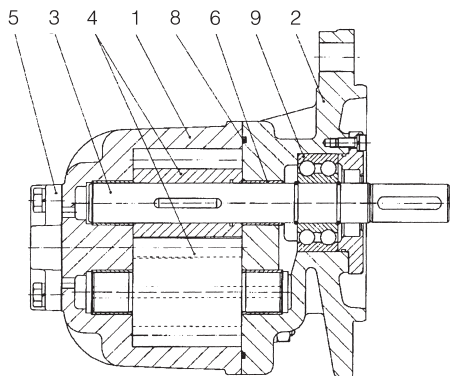

Fig. 3 Pump with outboard bearing, special code 196 (without Shaft end seal)

- 1 Housing
- 2 Flange cover
- 3 Driving shaft
- 4 Gears
- 5 End cover
- 6 Bearing bush
- 7 Shaft end sealing
- 8 O-Ring
- 9 Outboard bearing

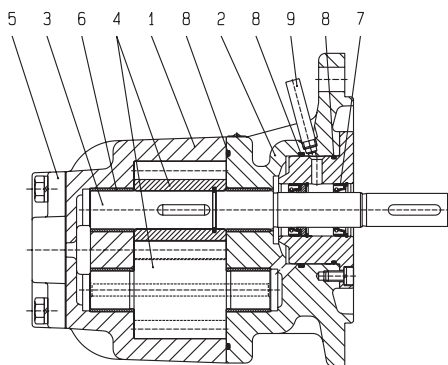

Fig. 4 Pump without outboard bearing, special code 309 (Vacuum design)

- 1 Housing
- 2 Flange cover
- 3 Driving shaft
- 4 Gears
- 5 End cover
- 6 Bearing bush
- 7 Shaft end sealing
- 8 O-Ring
- 9 Connection pipe

Note: Dimensions conformable standard Transfer Gear Pumps KF.

Technical Data

Size	Nominal displacement	Geometrical. displace- volumen V _g cm ³	Working pressure p _b bar	Maximum pressure p _{max} bar	Speed range		Perm. forces (n = 1450 1/min)		Moment of inertia (without coupling x10 ⁻⁴) J kgm ²
					n _{min} 1/min	n _{max} 1/min	F _{radial} N	F _{axial} N	
3 /	100	100.8	25	30	200	2000	1500	200	6.75
	112	112.6	25	25	200	2000	1500	200	7.5
4 /	125	129	25	40	200	2000	1500	200	13.75
	150	153	25	30	200	2000	1500	200	16
5 /	180	184	25	25	200	2000	1500	200	19.25
	200	204	25	30	200	2000	2000	300	27.5
6 /	250	255	20	25	200	2000	2000	300	34.5
	315	321	16	20	200	2000	2000	300	43
6 /	400	405	25	30	200	2000	3000	500	105
	500	505	20	25	200	2000	3000	500	130
6 /	630	629	16	20	200	2000	3000	500	160
	730	730	14	16	200	1500	3000	500	-

Note: Working pressure p_b = permissible continuous pressure
 Maximum pressure p_{max} = only applicable to the operation with mineral oils at speed > 700 1/min and viscosities ν = 30 mm²/s up to 1000 mm²/s
 Permissible forces only applicable to the types fitted with outboard bearing F_{radial} to the middle of the shaft end.

Discharge flow / Input power

Version standard – Speed n = 1450 1/min

Working pressure p _b in bar												Nominal size	Working pressure p _b in bar												
2	4	6	8	10	12	14	16	18	20	22	25		2	4	6	8	10	12	14	16	18	20	22	25	
142	141	140	139	138	137	136	135	134	133	132	130	3/	100	1.2	1.7	2.2	2.7	3.2	3.7	4.2	4.7	5.2	5.7	6.2	6.9
157	156	155	154	153	152	151	150	149	148	147	145		112	1.4	2.0	2.6	3.1	3.7	4.3	4.7	5.3	5.8	6.4	7.0	7.8
180	178	176	175	173	171	169	168	166	164	162	160	4/	125	1.6	2.2	2.8	3.4	4.0	4.6	5.2	5.8	6.4	7.0	7.6	8.5
215	213	212	210	208	206	205	203	201	199	197	195		150	1.9	2.6	3.3	4.0	4.8	5.5	6.2	7.0	7.7	8.4	9.2	10.6
262	260	258	257	255	254	253	251	250	248	247	245	5/	180	2.2	3.0	3.9	4.8	5.7	6.6	7.5	8.4	9.3	10.2	11.0	12.4
285	283	281	279	278	276	274	273	271	269	267	265		200	2.4	3.4	4.4	5.4	6.5	7.5	8.6	9.6	10.7	11.7	12.7	14.2
356	354	351	349	347	344	342	340	338	335	6/	250	3.0	4.3	5.5	6.8	8.1	9.4	10.7	12.0	13.3	14.6				
450	448	447	446	444	443	442	441	315	3.7		5.3	6.9	8.6	10.2	11.7	13.4	15.0								
575	572	569	566	563	560	557	554	551	548	545	540	6/	400	5.8	7.7	9.6	11.6	13.5	15.5	17.5	19.5	21.4	23.3	25.3	28.3
715	711	707	703	699	695	691	688	685	681	500	7.3		9.8	12.3	14.7	17.2	19.6	22.0	24.5	27.0	29.4				
895	891	887	883	878	874	870	865	6/	630	9.3	12.0	15.0	18.0	21.0	24.0	27.0	30.0								
1060	1047	1034	1022	1008	993	978	730		11.0	14.8	18.6	22.4	26.2	30.0	33.7										

Discharge flow Q in l/min

Power input required P in kW

Version noise optimized – Speed n = 1450 1/min

Working pressure p _b in bar												Nominal size	Working pressure p _b in bar												
2	4	6	8	10	12	14	16	18	20	22	25		2	4	6	8	10	12	14	16	18	20	22	25	
138	137	136	135	134	133	132	131	130	129	128	126	3/	100	1.2	1.7	2.2	2.7	3.2	3.7	4.2	4.7	5.2	5.7	6.2	6.9
152	151	150	149	148	147	146	146	145	144	143	141		112	1.4	2.0	2.6	3.1	3.7	4.3	4.7	5.3	5.8	6.4	7.0	7.8
175	173	171	170	168	166	164	163	161	159	157	155	4/	125	1.6	2.2	2.8	3.4	4.0	4.6	5.2	5.8	6.4	7.0	7.6	8.5
209	207	206	204	202	200	199	197	195	193	191	189		150	1.9	2.6	3.3	4.0	4.8	5.5	6.2	7.0	7.7	8.4	9.2	10.6
254	252	250	249	247	246	245	243	243	241	240	238	5/	180	2.2	3.0	3.9	4.8	5.7	6.6	7.5	8.4	9.3	10.2	11.0	12.4
276	275	273	271	270	268	266	265	263	261	259	257		200	2.4	3.4	4.4	5.4	6.5	7.5	8.6	9.6	10.7	11.7	12.7	14.2
345	343	340	339	337	334	332	330	328	325	6/	250	3.0	4.3	5.5	6.8	8.1	9.4	10.7	12.0	13.3	14.6				
437	435	434	433	431	430	429	428	315	3.7		5.3	6.9	8.6	10.2	11.7	13.4	15.0								
558	555	552	549	546	543	540	537	534	532	529	524	6/	400	5.8	7.7	9.6	11.6	13.5	15.5	17.5	19.5	21.4	23.3	25.3	28.3
694	690	686	682	678	674	670	667	664	661	500	7.3		9.8	12.3	14.7	17.2	19.6	22.0	24.5	27.0	29.4				
868	864	860	857	852	848	844	839	6/	630	9.3	12.0	15.0	18.0	21.0	24.0	27.0	30.0								
1028	1016	1003	991	978	963	949	730		11.0	14.8	18.6	22.4	26.2	30.0	33.7										

Discharge flow Q in l/min

Power input required P in kW

The dispersion of discharge flow Q as specified in the above table may be: Q + 2.5 % up to - 5 %.
 At viscosities of ν < 30 mm²/s reduction of the discharge flow Q. At viscosities of ν > 300 mm²/s, the speed must be reduced.
 The drive motor output must be selected 20 % higher than the data for P as specified in the above table.
 For viscosities of ν > 100 mm²/s the power input must be increased. The values count to oils without share of air.

Type Key

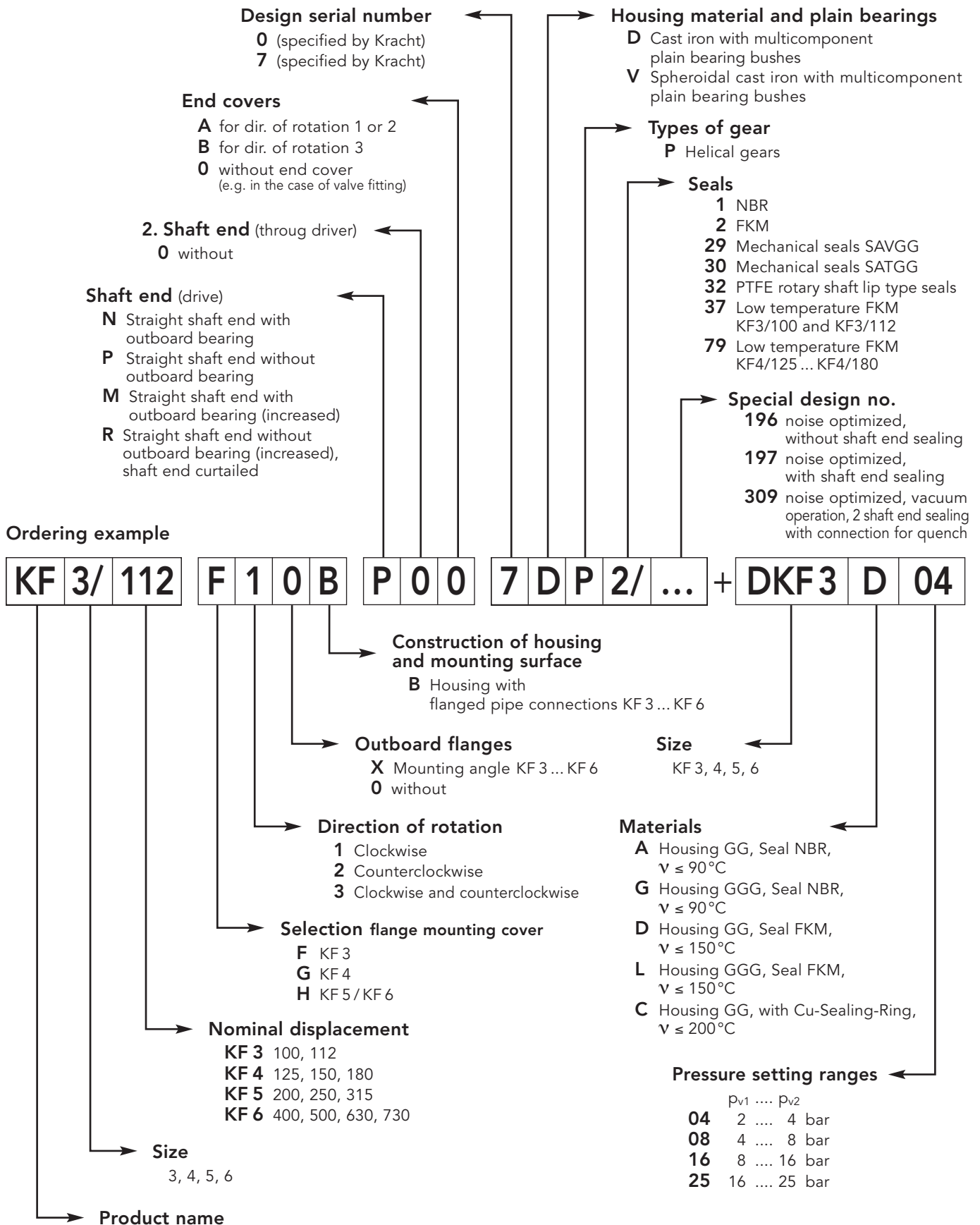

Flange Type Pumps

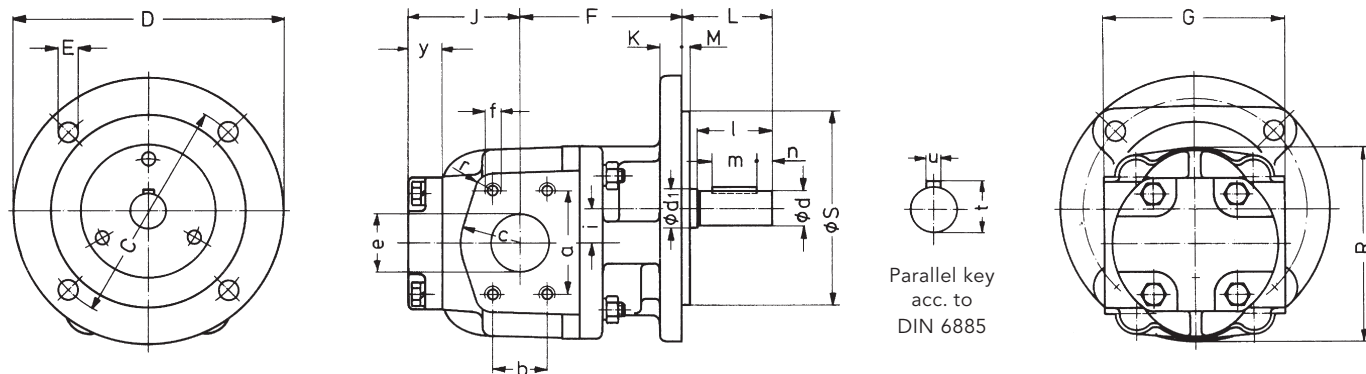

Parallel key
acc. to
DIN 6885

Size	Inlet- and outlet port pipe thread										Shaft end										Weight kg							
	a	b	c	e	f	r	C	D	E	F	G	J	K	L	M	R	S _{h6}	i	y	d ₁		d _{k6}	l	m	n	t	u	
3/ 100 112	69.9	35.7	40	40	M10	16 deep	12	150	180	14	108	120	92	15	60	5	130	130	23	20	25	24	50	30	10	27	8	13.5
125											110		80															
4/ 150 180	77.8	42.9	50	50	M12	18 deep	12	185	220	18	125	130	77	19	60	8	160	150	28.3	20	25	24	50	40	5	27	8	18.5 20 21
200											155		93															
5/ 250 315	88.9	50.8	55	63	M12	20 deep	13	215	250	18	170	150	109	22	70	8	198	180	32	24	30	28	60	40	10	31	8	28 33 33
106.4	61.9	65	75								170		109															
106.4	61.9	65	75								170		109															
400											180		124															
6/ 500 630 730	130.2	77.8	80	100	M16	32 deep	20	215	250	18	200	200	126	25	95	8	244	180	40	24	40	38	80	63	8	41	10	51 55 65 65
											200		159															
											200		159															

*KF3: Dimensions of shaft end line below for shaft P

Ordering code

KF 3/.F ¹/₂/₃ 0B N P 0 A B 7DP ¹/₂/₃₂ V

KF 4/.G ¹/₂/₃ 0B N P 0 A B 7DP ¹/₂/₃₂ V

KF 5/.H ¹/₂/₃ 0B N P 0 A B 0DP ¹/₂/₃₂ V

KF 6/.H ¹/₂/₃ 0B N P 0 A B 7DP ¹/₂/₃₂ V

Flange Type Pumps with Pressure Relief Valve

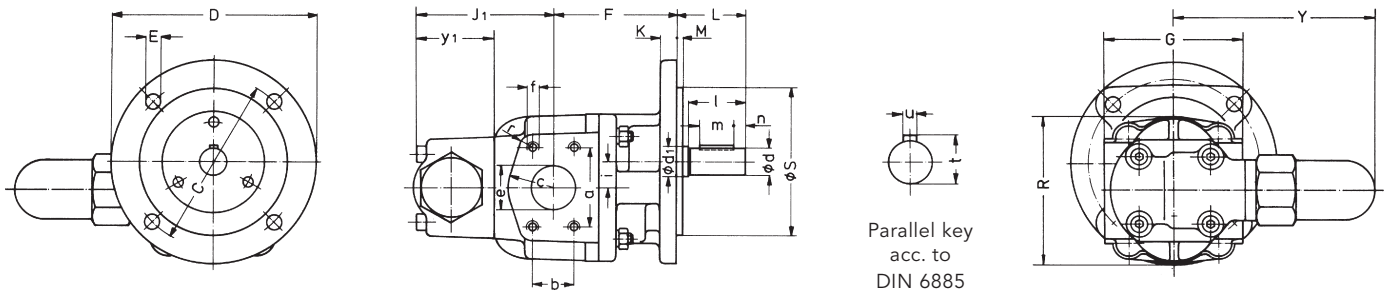

Parallel key
acc. to
DIN 6885

Size	Inlet- and outlet port pipe thread							Shaft end															Weight kg												
	a	b	c	e	f	r	C	D	E	F	G	J ₁	K	L	M	R	Sh ₆	Y	i	y ₁	d ₁	d _{k6}		l	m	n	t	u							
3/ 100 112	69.9	35.7	40	40	M10	16 deep	12	150	180	14	108	120	137	15	60	5	130	130	160	23	65	25	24	50	30	10	27	8	19	50	30	5	21.5	6	15
125													110																						20
4/ 150 180	77.8	42.9	50	50	M12	18 deep	12	185	220	18	125	130	129	19	60	8	160	150	171	28.3	72	25	24	50	40	5	27	8							21.5
200													155																						30
5/ 250 315	88.9	50.8	55	63	M12	20 deep	13	215	250	18	170	150	165	22	70	8	198	180	196	32	80	30	28	60	40	10	31	8							35
400													180																						59
6/ 500 630 730	130.2	77.8	80	100	M16	32 deep	20	215	250	18	200	200	219	25	95	8	244	180	238	40	117	40	38	80	63	8	41	10							63
													200																						73
													252																						73
													200																						73

*KF3: Dimensions of shaft end line below for shaft P

Ordering code

KF 3 / . F ¹/₂ 0B N P 00 ^{7DP}/_V ¹/₂ ³² + DKF 3 ^A/_D ^C/_C ^G/_G .

KF 4 / . G ¹/₂ 0B N P 00 ^{7DP}/_V ¹/₂ ³² + DKF 4 ^A/_D ^C/_C ^G/_G .

KF 5 / . H ¹/₂ 0B N P 00 ^{0DP}/_V ¹/₂ ³² + DKF 5 ^A/_D ^C/_C ^G/_G .

KF 6 / . H ¹/₂ 0B N P 00 ^{7DP}/_V ¹/₂ ³² + DKF 6 ^A/_D ^C/_C ^G/_G .

Flange Type Pumps with Mechanical Seal

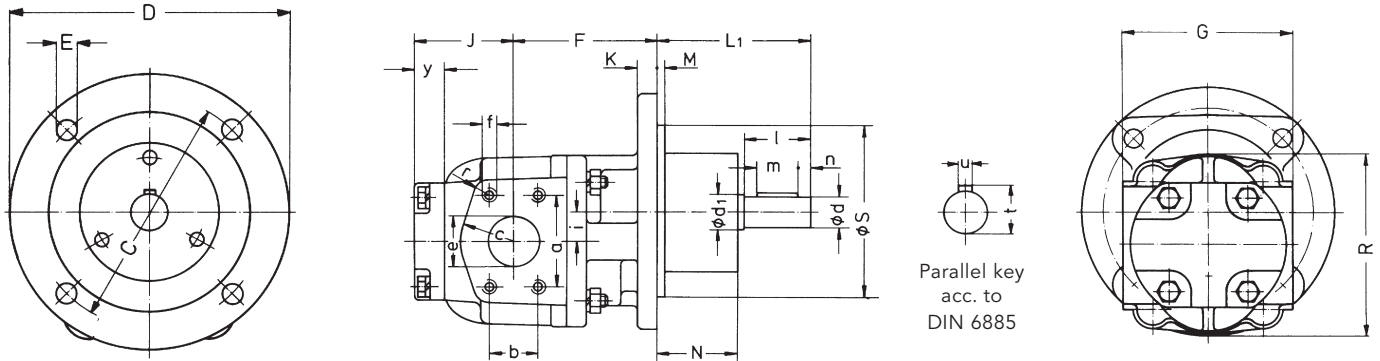

Parallel key
acc. to
DIN 6885

Size	Inlet- and outlet port pipe thread											Shaft end								Weight kg									
	a	b	c	e	f	r	C	D	E	F	G	J	K	L ₁	M	N	R	S _{h6}	i		y	d ₁	d _{k6}	l	m	n	t	u	
3/ 100 112	69.9	35.7	40	40	M10	16 deep	12	150	180	14	108	120	92	15	120	5	69	130	130	23	20	25	24	50	30	10	27	8	15
125										110		80																	20
4/ 150 180	77.8	42.9	50	50	M12	18 deep	12	185	220	18	125	130	77	19	125	8	69	160	150	28.3	20	25	24	50	40	5	27	8	21.5 22.5
200	88.9	50.8	55	63						155		93																	30
5/ 250 315	106.4	61.9	65	75	M12	20 deep	15	215	250	18	170	150	109	22	125	8	61	198	180	32	24	30	28	60	40	10	31	8	35 35
400										180		124																	54
6/ 500 630 730	130.2	77.8	80	100	M16	32 deep	20	215	250	18	200	200	126	25	160	8	72	244	180	40	24	40	38	80	63	8	41	10	58 68 68

Ordering code

KF 3/ . F₂¹ 0B N0A 7DP_V²⁹₃₀

KF 4/ . G₂¹ 0B N0A 7DP_V²⁹₃₀

KF 5/ . H₂¹ 0B N0A 0DP_V²⁹₃₀

KF 6/ . H₂¹ 0B N0A 7DP_V²⁹₃₀

Flange Type Pumps with Mechanical Seal and Pressure Relief Valve

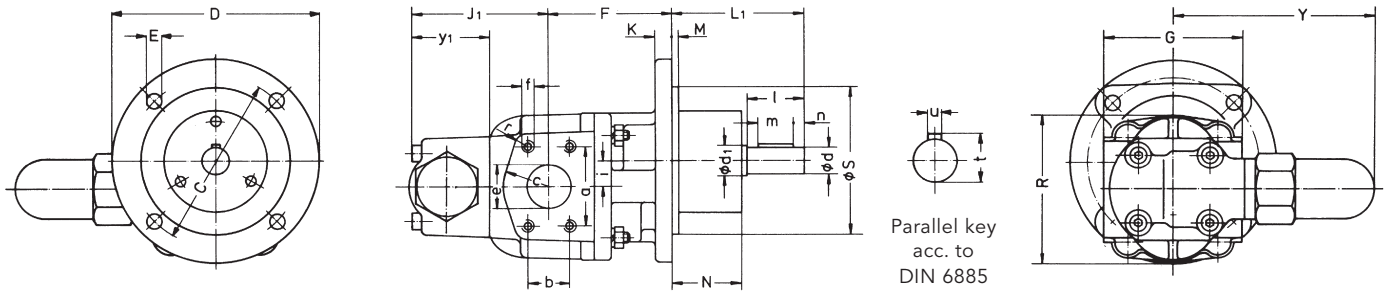

Size	Inlet- and outlet port pipe thread						Shaft end																Weight kg										
	a	b	c	e	f	r	C	D	E	F	G	J ₁	K	L ₁	M	N	R	S _{h6}	i	Y	y ₁	d ₁		dk ₆	l	m	n	t	u				
3/100 112	69.9	35.7	40	40	M10	16 deep	12	150	180	14	108	120	137	15	120	5	69	130	130	23	160	65	25	24	50	30	10	27	8	16.5			
125											110	132																		21.5			
4/150 180	77.8	42.9	50	50	M12	18 deep	12	185	220	18	125	130	129	19	125	8	69	160	150	28.3	171	72	25	24	50	40	5	27	8	23	24		
200	88.9	50.8	55	63			13				155	149																		32			
5/250 315	106.4	61.9	65	75	M12	20 deep	15	215	250	18	170	150	165	22	125	8	61	198	180	32	196	80	30	28	60	40	10	31	8	35	35		
400							15				170	165																		35			
6/500 630 730	130.2	77.8	80	100	M16	32 deep	20	215	250	18	200	200	219	25	160	8	72	244	180	40	238	117	40	38	80	63	8	41	10	62	66	76	76

Ordering code

KF 3/ . F₂¹ 0B N00 ^{7DP}_V²⁹₃₀ + DKF 3 ^D_C_G •

KF 4/ . G₂¹ 0B N00 ^{7DP}_V²⁹₃₀ + DKF 4 ^D_C_G •

KF 5/ . H₂¹ 0B N00 ^{0DP}_V²⁹₃₀ + DKF 5 ^D_C_G •

KF 6/ . H₂¹ 0B N00 ^{7DP}_V²⁹₃₀ + DKF 6 ^D_C_G •

Motor Pump Assemblies KF 3

Pumps with electric motor

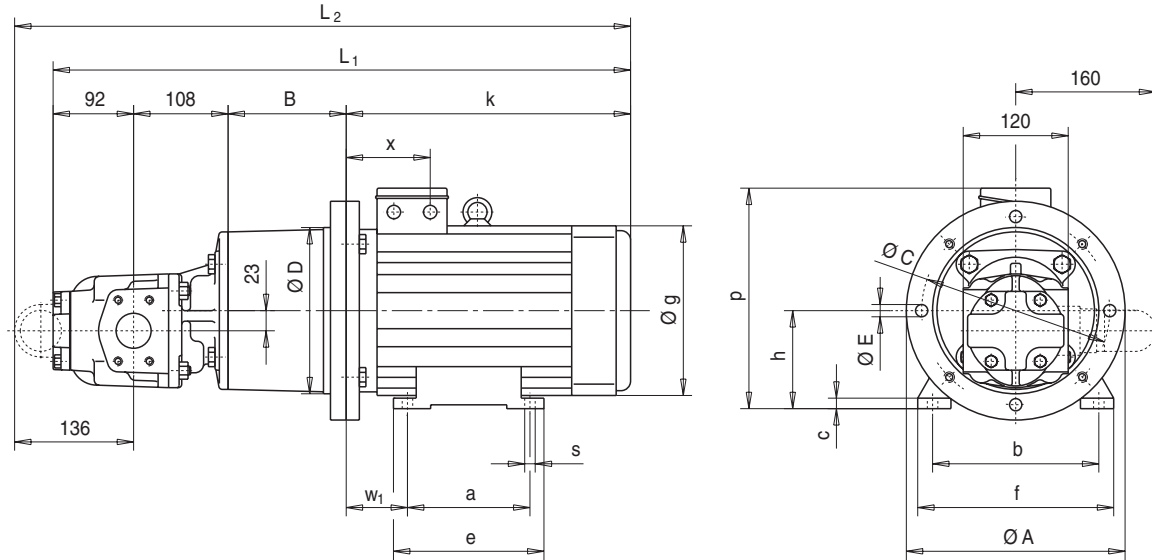

Mounting arrangement: IM B35 (IM V15; IM V36)

Size	Power kW	Speed 1/min	Bell housing	Coupling	Total weight * kg	L ₁	L ₂
100 L4A	2.2	1420	Z3/250/135	RA28-Z35/19-Z35/28	37	633	677
100 L4B	3.0	1430			40	633	677
112 M4B	4.0	1440			47	670	714
132 S4C	5.5	1450	Z3/300/180	RA38-Z45/19-Z45/38	58	748	792
132 M4B	7.5	1450			79	779	823
160 M4B	11.0	1450	Z3/350/204	RA38/45-Z45/19-Z45/42	94	870	914
160 L4A	15.0	1450			108		
180 M4B	18.5	1450	Z3/350/204	RA42/55-Z50/19-Z50/48	138	923	967
180 L4B	22.0	1455			146		

* Additional weight for units with pressure relief valve 1.5 kg

Size	Ø A	B	Ø C	Ø D	Ø E	a	b	c	e	f	g	h	k	p	s	w1	x
100 112	250	135	215	190	14	140	160 190	12	172	192 224	213 234	100 112	298 335	232 252	12	63 70	96 106
132 S 132 M	300	180	265	234	14	140 178	216	12	187 218	264 266	265 298	132	358 399	283 303	12	89	112 118
160 M 160 L	350	204	300	260	17	210 254	254	18	306	306	323	160	466	341	15	108	114
180 M 180 L	350	204	300	260	17	241 279	279	22	343	344	370	180	519	387	15	121	136

The values specified in the table above relate after DIN 42 G 73 / G 77 (Motors from other manufactures are available on request)

When ordering a flange type pump with electric motor please specify the rated voltage, the frequency, the speed and the enclosure requested

Motor Pump Assemblies KF 4

Pumps with electric motor

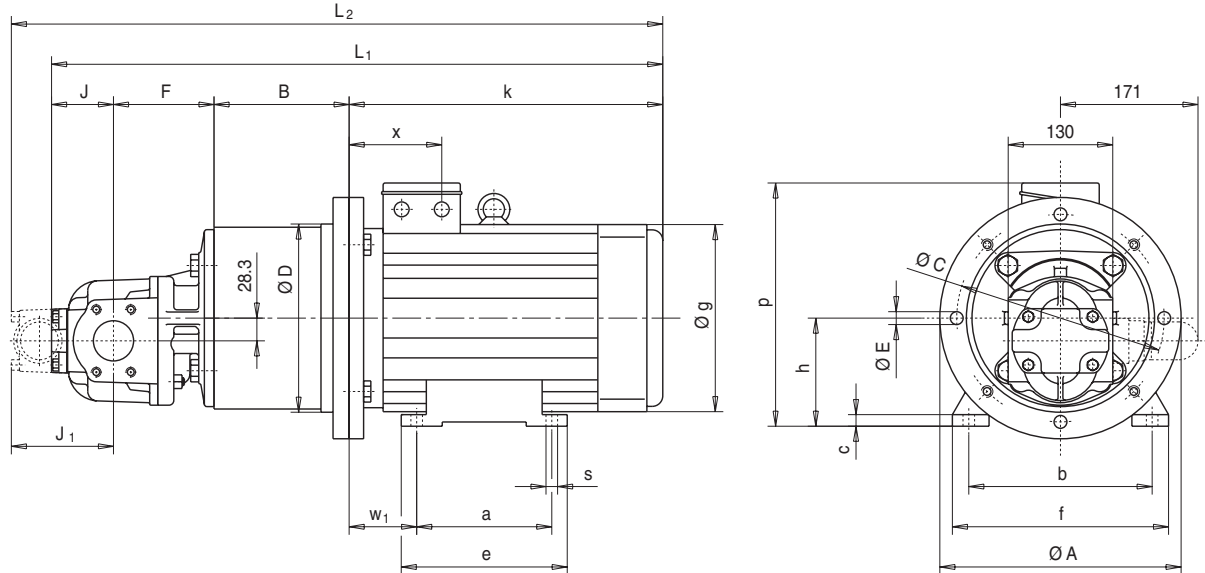

Mounting arrangement: IM B35 (IM V15; IM V36)

Motor size	Power kW	Speed 1/min	Bell housing	Coupling	Total weight ** kg			L ₁			L ₂		
					4/125	4/150	4/180	4/125	4/150	4/180	4/125	4/150	4/180
100 L4A	2.2	1420	Z4/250/138*	RA24/28-Z30/24-Z30/28	44	46	47	623	635	645	675	687	697
100 L4B	3.0	1430			47	49	50	623	635	645	675	687	697
112 M4B	4.0	1440			54	56	57	660	672	682	712	724	734
132 S4C	5.5	1450	Z4/300/168	RA28/38-Z35/24-Z35/38	61	63	64	738	750	760	790	802	812
132 M4B	7.5	1450			82	84	85	769	781	791	821	833	843
160 M4B	11.0	1450	Z4/350/204	RA38/45-Z45/24-Z45/42	99	101	102	860	872	882	912	924	934
160 L4A	15.0	1450			113	115	116						
180 M4B	18.5	1450	Z4/350/204	RA42/55-Z50/24-Z50/48	142	144	145	913	925	935	965	977	987
180 L4B	22.0	1455			150	152	153						

Those adaptor flanges marked by * are not suitable for installations into reservoirs the pump flange dia. is larger than than the centering dia. of the adaptor flange.

** Additional weight for units with pressure relief valve 1.5 kg

Motor size	Ø A	B	Ø C	Ø D	Ø E	a	b	c	e	f	g	h	k	p	s	w1	x
100 112	250	135	215	190	14	140	160 190	12	172	192 224	213 234	100 112	298 335	232 252	12	63 70	96 106
132 S 132 M	300	180	265	234	13	140 178	216	12	187 218	264 266	265 298	132	358 399	283 303	12	89	112 118
160 M 160 L	350	204	300	260	17	210 254	254	18	306	306	323	160	466	341	15	108	114
180 M 180 L	350	204	300	260	17	241 279	279	22	343	344	370	180	519	387	15	121	136

The values specified in the table above relate after DIN 42 G 73 / G 77 (Motors from other manufactures are available on request)

Pump dimensions

	KF4/125	KF4/150	KF4/180
F	110	125	135
J	80	77	77
J ₁	132	129	129

When ordering a flange type pump with electric motor please specify the rated voltage, the frequency, the speed and the enclose requested

Motor Pump Assemblies KF 5

Pumps with electric motor

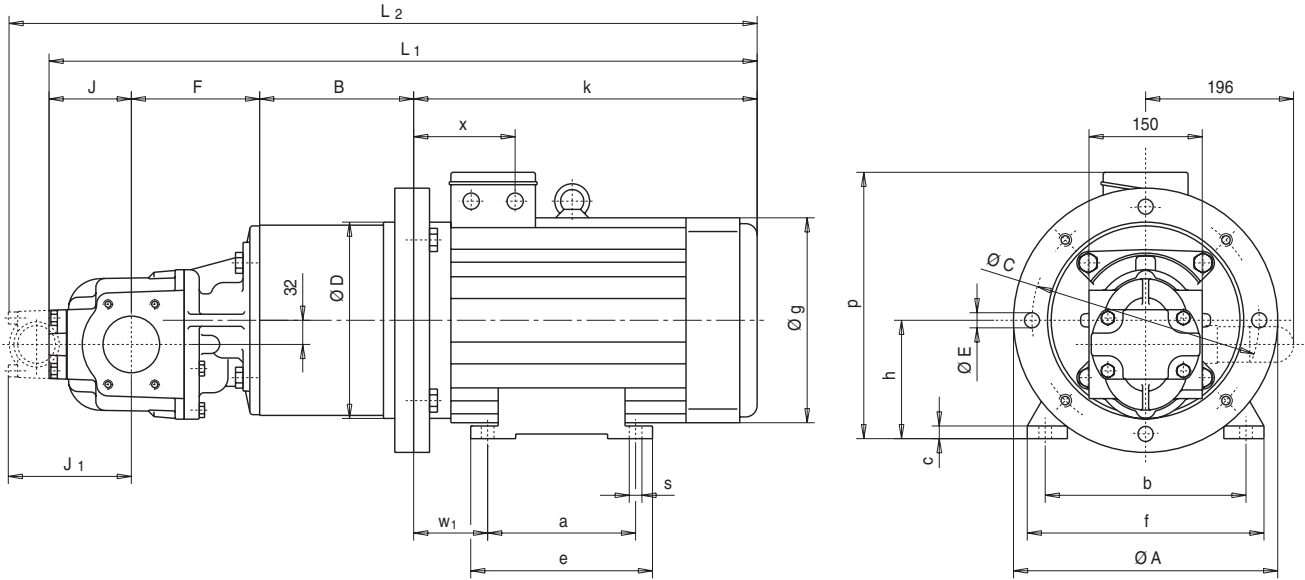

Mounting arrangement: IM B35 (IM V15; IM V36)

Motor size	Power kW	Speed 1/min	Bell housing	Coupling	Total weight ** kg			L ₁			L ₂		
					5/200	5/250	5/315	5/200	5/250	5/315	5/200	5/250	5/315
132 S4C 132 M4B	5.5 7.5	1450 1450	Z5/300/195*	RA42-Z50/28-Z50/38	73 94	78 99	78 99	811 842	842 873	842 873	867 898	898 929	898 929
160 M4B 160 L4A	11.0 15.0	1450 1450	Z5/350/204	RA38/45-Z45/28-Z45/42	109 123	114 128	114 128	918	949	949	974	1005	1005
180 M4B 180 L4B	18.5 22.0	1450 1455	Z5/350/204	RA42/55-Z50/28-Z50/48	153 161	158 166	158 166	971	1002	1002	1027	1058	1058

Those adaptor flanges marked by * are not suitable for installations into reservoirs the pump flange dia. is larger than than the centering dia. of the adaptor flange.

** Additional weight for units with pressure relief valve 2 kg

Motor size	Ø A	B	Ø C	Ø D	Ø E	a	b	c	e	f	g	h	k	p	s	w1	x
132 S 132 M	300	195	265	234	14	140 178	216	12	187 218	264 266	265 298	132	358 399	283 303	12	89	112 118
160 M 160 L	350	204	300	260	17	210 254	254	18	306	306	323	160	466	341	15	108	114
180 M 180 L	350	204	300	260	17	241 279	279	22	343	344	370	180	519	387	15	121	136

The values specified in the table above relate after DIN 42 G 73 / G 77 (Motors from other manufactures are available on request)

Pump dimensions

	KF5/200	KF5/250	KF5/315
F	155	170	170
J	93	109	109
J ₁	149	165	165

When ordering a flange type pump with electric motor please specify the rated voltage, the frequency, the speed and the enclosure requested

Motor Pump Assemblies KF 6

Pumps with electric motor

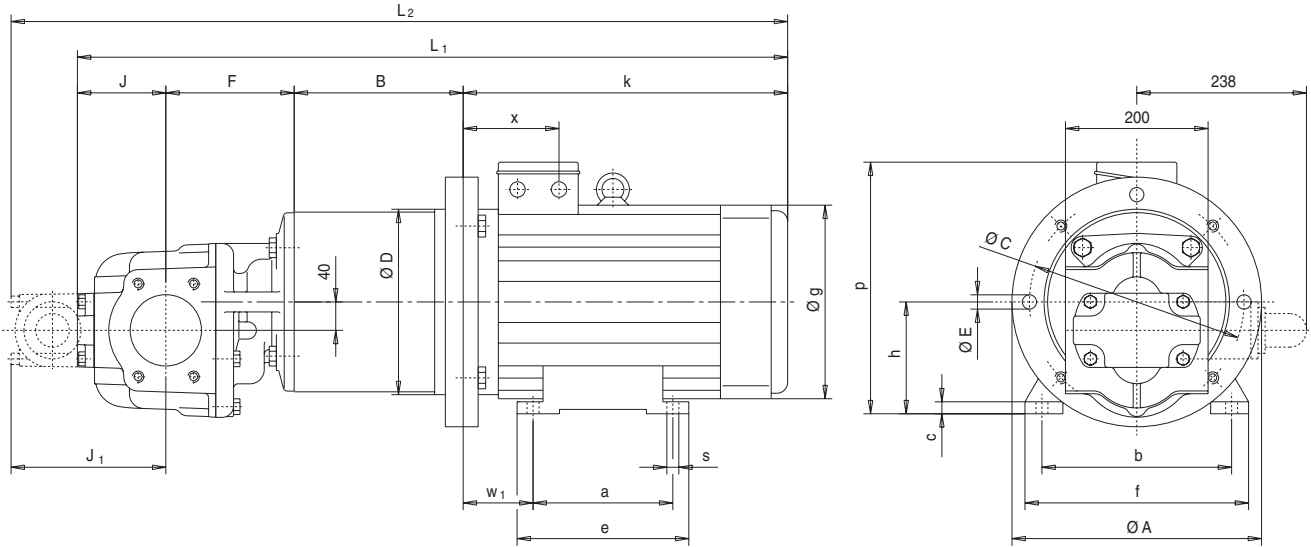

Mounting arrangement: IM B35 (IM V15; IM V36)

Motor size	Power kW	Speed 1/min	Bell housing	Coupling	Total weight *				L ₁				L ₂			
					kg				6/400	6/500	6/630	6/730	6/400	6/500	6/630	6/730
160 M4B 160 L4A	11.0 15.0	1450 1450	Z6/350/237	RA38/45- Z45/38-Z45/42	134 148	138 152	148 162	148 162	1007	1029	1062	1062	1100	1122	1155	1155
180 M4B 180 L4B	18.5 22.0	1450 1455	Z6/350/237	RA42/55- Z50/38-Z50/48	177 185	181 189	191 199	191 199	1060	1082	1115	1115	1153	1175	1208	1208
200 L4C	30.0	1450	Z6/400/228	RA42/55- Z50/38-Z50/55	235	239	249	249	1087	1109	1142	1142	1180	1202	1235	1235
225 S4A 225 M4C	37.0 45.0	1460 1460	Z6/450/262	RA48/60- Z56/38-Z56/60	285 322	289 326	299 336	299 336	1192	1214	1247	1247	1285	1307	1340	1340
250 M4C	55.0	1465	Z6/550/275	RG55/70- Z65/38-Z65/65	352	356	366	366	1223	1245	1278	1278	1316	1338	1371	1371

* Additional weight for units with pressure relief valve 8 kg

Motor size	Ø A	B	Ø C	Ø D	Ø E	a	b	c	e	f	g	h	k	p	s	w1	x
160 M 160 L	350	237	300	260	17	210 254	254	18	306	306	323	160	466	341	15	108	114
180 M 180 L	350	237	300	260	17	241 279	279	22	343	344	370	180	519	387	15	121	136
200 L	400	228	350	300	17	306	318	24	365	388	415	200	555	435	19	133	175
225 S 225 M	450	262	400	350	17	286 311	356	26	383	442	456	225	626	485	19	149	189
250 M	550	275	500	450	17	349	406	27	415	495	456	250	644	510	24	168	207

The values specified in the table above relate after DIN 42 G 73 / G 77 (Motors from other manufactures are available on request)

Pump dimensions

	KF6/400	KF6/500	KF6/630	KF6/730
F	180	200	200	200
J	124	126	159	159
J ₁	217	219	252	252

When ordering a flange type pump with electric motor please specify the rated voltage, the frequency, the speed and the enclose requested

Flange-Type Pumps with Universal Arrangement

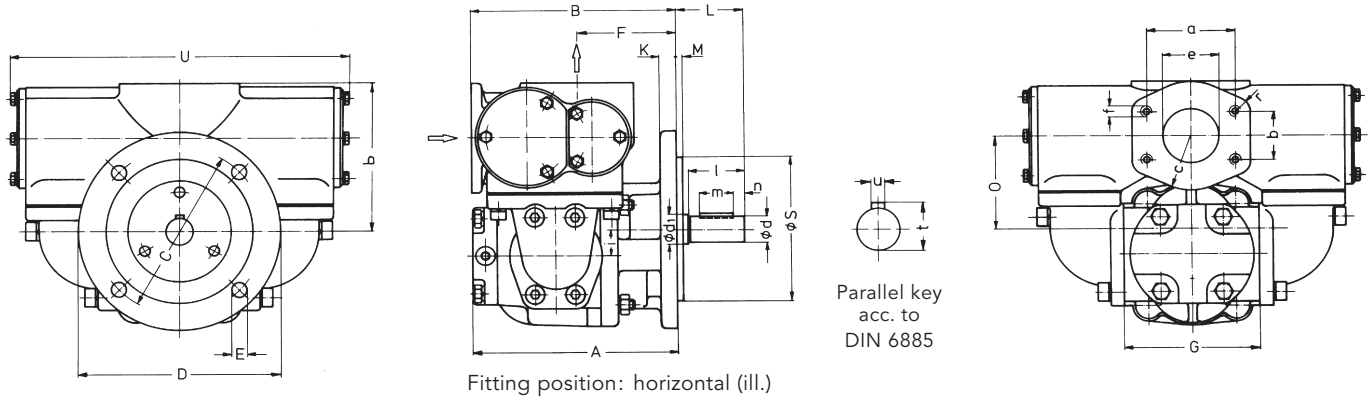

Size	Inlet- and outlet port pipe thread							Shaft end											Weight kg	Permissible manometric vacuum at the pump inlet port P _e in bar															
	a	b	c	e	f	r	A	B	C	D	E	F	G	K	L	M	O	P			S _{h6}	U	i	d ₁	d _{k6}	l	m	n	t	u					
3/100 112	77.8	42.9	50	50	M12	12	200	183	150	180	14	93	120	15	60	5	90	140	130	298	23	25	24	50	30	10	27	8	34	0.36 0.35					
125 4/150 180	77.8	42.9	50	50	M12	12	190	185				95																		39	0.34				
							202	200	185	220	18	110	130	19	60	8	96	146	150	298	28.3	25	24	50	40	5	27	8	40					40	0.33
							212	210				120																							41
200 5/250 315	106.4	61.9	65	75	M12	15	248	252				122																		80	0.38				
							279	267	215	250	18	137	150	22	70	8	129	199	180	442	32	30	28	60	40	10	31	8	40				85	0.37	
							279	267				137																						85	0.36
400 6/500 630 730	130.2	77.8	80	100	M16	20	304	277				147																		103	0.37				
							326	297	215	250	18	167	200	25	95	8	171	241	180	442	40	40	38	80	63	8	41	10	40				107	0.36	
							359	297				167																							117
	106.4	61.9	65	75	M12	15	359	297				167																		117	—				

Ordering code

KF 3/ . F3 0B N0B $\frac{7DP}{V}$. + KF4U 04

KF 4/ . G3 0B N0B $\frac{7DP}{V}$. + KF4U 05

KF 5/200 H3 0B N0B $\frac{0DP}{V}$. + KF5U 06

KF 5/250 H3 0B N0B $\frac{0DP}{V}$. + KF5U 07

KF 5/315 H3 0B N0B $\frac{0DP}{V}$. + KF5U 07

KF 6/ . H3 0B N0B $\frac{7DP}{V}$. + KF6U 08

Accessories connecting flange

Welding connector KF 3, KF 4

Ordering example

2 Pieces Welding Connector KF 4

complete welding connector with gasket and screws for the size KF 4

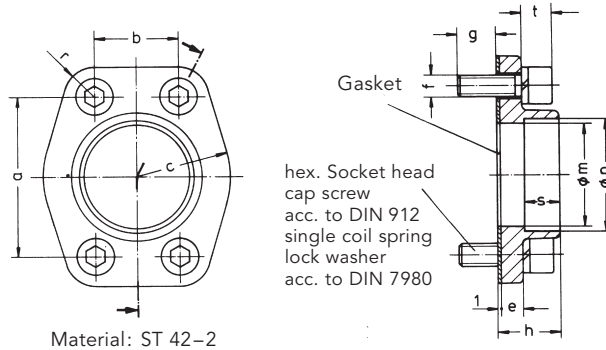

Welding connector KF 5, KF 6

Ordering example

2 Pieces Welding Connector KF 5

complete welding connector with gasket and screws for the size KF 5 / 250

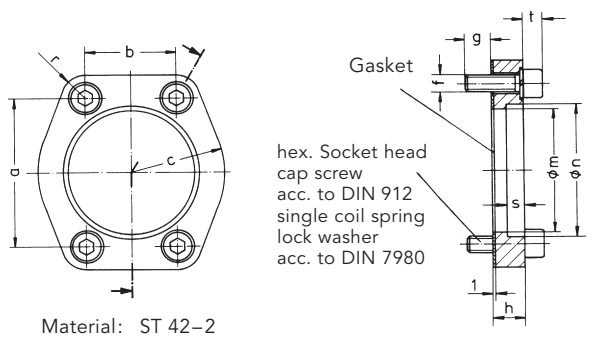

Size	Nom. displacement	a	b	c	e	f	g	h	m	n	r	s	t	Screws DIN 912-8.8	Nom-size	Pipe external Ø	Weight kg
KF 3		69.9	35.7	40	9	M10	13	26	45	49	13	15	-	M10x25	40	48.3	0.44
KF 4		77.8	42.9	50	9	M12	17	26	57	61	13	15	-	M12x30	50	60.3	0.63
KF 5 / 200		88.9	50.8	55	-	M12	16	18	68	77	15	12	12	M12x35	65	76.1	0.86
KF 5 / 250 / 315		106.4	61.9	65	-	M12	16	18	82	90	15	12	12	M12x35	80	88.9	1.2
KF 6		130.2	77.8	80	-	M16	24	24	107	115.3	20	15	20	M16x50	100	114.3	2.5

Welding connector KF 3, KF 4

Ordering example

2 Pieces Threaded Connector KF 4

complete threaded connector with gasket and screws for the size KF 4

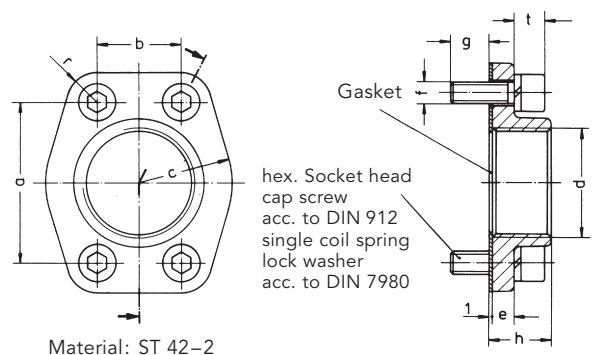

Size	a	b	c	d	e	f	g	h	r	t	Screws DIN 912-8.8	Weight kg
KF3	69.9	35.7	40	G 1½	9	M10	13	26	13	-	M10x25	0.44
KF4	77.8	42.9	50	G 2	9	M12	17	26	13	-	M12x30	0.63

Flange Type Pumps with Mounting Angle

Materials

Housing: Cast iron with lamellar graphite acc. to DIN 1691

Shafts and gears: Case hardening steel acc. to DIN 17210 surface hardened and grinded

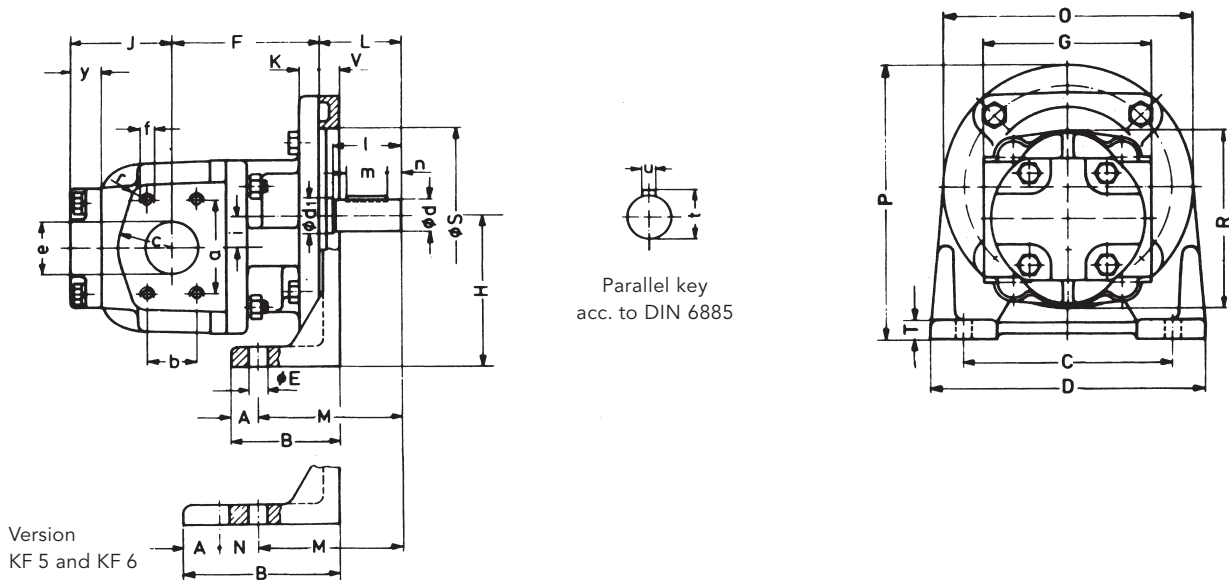

Mounting angle dimensions

	A	B	C	D	E	H	M	N	O	P	T	V
KF 3	20	80	150	180	14	112	105	–	180	202	15	15
KF 4	20	95	170	200	14	132	115	–	220	242	15	20
KF 5	40	220	180	220	14	160	190	40	250	285	18	20
KF 6	45	285	250	300	18	200	240	70	250	325	22	25

Size	Inlet- and outlet port flange							Shaft end										Weight kg							
	a	b	c	e	f	r	F	G	J	K	L	R	S _{H7}	i	Y	d ₁	d _{k6}		l	m	n	t	u		
3/100 112	69.9	35.7	40	40	M10	16 deep	12	108	120	92	15	60	130	130	23	20	25 *20	24 19	50	30	10 5	27 21.5	8 6	14	
125 4/150 180	77.8	42.9	50	50	M12	18 deep	12	110 125 135		80 77 77		19	60	160	150	28.3	20	25	24	50	40	5	27	8	20 22 23
200 5/250 315	88.9 106.4 106.4	50.8 61.9 61.9	50 65 65	63 75 75	M12	20 deep	13 15 15	155 170 170		93 93 109		22	70	198	180	32	24	30	28	60	40	10	31	8	31.5 36.5 36.5
400 6/500 630 730	130.2	77.8	80	100	M16	32 deep	20	180 200 200 200		124 126 159 159		25	95	244	180	40	24	40	38	80	63	8	41	10	59 63 73 73

* KF 3: Dimensions of shaft end line below for shaft P

Characteristic Curves

Charts for KF 3/100 ... KF 3/112

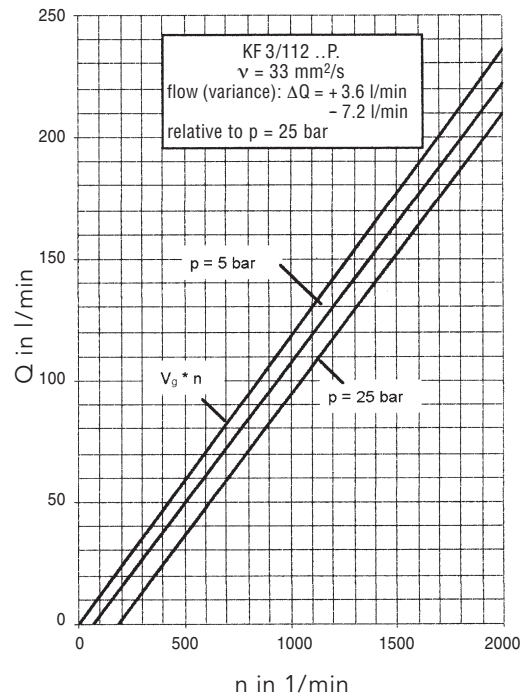
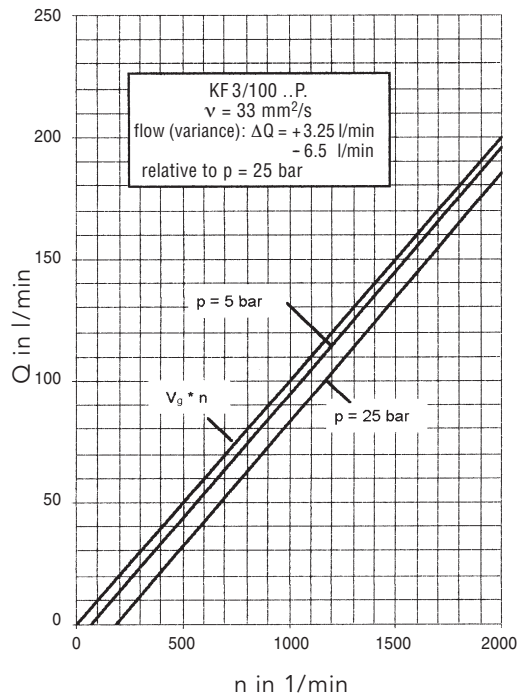

Charts for KF 4/125 ... KF 4/180

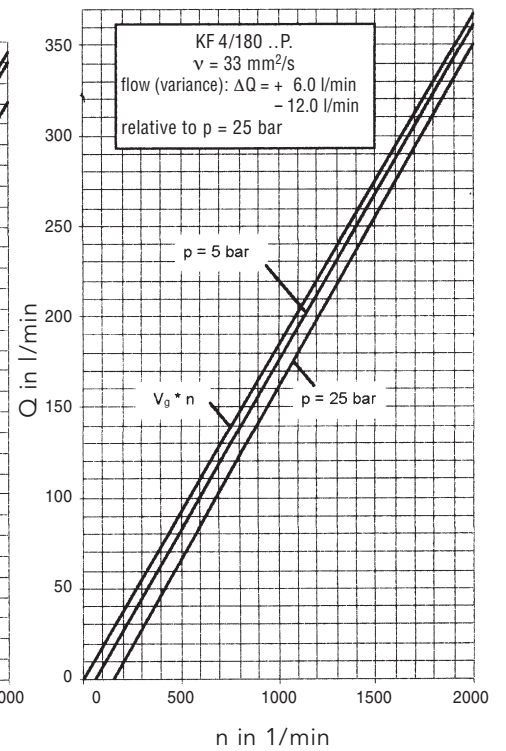
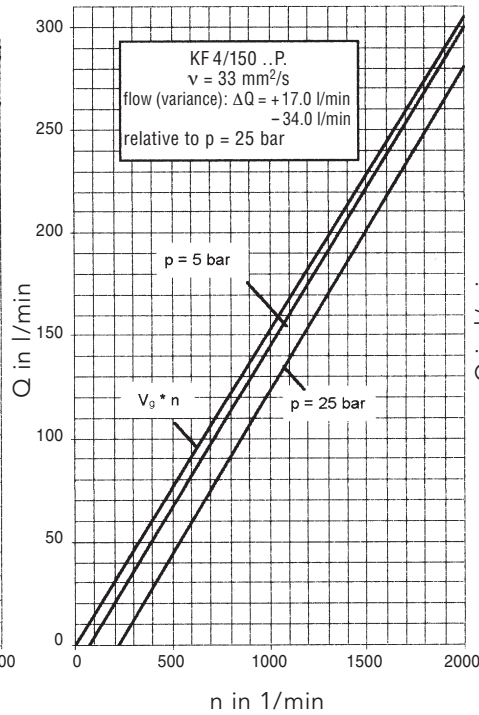
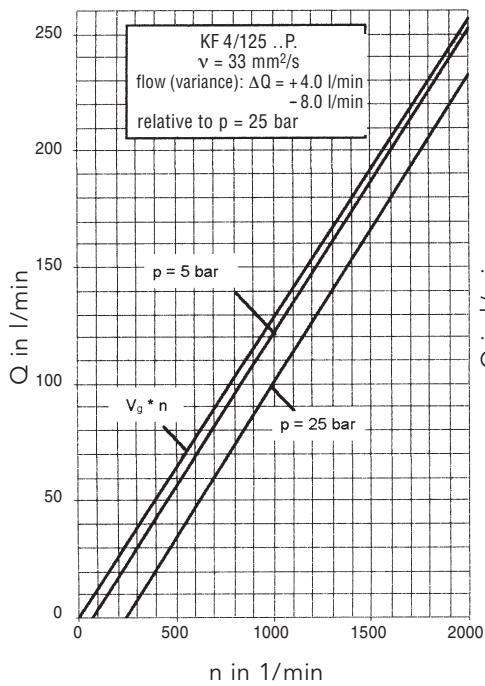

Characteristic Curves

Charts for KF 5/200 ... KF 5/315

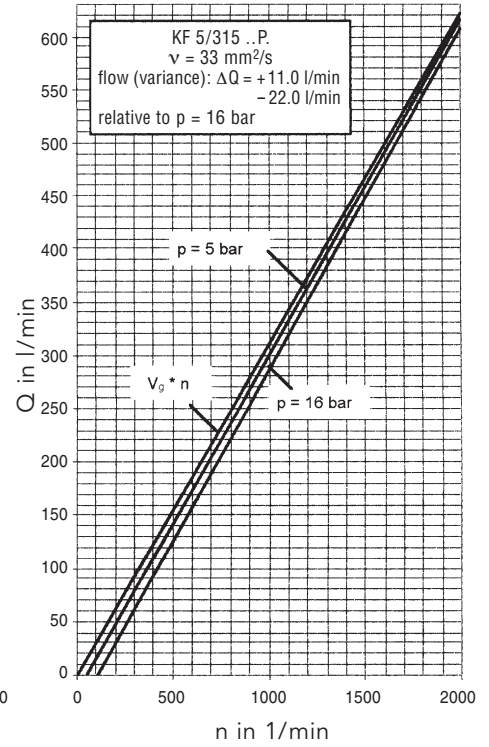
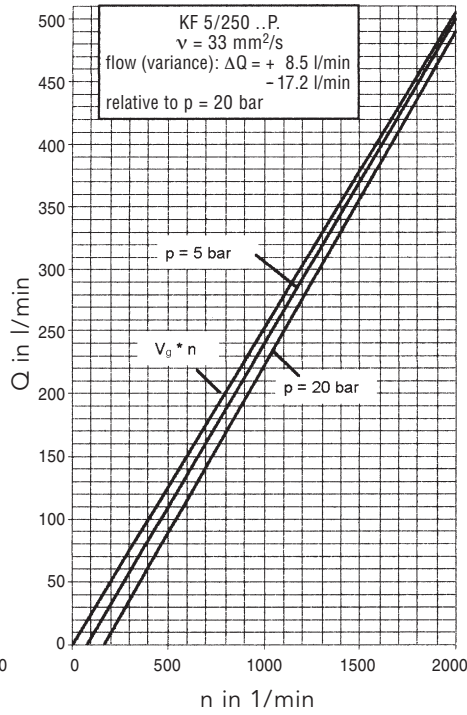
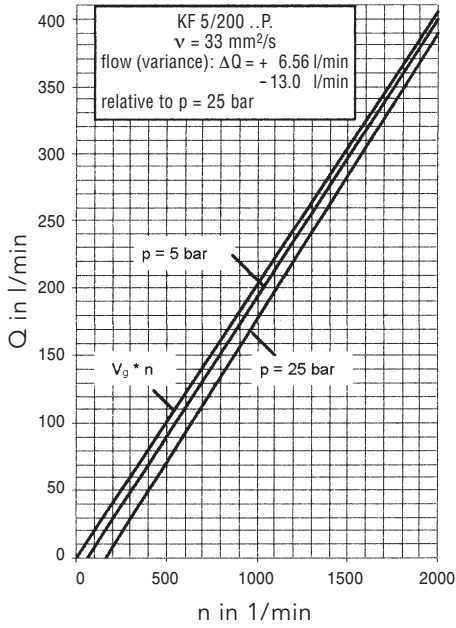

Charts for KF 6/400 ... KF 6/630

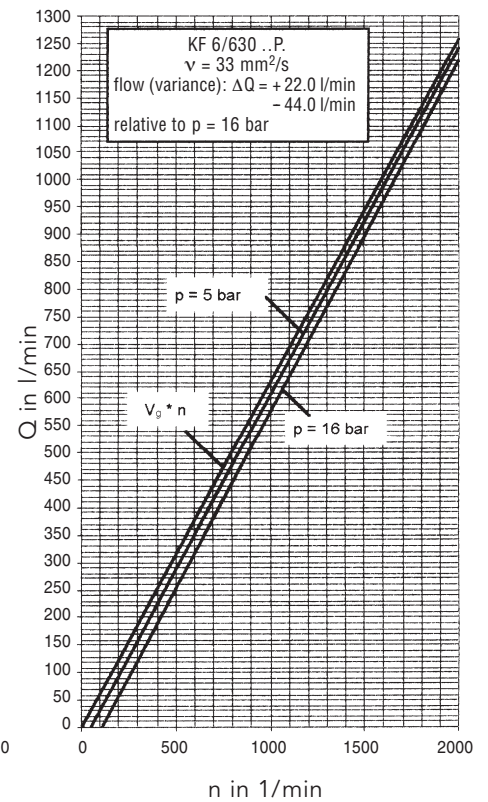
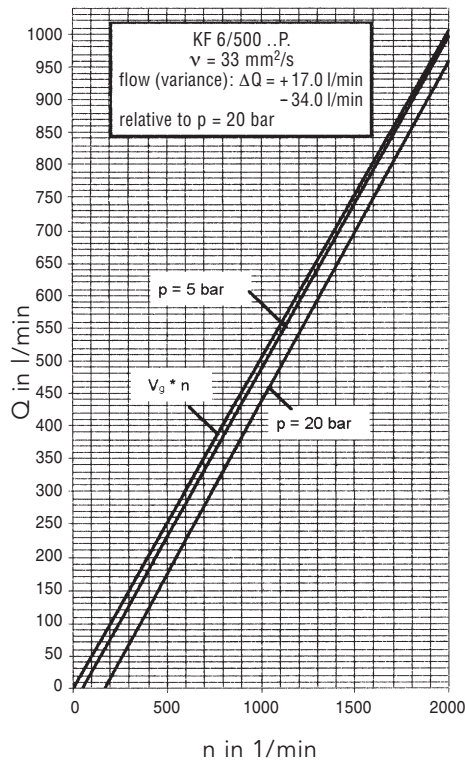
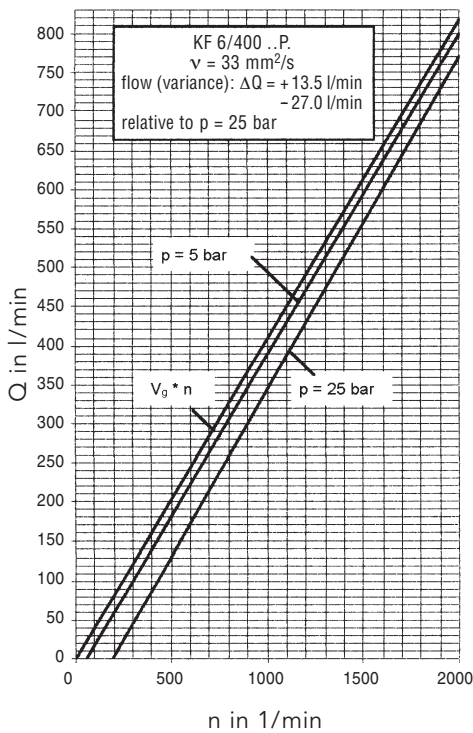

Characteristic Curves

Chart for KF 6/730

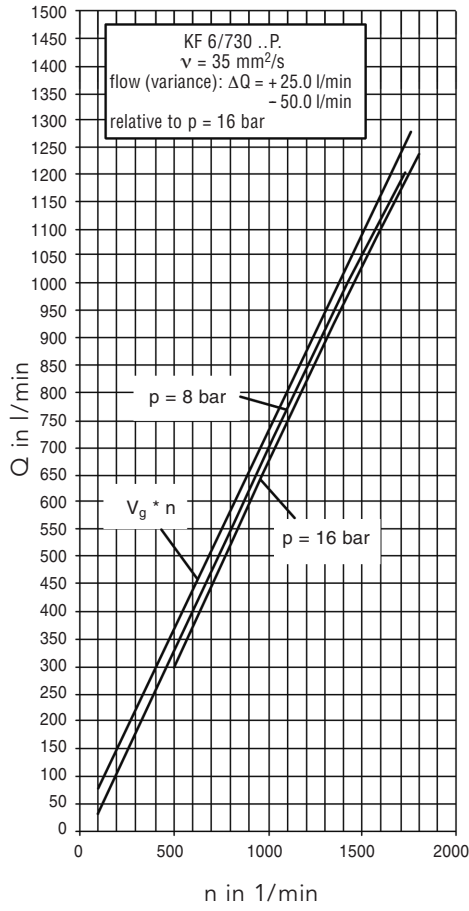

Product Portfolio

Transfer Pumps

Transfer pumps for lubricating oil supply equipment, low pressure filling and feed systems, dosing and mixing systems.

Mobile Hydraulics

Single and multistage high pressure gear pumps, hydraulic motors and valves for construction machinery, vehicle-mounted machines.

Flow Measurement

Gear and turbine flow meters and electronics for volume and flow metering technology in hydraulics, processing and laquering technology.

Industrial Hydraulics / Test Bench Construction

Cetop directional control and proportional valves, hydraulic cylinders, pressure, quantity and stop valves for pipe and slab construction, hydraulic accessories for industrial hydraulics (mobile and stationary use).

Technology Test benches / Fluid Test benches.



KF3/100... KF6/730/GB/05.11

VERDER NV

Kontichsesteenweg 17
B-2630 Aartselaar
Belgium

TEL +32 3 877 11 12
FAX +32 3 877 05 75
MAIL info@verder.be
WEB www.verder.be

AT Wien **BE** Aartselaar **BG** Sofia **CH** Basel **CN** Shanghai **CZ** Praha
DE Haan **DK** Rødovre **FR** Eragny s/Oise **GB** Castleford **HU** Budapest
IN Pune **NL** Groningen/Vleuten **PL** Katowice **RO** Bucuresti/Sibiu
SK Bratislava **TH** Bangkok **US** Macon (GA) **ZA** Northriding