

# Verderflex VF15

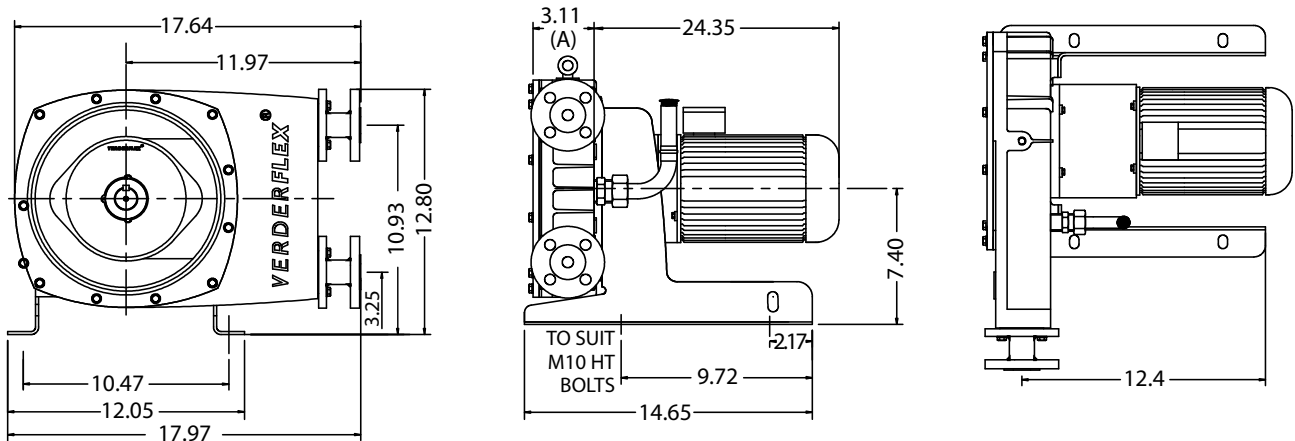

VERDERFLEX®

Description	Material	Paint Detail
Pump Housing	Aluminium (LM25) Option: Cast Iron (GG25)	Green Powder Coated
Front Cover	Clear Polycarbonate	
Rotor	Aluminium (BS.1490:1988 LM25M) Option: Cast Iron (ASTM A 536)	
Port Flange	304 Stainless Steel Universal slotted design fits with 15 mm 5/8" DIN PN16, ANSI 150# & JIS10K Options: Hose Tail Inserts and 316 Hygienic Flanges available on request to special order	
Inserts	Stainless Steel (316L) Options: Polypropylene, P.V.D.F. Inserts and 316 Stainless Steel Hose Tail	
Mounting Frame	Carbon Steel	Powder Coated
Lubricant	Verderlube - Glycerine based compound Verdersil - Silicone oil	
Hose	Natural Rubber (NR) Options: Nitrile Buna Rubber (NBR) Ethylene Propylene Diene Monomer (EPDM) and Hypalon® (CSM)	
Typical Pump Unit Weight	Aluminium Unit: 75 - 90 lbs Cast Iron Unit: 101 - 115 lbs	



All dimensions are in inches.  
All dimensions and weights are for guidance only.



# Verderflex VF15

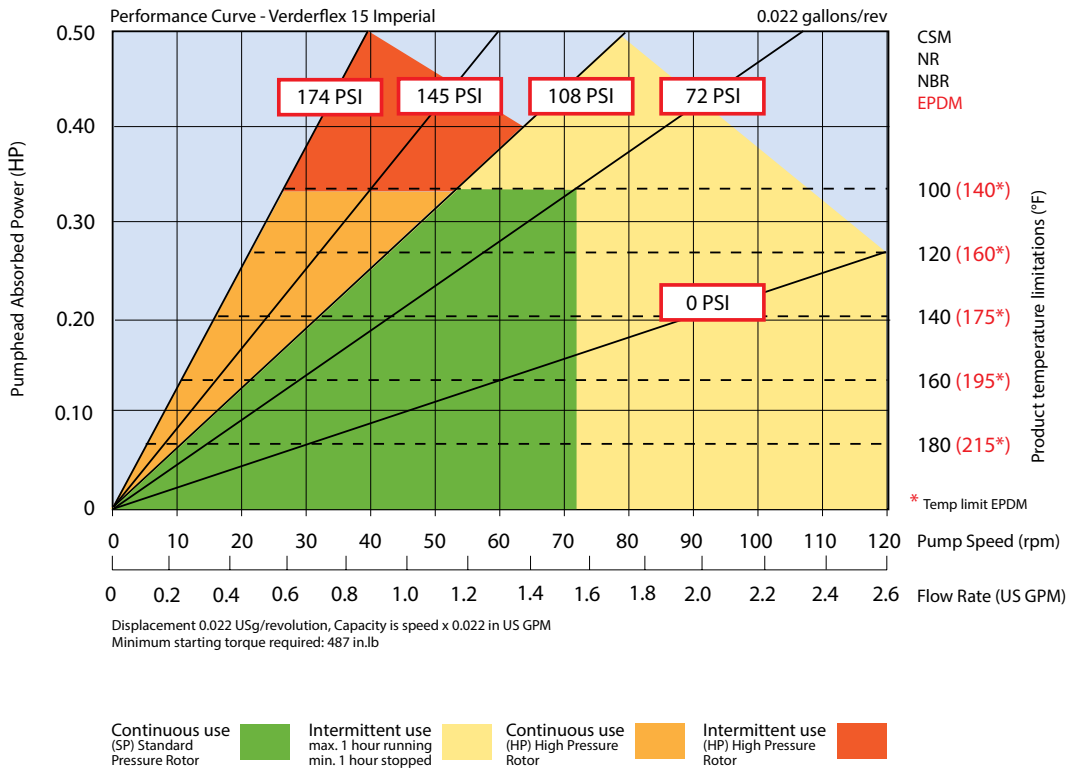

Flows are typical and were measured with water at 68°F with no suction lift or discharge pressure. Actual flows will vary according to suction conditions, discharge pressure and normal component production tolerances.

Find your local supplier  
at [www.verderflex.com](http://www.verderflex.com)

For construction installation and floor mounting drawings  
please contact your local authorised Verderflex® distributor.

**VERDER**  
passion for pumps