

Verderflex

Dura 25

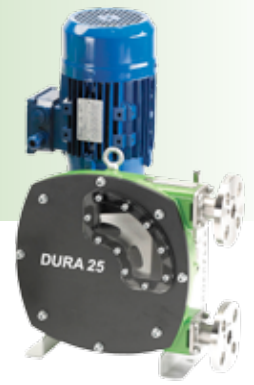

VERDERFLEX®

Description

The Verderflex Dura 25 is a compact, high pressure hose pump with superior secondary containment. Designed for dosing, metering, sampling, high lift or medium head applications in brewing, chemical processing, industrial plants, water treatment and waste water processing

Features and benefits

- ↪ Ideal for abrasive or high solid content slurries
- ↪ Self Priming, problem free pumping of gaseous liquids
- ↪ Easily pumps viscous liquids
- ↪ Gentle low shear pumping action
- ↪ Dry running capabilities
- ↪ Long life hoses
- ↪ No seals or valves

Technical data

| | | | |
|----------------------------|----------|-----------------------------------|---------|
| Maximum Flow Rate | 10.5 GPM | Maximum Medium Temperature | 176°F * |
| Maximum Discharge Pressure | 175 PSI | Maximum Incompressible Solid Size | 3/32 in |
| Maximum Suction Lift | 31 ftwc | Maximum Compressible Solid Size | 1/4 in |
| Hose ID | 25 mm | | |

* Continuous use with NR hose

Materials

| Description | Material | Paint Detail |
|----------------|---|---------------------|
| Pump Housing | Cast Iron (ASTM A48) | Green Powder Coated |
| Front Cover | Carbon Steel with Plexiglass Inspection Window | Powder Coated |
| Rotor | Cast Iron (ASTM A48) | |
| Drive Shaft | EN24T Steel | |
| Port Flange | 316 Stainless Steel Universal slotted design fits with DIN PN16, ANSI 150# & JIS10K Options: 304 Stainless Steel with Polypropylene or P.V.D.F Insert | |
| Mounting Frame | Carbon Steel | Powder Coated |
| Gearbox Flange | Aluminium | |
| Bearing | Bearing Steel | |
| Shaft Seal | Viton Option: PTFE | |
| Lubricant | Verderlube - Glycerine based lubricant Verdersil - Silicone based lubricant | |
| Hose | Natural Rubber (NR) Options: Nitrile Buna Rubber (NBR) Ethylene Propylene Diene Monomer (EPDM), Hypalon® (CSM) and Verderprene | |
| Weight | Complete pump excluding drive: 115 lb | |



Verderflex

Dura 25

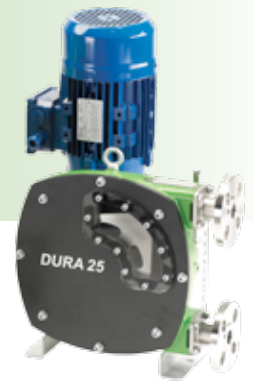

VERDERFLEX®

Standard Pump Options for 60Hz Motor Fitted With Worm Gearbox, Suitable for Inverter Duty

| Flow GPM | Pump Speed RPM | Maximum Pressure PSI |
|-------------|-------------------|-------------------------|
| 2.63 | 35 | 174 |
| 3.30 | 44 | 174 |
| 4.36 | 58 | 174 |
| 5.26 | 70 | 174 |
| 6.61 | 88 | 174 |

Performance curve

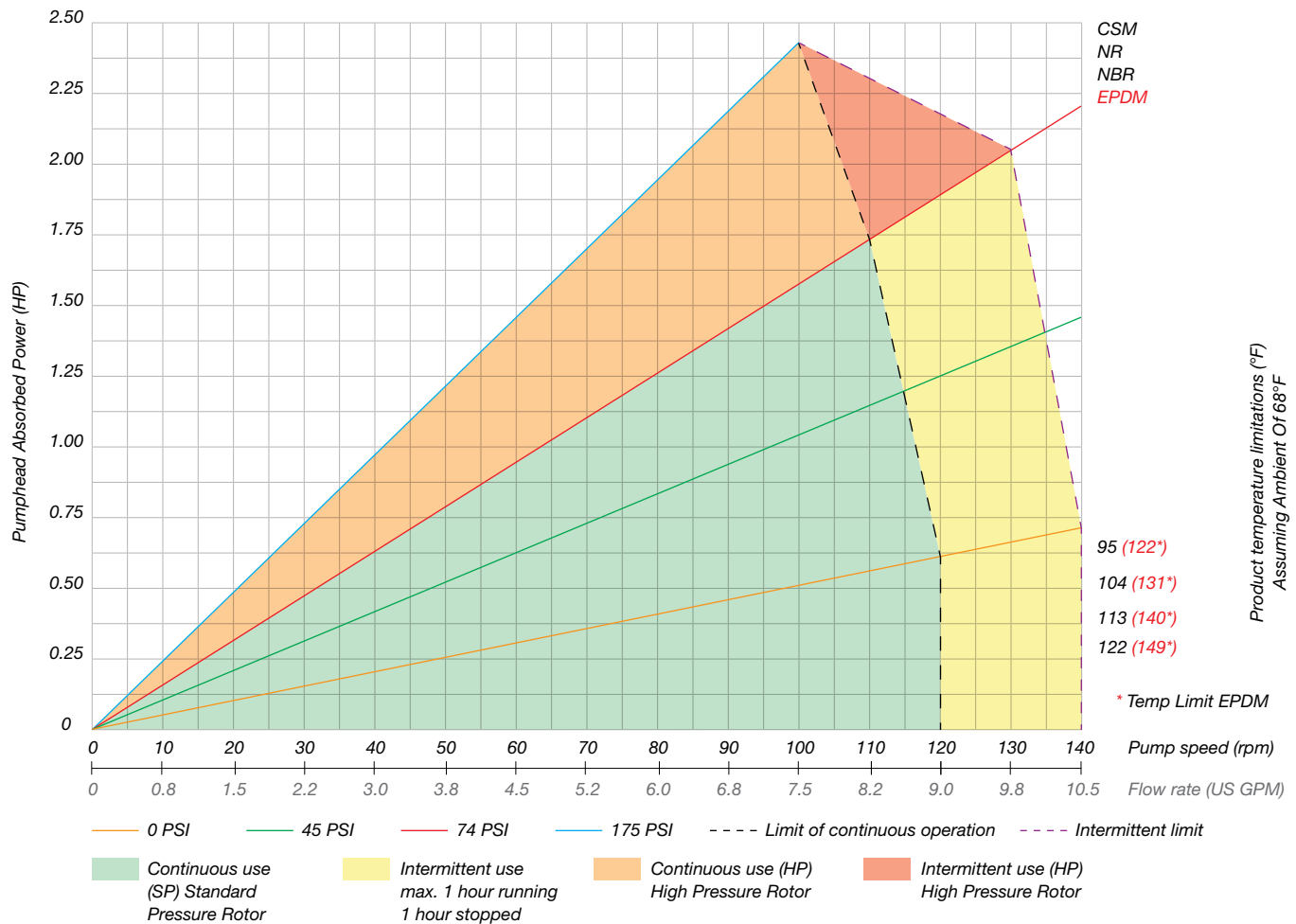

Any application below 15 Hz may require special review. Flows are typical and were measured with water at 70°F with no suction lift or discharge pressure. Actual flows will vary according to suction conditions, discharge pressure and normal component production tolerances.

DURA PUMPS OPERATING ABOVE 90 PSI REQUIRE CONSULTATION WITH MANUFACTURER OR DISTRIBUTOR.



Verderflex

Dura 25

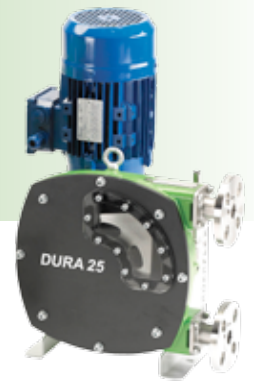

VERDERFLEX®

Dimensions

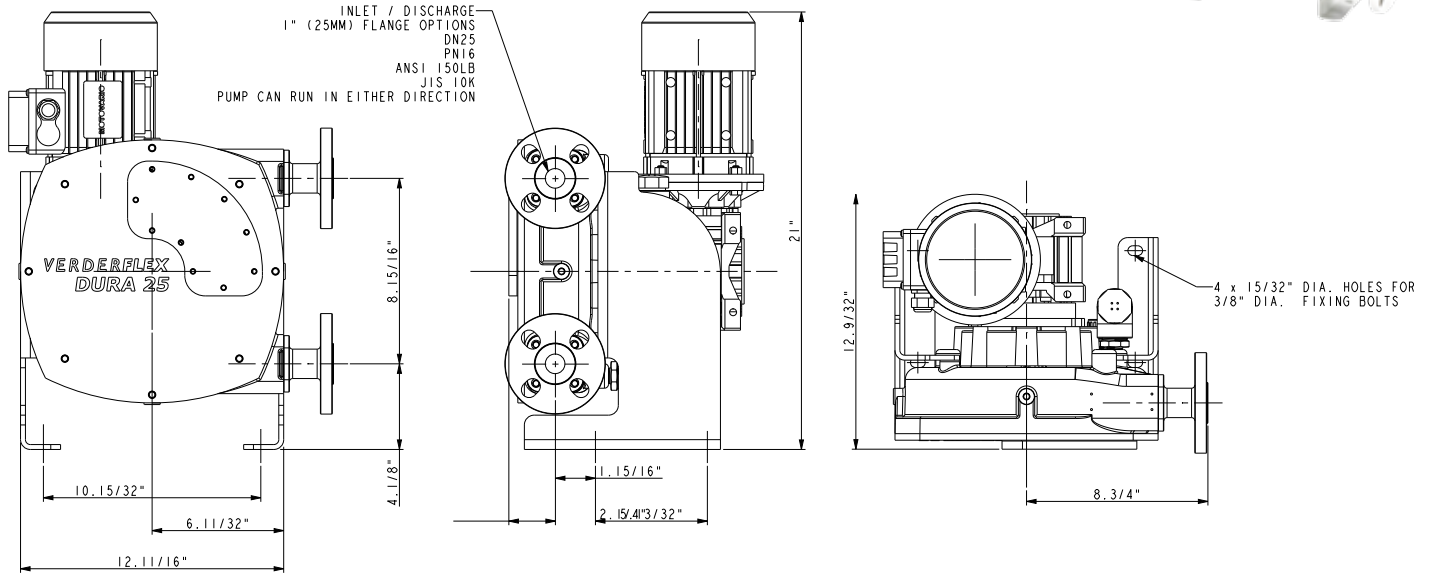

All dimensions are in inches.

All dimensions and weights are for guidance only.



Find your local supplier at www.verderflex.com

For construction, installation and floor mounting drawings
please contact your local authorised Verderflex® distributor.

VERDER
passion for pumps