

**VERDERFLEX<sup>®</sup>**

# Peristaltic OEM Tube Pump

Operating Manual

Steptronic

Version 1.0v-07/2015

Print-No. 01

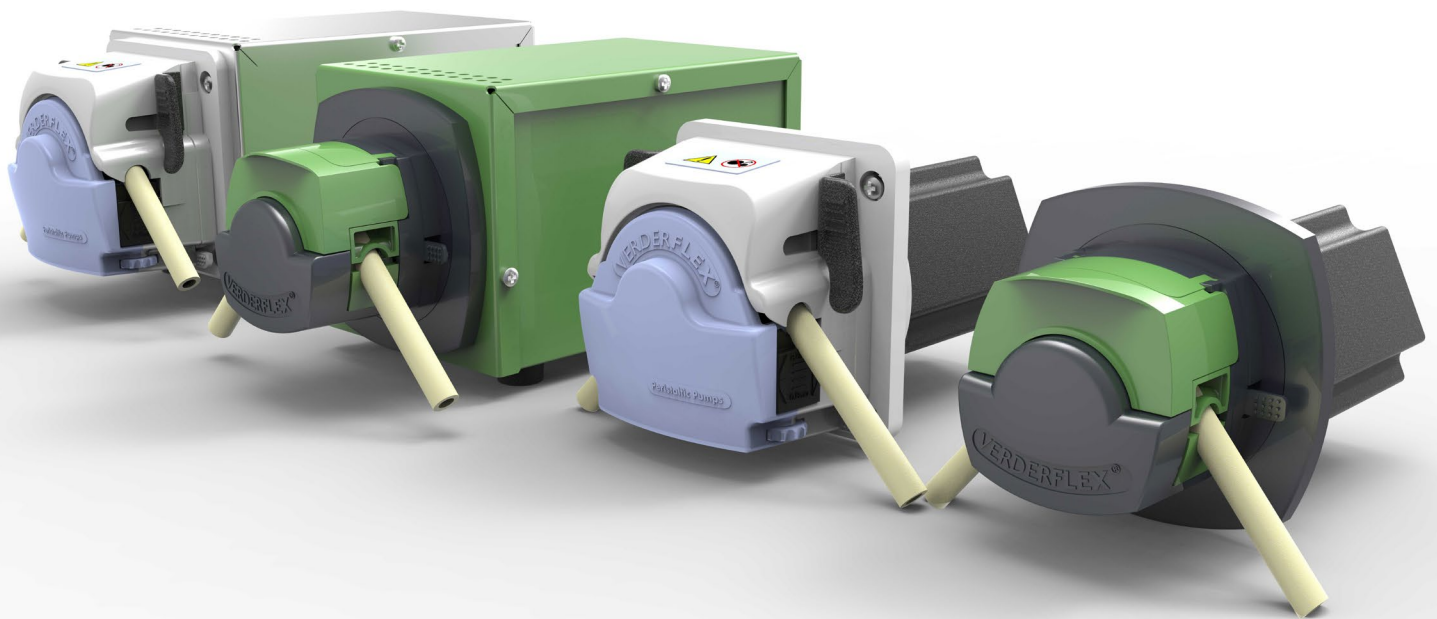

**VERDER**  
passion for pumps

Version 1.0v-07/2015  
Print-No. 01

## Verderflex Steptronic



The information in this document is essential for the safe operation and servicing of Verderflex<sup>®</sup> Steptronic family of pumps. This document must be read and understood thoroughly prior to installation of unit, electrical connection and commissioning.

# Table of contents

- 1. About this document**
  - 1.1 Target groups
  - 1.2 Warnings and symbols
- 2. Safety**
  - 2.1 Intended use
  - 2.2 General safety instructions
    - 2.2.1 Product safety
    - 2.2.2 Obligation of the operating company
    - 2.2.3 Obligation of personnel
  - 2.3 Specific hazards
    - 2.3.1 Hazardous pumped liquids
    - 2.3.2 Sharp edges
- 3. Layout and function**
  - 3.1 Design details
  - 3.2 Name plate
    - 3.2.1 Name Plate
  - 3.3 Layout - Steptronic Mini load Cased
  - 3.4 Layout - Steptronic EZ head Cased
  - 3.5 Layout - Steptronic Mini-load panel mounted
  - 3.6 Layout - Steptronic EZ head panel mounted
- 4. Transport, storage and disposal**
  - 4.1 Transport
    - 4.1.1 Unpacking and inspection on delivery
  - 4.2 Treatment for storage
  - 4.3 Interim storage before installation
  - 4.4 Disposal
- 5. Installation and connection**
  - 5.1 Preparing for installation
    - 5.1.1 Checking the ambient conditions
    - 5.1.2 Preparing the installation site
    - 5.1.3 Preparing the foundation and surface
  - 5.2 Installing the Steptronic
  - 5.3 Types of pump head
  - 5.4 Mini-load head
    - 5.4.1 Key features
    - 5.4.2 Installing the tube
    - 5.4.3 Installing the tube clamp
    - 5.4.4 Changing the tube clamp
    - 5.4.5 Replacing the pump head
    - 5.4.6 Installing a multi-channel pump head
  - 5.5 EZ head
    - 5.5.1 Key features
    - 5.5.2 Installing the tube
    - 5.5.3 Replacing the pump head
    - 5.5.4 Stacking pump head
  - 5.6 Electrical connection
    - 5.6.1 Connecting to control signal
    - 5.6.2 Connecting to power supply
- 6. Remote analogue control**
  - 6.1 Types of analogue control
  - 6.2 Layout of control pins
  - 6.3 Analogue control mode
- 7. Wiring the 25-way D-sub connector**
  - 7.1 Description of PINs
  - 7.2 Basic user controls
    - 7.2.1 Starting the pump
    - 7.2.2 Stopping the pump
    - 7.2.3 Direction of rotation
    - 7.2.4 Speed control
    - 7.2.5 Prime
    - 7.2.6 Healthy / Fault indication
  - 7.3 Factory configuration of parameters
    - 7.3.1 Selection of analogue signal
    - 7.3.2 Maximum speed
    - 7.3.3 Minimum speed
    - 7.3.4 Flow
    - 7.3.5 Ramp
    - 7.3.6 Logical low
    - 7.3.7 Error display
- 8. Inspections, maintenance and repairs**
  - 8.1 Inspections
  - 8.2 Maintenance
    - 8.2.1 Cleaning the pump
    - 8.2.2 Maintenance schedule
  - 8.3 Repairs
    - 8.3.1 Preparations for dismounting
    - 8.3.2 Returning the pump to the manufacturer
    - 8.3.3 Rebuild / Repair
  - 8.4 Ordering spare parts
- 9. Storing pumps and hoses**
  - 9.1 Pre-Storage Actions
  - 9.2 Storage Conditions
- 10. Troubleshooting**
  - 10.1 Pump malfunctions
- 11. Appendix**
  - 11.1 Technical Specifications
    - 11.1.1 Pump Specifications
    - 11.1.2 Ambient conditions
    - 11.1.3 Power supply
    - 11.1.4 Tube variants
    - 11.1.5 Turndown resolution
  - 11.2 List of Figures and Tables
    - 11.2.1 List of figures
    - 11.2.2 List of tables
  - 11.3 Declaration of conformity according to EC Machine Directive

# 1. About this document





The Verderflex Steptronic range of peristaltic pumps, have been developed according to the latest technology and subject to continuous quality control. These operating instructions are intended to facilitate familiarization with the pump and its designated use. The relevant information will act as a guideline for you in operating the pump; alternative courses of action are also described should you be unable, for any reason, to follow those procedures initially given. You are advised to follow these guidelines to achieve maximum efficiency. These operating instructions Do not take into account local regulations; the operator must ensure that such regulations are strictly observed by all, including the personnel called in for installation.

## 1.1 Target groups







Target groups	Duty
Operating company	<ul style="list-style-type: none"> <li>▶ Keep this manual available at the operation site of the equipment, also available for later reference.</li> <li>▶ Ensure that personnel read and follow the instructions in this manual and the other applicable documents, especially all safety instructions and warnings.</li> <li>▶ Observe any additional rules and regulations referring to the system.</li> </ul>
Qualified personnel, fitter	<ul style="list-style-type: none"> <li>▶ Read, observe and follow this manual and the other applicable documents, especially all safety instructions and warnings.</li> </ul>

Tab. 1 Target groups and their duties

## 1.2 Warnings and symbols

Warning	Risk Level	Consequences of disregard
	Immediate acute risk	Death, serious bodily harm
	Potential acute risk	Death, serious bodily harm
	Potential hazardous situation	Minor bodily harm
	Potential hazardous situation	Material damage

Tab. 2 Warnings and consequences of disregarding them

Symbol	Meaning
	Safety warning sign in accordance with DIN 4844 - W9 <ul style="list-style-type: none"> <li>▶ Take note of all information highlighted by the safety warning sign and follow the instructions to avoid injury or death.</li> </ul>
	Instruction
	Multiple-step instructions
	Precondition
	Cross-reference
	Information, recommendation

Tab. 3 Symbols and their meaning

## 2. Safety

 The manufacturer does not accept any liability for damage resulting from disregard of this documentation.

### 2.1 Intended use

- ▶ Only use the pump to handle compatible fluids as recommended by the manufacturer (→ 12.1 Technical specifications).
- ▶ Adhere to the operating limits.
- ▶ Consult the manufacturer regarding any other use of the pump.

#### Prevention of obvious misuse (examples)

- ▶ Note the operating limits of the pump with regard to temperature, pressure, flow rate and motor speed (→ 12.1 Technical specifications).
- ▶ Do not operate the pump while the inlet/outlet valve is closed.
- ▶ Only install the pump as recommended in this manual. For example, the following are not allowed:
  - Installing the pump without proper support.
  - Installation in the immediate vicinity of extreme hot or cold sources.
  - Explosive atmosphere

### 2.2 General safety instructions

 Observe the following regulations before carrying out any work.

#### 2.2.1 Product safety

These operating instructions contain fundamental information which must be complied with during installation, operation and maintenance. Therefore this operating manual must be read and understood both by the installing personnel and the responsible trained personnel / operators prior to installation and commissioning, and it must always be kept easily accessible within the operating premises of the machine.

- ▶ Not only must the general safety instructions laid down in this chapter on “Safety” be complied with, but also the safety instructions outlined under specific headings.
- ▶ Operate the pump only if the pumping unit and all associated systems are in good functional condition.  
Only use the pumping system as intended, fully aware of safety and risk factors involved,

- and in adherence to the instructions in this manual.
- ▶ Keep this manual and all other applicable documents complete, legible and accessible to personnel at all times.
- ▶ Refrain from any procedure or action that would pose a risk to personnel or third parties.
- ▶ In the event of any safety-relevant faults, shut down the pump immediately and have the malfunction corrected by qualified personnel.
- ▶ The installation of the pump, associated pipe work and electrical fittings must comply with the requirements of installation given in this manual and any local national or regional health and safety regulations.

#### 2.2.2 Obligation of the operating company

##### Safety-conscious operation

- ▶ Ensure that the following safety aspects are observed and monitored:
  - Adherence to intended use
  - Statutory or other safety and accident-prevention regulations
  - Safety regulations governing the handling of hazardous substances if applicable
  - Applicable standards and guidelines in the country where the pump is operated
- ▶ Make personal protective equipment available pertinent to operation of the pump; as required.

##### Qualified personnel

- ▶ Ensure that all personnel tasked with work on the pump have read and understood this manual and all other applicable documents, including the safety, maintenance and repair information, prior to use or installation of the pump.
- ▶ Organize responsibilities, areas of competence and the supervision of personnel.
- ▶ Have all work carried out by specialist technicians only.
- ▶ Ensure that trainee personnel are under the supervision of specialist technicians, at all times, when working on the pumping system.

##### Safety equipment

- ▶ Provide the following safety equipment and verify its functionality:
  - For hot, cold and moving parts: safety guarding should be provided by the operating company.
  - For potential build up of electrostatic charge: ensure appropriate grounding if and when required.

## Warranty

**i** The warranty is voided if the customer fails to follow any and all instructions, warnings and cautions in this document. Verder has made every effort to illustrate and describe the product(s) in this document. Such illustrations and descriptions are, however, for the sole purpose of identification and do not express or imply a warranty that the products are merchantable or fit for a particular purpose, or that the products will necessarily conform to the illustration or descriptions.

Obtain the manufacturer's approval prior to carrying out any modifications, repairs or alterations during the warranty period. Only use genuine parts or parts that have been approved by the manufacturer.

For further details regarding warranty, please refer terms and conditions.

### 2.2.3 Obligation of personnel

**i** It is imperative that the instructions contained in this manual are complied with by the operating personnel at all times.

- ▶ Pump and associated components:
  - Do not lean or step on them or use as climbing aid
  - Do not use them to support boards, ramps or beams
  - Do not de-ice using gas burners or similar tools
- ▶ Do not remove the safety guarding for hot, cold or moving parts during operation.
- ▶ Reinstall the safety equipment on the pump as required by regulations after any repair / maintenance work on the pump.

## 2.3 Specific hazards

### 2.3.1 Hazardous pumped liquids

- ▶ Follow the statutory safety regulations when handling hazardous pumped liquids (e.g. hot, flammable, poisonous or potentially harmful).
- ▶ Use appropriate personal protective equipment when carrying out any work on the pump.

### 2.3.2 Sharp edges

- ▶ Pump parts can be sharp
  - Use protective gloves when carrying out any work on the pump

## 3. Layout and function

**i** Peristaltic OEM tube pump, Verderflex Steptronic, is simple by design in its construction and operation. The medium to be pumped does not come into contact with any moving parts and is totally contained within a tube. A rotor passes along the length of the tube, compressing it. This motion forces the contents of the tube directly in front of the rotor to move forward along the length of the tube in a 'positive displacement', peristaltic movement. In the wake of the rotor's compressing action, the natural elasticity of the tube material forces the tube to open and regain its round profile, creating suction pressure, which recharges the pump.

### 3.1 Design details

**i** The Verderflex Steptronic range of tube pumps provide a balanced selection of simple to operate peristaltic pumps. The family offers the customer pump choices that are compact, can have multiple heads, are simple by design, with rapid tube changeovers and 4000:1 turn-down ratio with the stepper drive.

### 3.2 Name plate

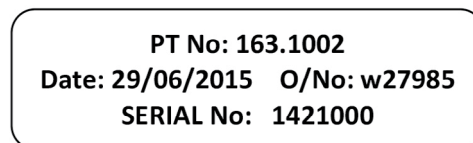
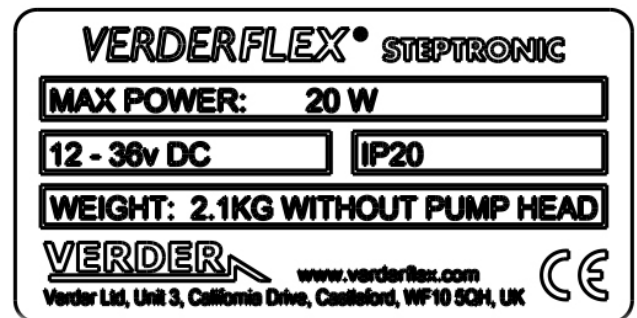

Figure 1: Name plate

**Note:** When requesting spares, the model and serial number should always be quoted.



## 3.4 Layout – Steptronic Mini-load Cased Version

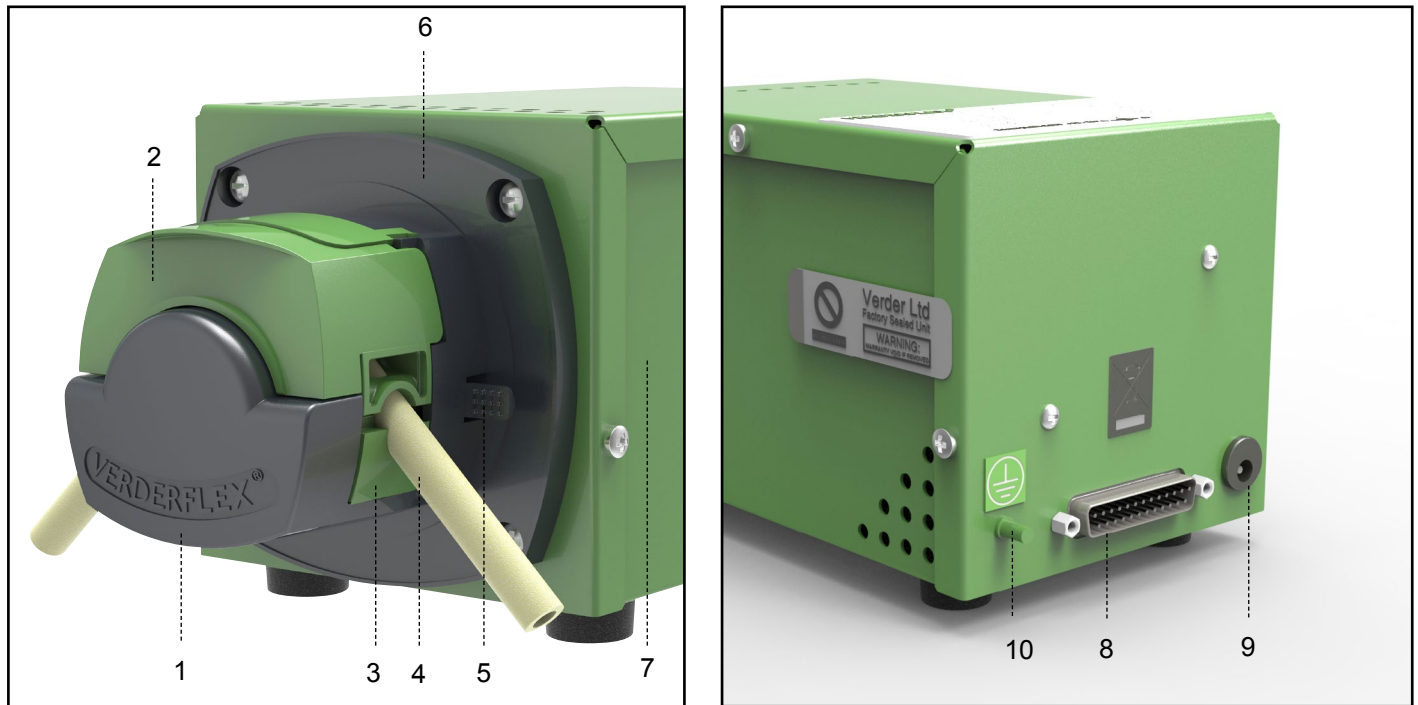

Figure 2. Layout

- |                       |                           |                          |
|-----------------------|---------------------------|--------------------------|
| 1 Front cover         | 5 Pump-head release lever | 8 25 way D-sub connector |
| 2 Tube saddle         | 6 Back plate              | 9 Power sockets          |
| 3 Tube clamp assembly | 7 Pump casing             | 10 Earth connector       |
| 4 Tube element        |                           |                          |

## 3.5 Layout – Steptronic EZ Cased Version

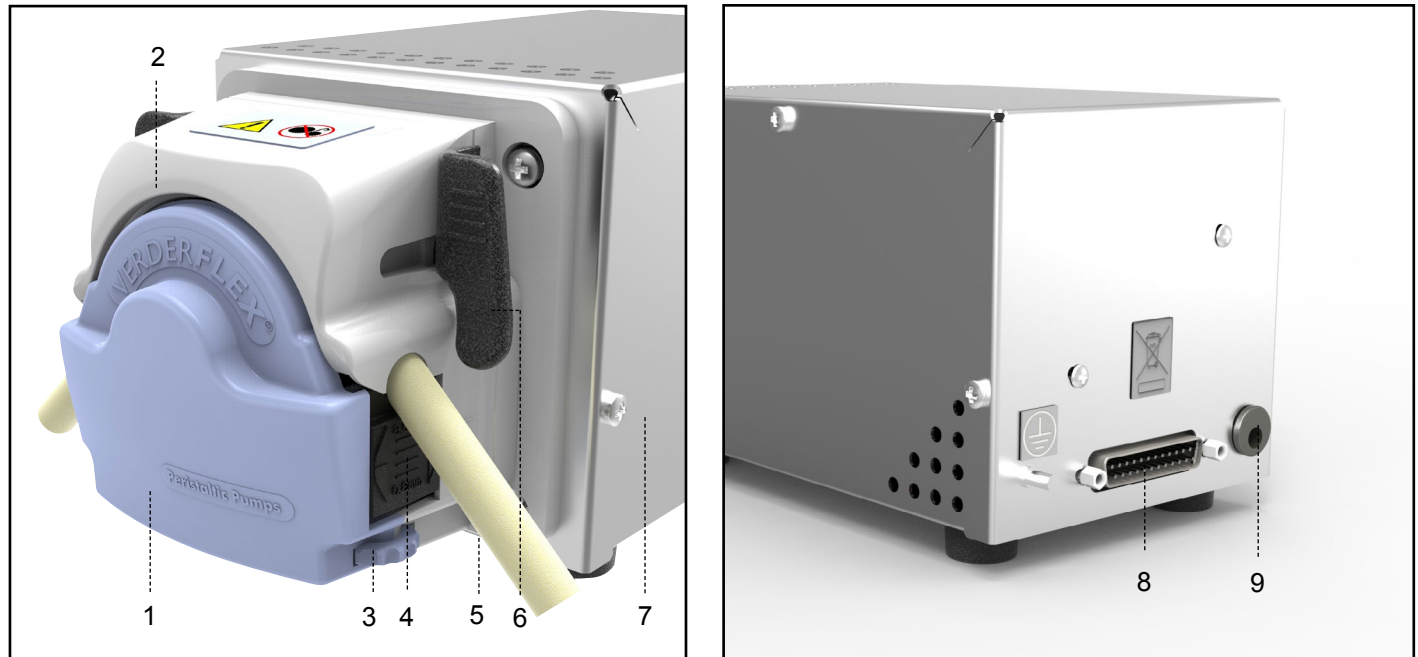

Figure 3. Layout

- |                       |                           |                    |
|-----------------------|---------------------------|--------------------|
| 1 Front cover         | 5 Pump-head release lever | 8 25 way D-sub     |
| 2 Tube saddle         | 6 Lugs                    | 9 Power socket     |
| 3 Variable tube clamp | 7 Pump body               | 10 Earth connector |
| 4 Tube clamp assembly |                           |                    |

### 3.6 Layout – Steptronic Mini-load Panel Mounted Version

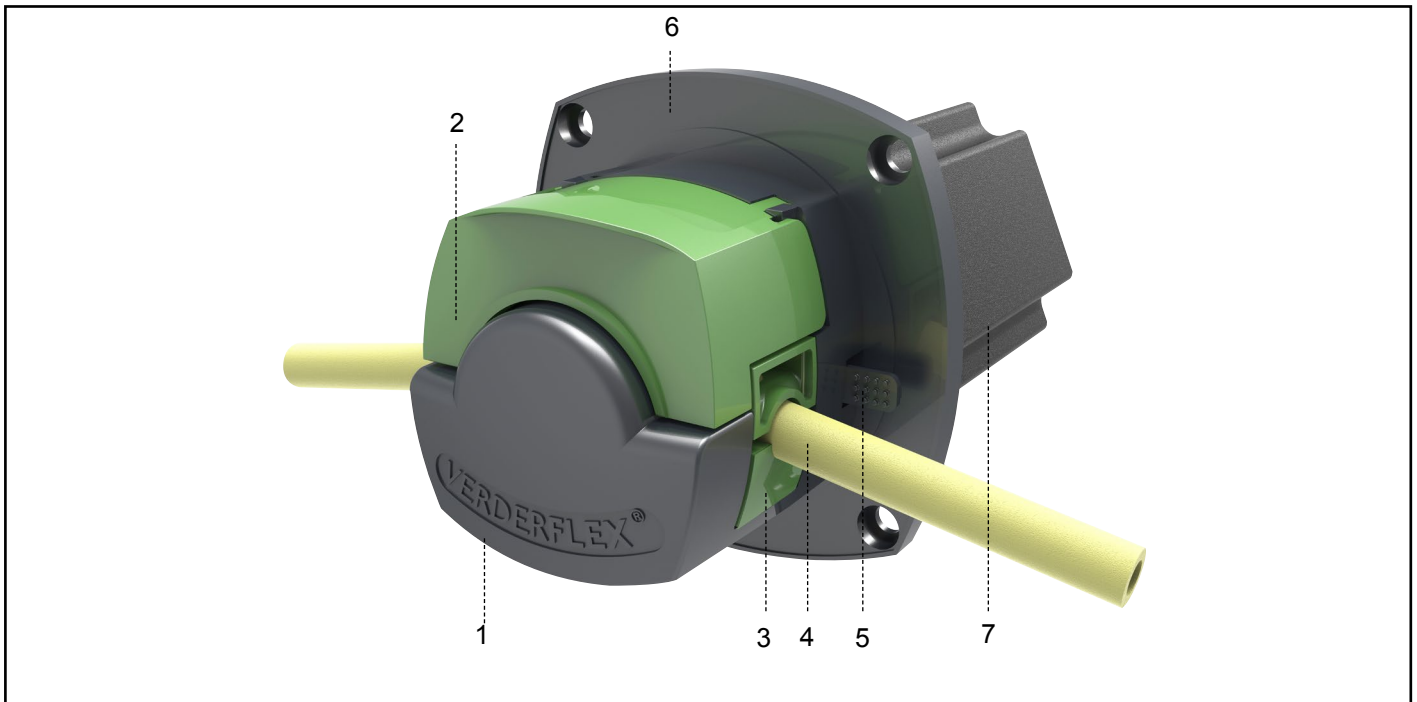

Figure 4. Layout

- |   |                     |   |                         |   |               |
|---|---------------------|---|-------------------------|---|---------------|
| 1 | Front cover         | 4 | Tube element            | 6 | Back plate    |
| 2 | Tube saddle         | 5 | Pump-head release lever | 7 | Stepper motor |
| 3 | Tube clamp assembly |   |                         |   |               |

### 3.7 Layout – Steptronic EZ-head Panel Mounted Version

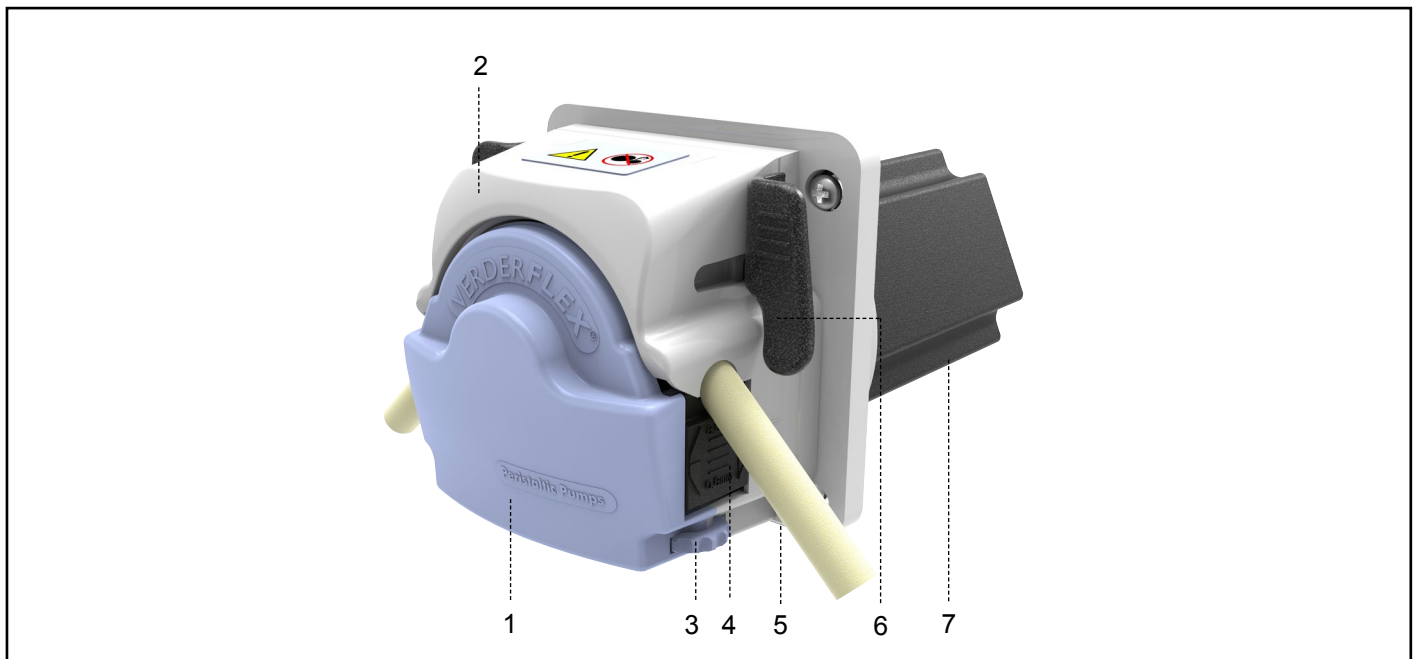



Figure 5. Layout

- |   |                     |   |                         |   |               |
|---|---------------------|---|-------------------------|---|---------------|
| 1 | Front cover         | 4 | Tube clamp assembly     | 7 | Stepper drive |
| 2 | Tube saddle         | 5 | Pump-head release lever |   |               |
| 3 | Variable tube clamp | 6 | Lugs                    |   |               |



## 4. Transport, storage and disposal

### 4.1 Transport

 Always transport the unit in an upright position and ensure that the unit is securely packed in the box.

#### 4.1.1 Unpacking and inspection on delivery

1. Unpack the pump/pump unit upon delivery and inspect it for transport damage.
2. Report any transport damage to the manufacturer/distributor immediately.
3. Retain the packing if any further transport is required.
4. Dispose all packaging material according to local regulations.

### 4.2 Treatment for storage

 The unit should be stored in a dry, dust free environment not exceeding 60°C

### 4.3 Interim storage before installation

 Make sure the storage room meets the following conditions:

- Dry, humidity not to exceed 80%
- Out of direct sunlight
- Frost-free; temperature range 0 to 40°C
- Vibration-free; minimize
- Dust-free; minimize

## 4.4 Disposal

-  With prolonged use, pump parts can get contaminated by pumped liquids to such an extent that cleaning may be insufficient.

### WARNING

#### Risk of poisoning and environmental damage by the pumped liquid or oil!

- ▶ Use suitable personal protective equipment when carrying out any work on the pump.
- ▶ Prior to disposal of the pump:
  - Collect and dispose of any leaking pumped liquid or oil in accordance with local regulations.
  - Neutralize residues of pumped liquid in the pump.
- ▶ Dispose of the pump unit and associated parts in accordance with statutory regulations.

## 5. Installation and connection

### NOTE

#### Material damage due to unauthorized modification on pump unit!

- ▶ Do not make any structural modifications to the pump unit or pump casing
- ▶ Do not carry out any welding work on the pump unit or pump casing

### NOTE

#### Material damage caused by ingress!

- Do not remove any protective flange covers until immediately before connecting the pipes to the pump

## 5.1 Preparing for installation

### 5.1.1 Checking the ambient conditions

1. Make sure that the operating conditions are complied with (→ 11.1 Technical specifications)
2. Make sure the required ambient conditions are fulfilled (→ 11.1.2 Ambient conditions)

### 5.1.2 Preparing the installation site

- ▶ Ensure the installation site meets the following conditions:
  - Pump is freely accessible from all sides
  - Sufficient space is available for the installation/removal of the pipes and for maintenance and repair work, especially for the removal and installation of the tube.

### 5.1.3 Preparing the surface

- ▶ Make sure the surface meet the following conditions:
  - Level
  - Clean (no oil, dust or other impurities)
  - Capable of bearing the weight of the pump unit and all operating forces
  - Ensure the pump is stable and cannot tip over

## 5.2 Installing the Steptronic

### 5.2.1 Key features

-  Robust design with thick wall tube for suction and pressure handling.

1. Flow rates up to 380 ml/min (6.02 US GPH) with Mini-load head; 1,310 ml/min (20.76 US GPH) with EZ-load head
2. Pressures up to 2 Bar (29 PSI) depending on tube material
3. Turndown ratio is 4096:1

### 5.2.2 Description of the Pump Head

-  The pump head comprises three main parts:

1. The rotor with rollers which is responsible for the peristaltic action of the pump
2. The main body, which carries the rotor and tube saddle / tube clamp arrangement.
3. The tube saddle, this is moveable to permit easy tube installation.

## 5.3 Types of pump head

 Verderflex® Steptronic range of pumps are available with the new mini-load pump head (which is also available as an OEM pump head), as well as the EZ head featured on the Verderflex Vantage 3000 tube pump providing greater flow rates.



	
1. Mini load Head	2. EZ Head

Table 4 Steptronic pump head options

## 5.4 Mini-load (ML) head

### 5.4.1 Key features

Easy tube change, dual pump head option with Verderprene, Silicone, Viton® or Tygon® tubing.

- Flow rates up to 380 ml/min ((6.02 US GPH) (with single pump head)
- Pressures up to 2 Bar (29 PSI) depending on tube material
- Maximum speed 409.6 rpm (with single head)
- Typically used in frequent tube change applications

### 5.4.2 Installing the tube

1. Lift the tube saddle by operating the lever (Refer fig.6)
2. Place the tube into gap between the rollers at the tube saddle.
3. Check the tube is aligned with the gap in the tube clamps and tube saddle so the tube is held correctly and not damaged.
4. Ensure correctly sized tube clamps are used for the tube being installed (refer - 5.4.3, Installing the tube clamp).
5. Operate the lever to close the tube saddle assembly onto the tube to assemble it into the working position.

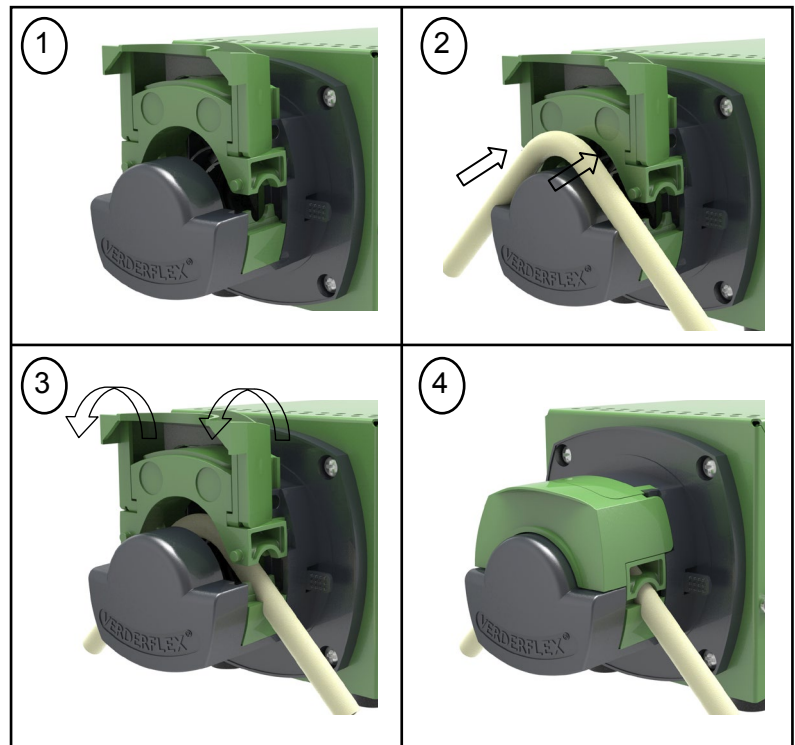



Figure 6. Installing tube in to a Mini-load head

## 5.4.3 Installing the tube clamp

 The tube clamps for the Miniload are a fixed size design, for each of the 4 tube sizes it is designed to operate with.

To insert the tube clamps:

1. Raise the tube saddle by operating the lever.
2. Offer the tube clamp horizontal to the pump main body (refer Fig. 7) note the spigots to each side of the tube clamp, they are designed to fit in two grooves in the pump head main body.
3. Rotate the tube clamp slide down with the two spigots located in the grooves, until a click is heard as the tube clamp locates in the slot.

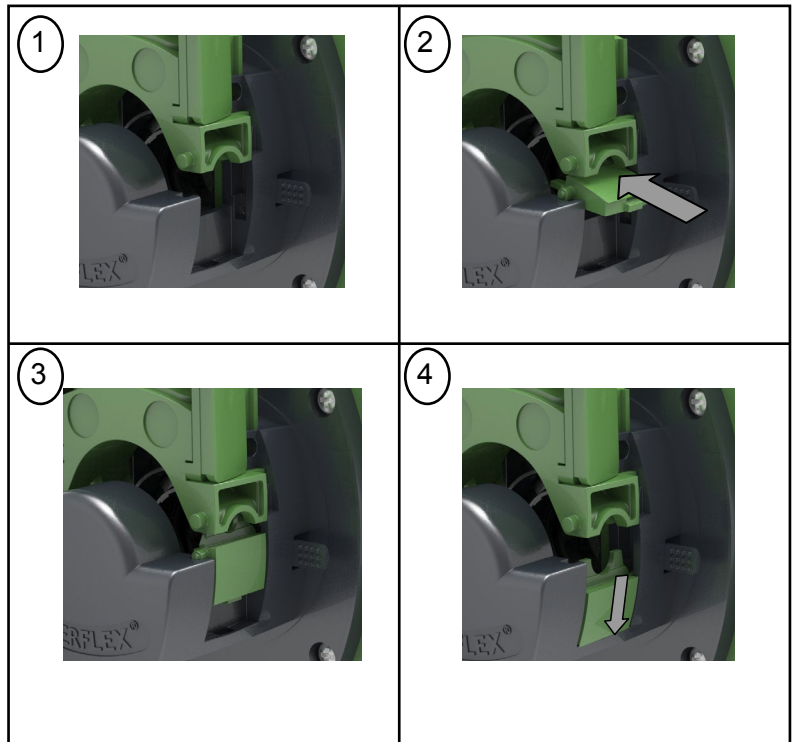

Figure 7. Installing tube clamp

## 5.4.4 Changing the tube clamp

To change the tube clamps:

1. Gently insert a small flat blade screw driver (max size 5mm) into the gap at the base of the tube clamp.
2. Rotate the screwdriver to overcome the slot.
3. Ensure the tube is aligned with the gap in the tube clamps and tube saddle so the tube is held correctly and not damaged.
4. Remove the tube clamp, by lifting and rotating in the clamp on each side.

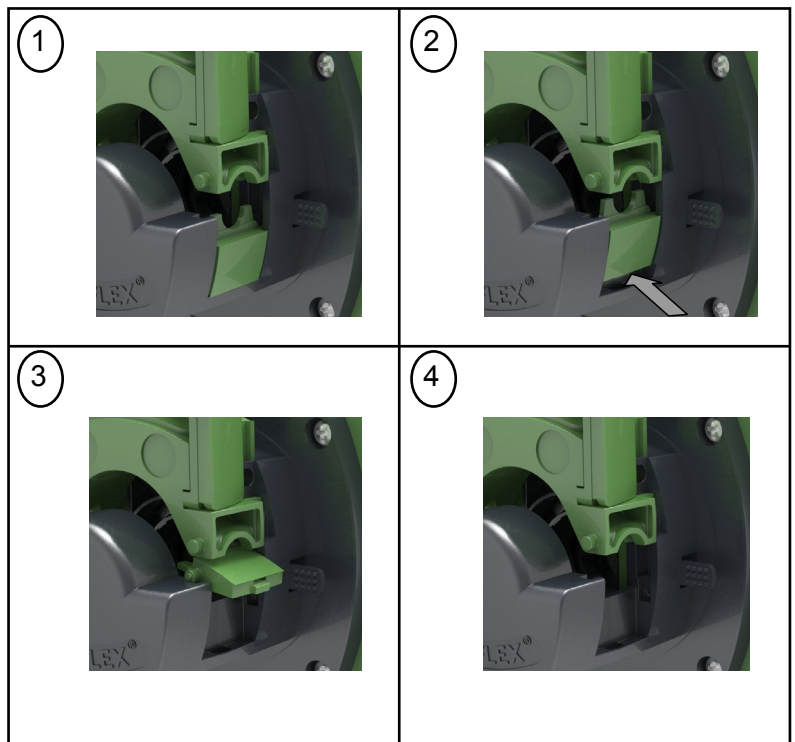

Figure 8. Changing tube clamp

## 5.4.5 Replacing the pump head

1. Remove the pump head by pressing location lever and twisting pump head counter clockwise 45°
2. Offer the new pump head to the back plate at an angle locating the motor shaft to the rotor shaft within the pump head backplate at approx 45° to vertical, locating the lugs in the housing.
3. Push and twist until location lever clicks into position

## 5.4.6 Installing a Stackable ML-pump head

Installing a stackable ML pump head is very similar to the procedure of fixing a standard pump head.

However, please note: The two pump heads of a stacked assembly will be factory assembled and configured as such. Whilst a standard pump head can be converted into a double pump head assembly, it is not recommended for the customer to do so without consultation with the manufacturer.



1. Before assembling, please observe slot in the end of the "rear" stack head as assembly and the pin front assembly drive shaft (see enlarged view 3, 4 in fig.10).
2. Align the pin and slot, offer pump head to backplate at an angle locating motor shaft and rotor shaft with pump head at approximately 45° to vertical, locating back plate lugs in housing.
3. Push and twist until location lever clicks into position
4. Remove by pressing location lever and twisting pump head counter clockwise 45°

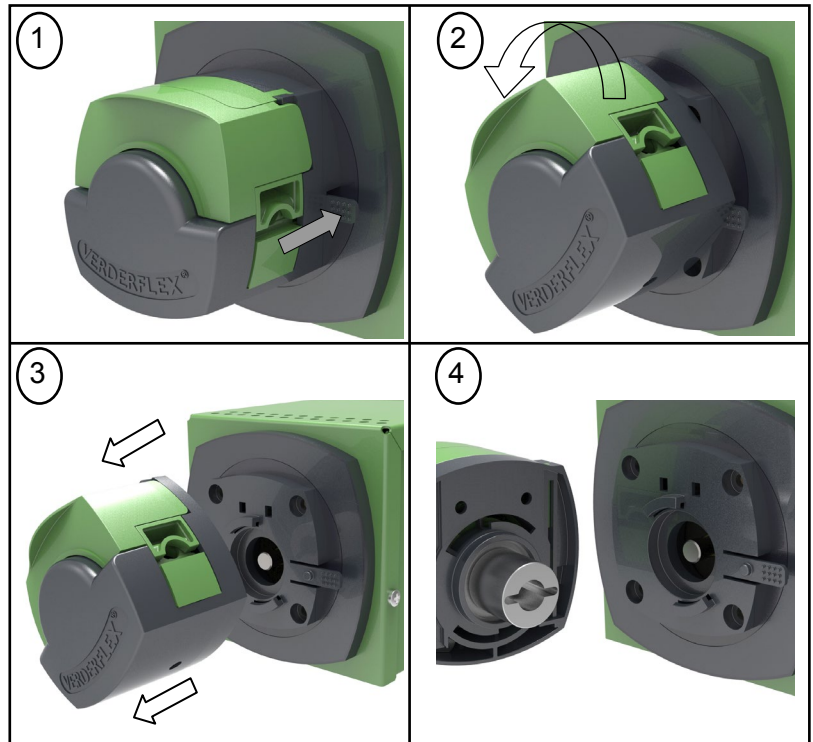

Figure 9. Installing tube on a Steptronic ML

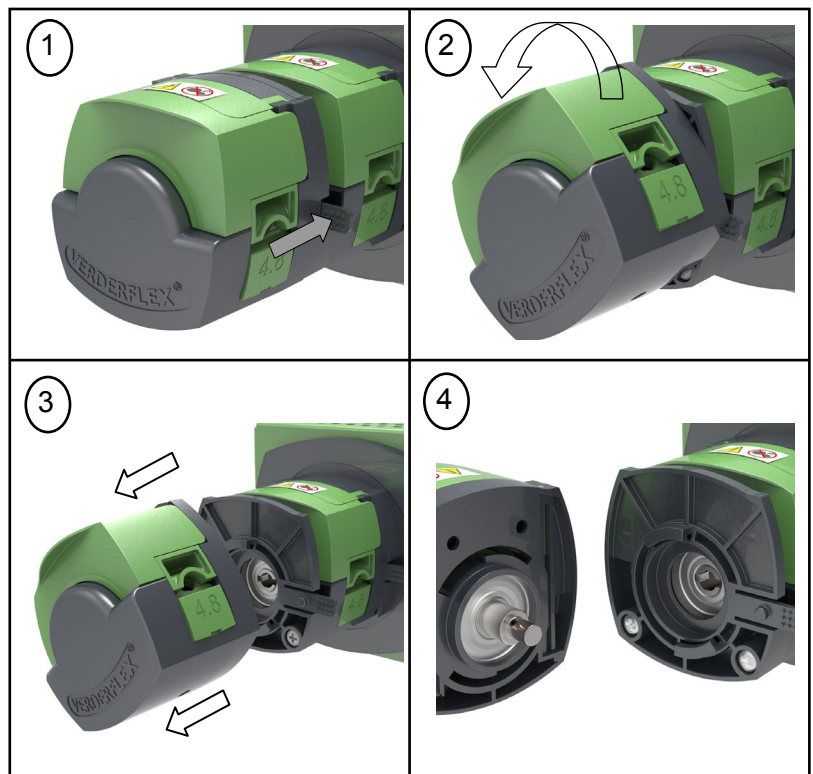

Figure 10. Installing tube on a Steptronic ML



## 5.5 EZ head

### 5.5.1 Key features

Easy tube change system, stackable multi head options with Verderprene, Silicone, Viton® or Tygon® tubing.

- Flow rates up to 1,310 ml/min (20.8 US GPH) (with single pump head)
- Pressures up to 2 Bar (29 PSI) depending on tube material
- Maximum speed 250rpm (with single pump head)
- Typically used in frequent tube change applications

### 5.5.2 Installing the tube in an EZ-head

1. Flip the lugs on both sides of the pump head to lift the top section
2. Once the head is lifted as shown in figure, insert the tube over the rollers.
3. Flip the lugs on both sides of the pump head to lock the top section down.
  - Adjust the tube clamp to hold the tube in place and avoid slip
  - Adjust the tube clamp on both sides of the pump head to the tube diameter.
  - If a tube slip is observed, tighten the tension on the clamps

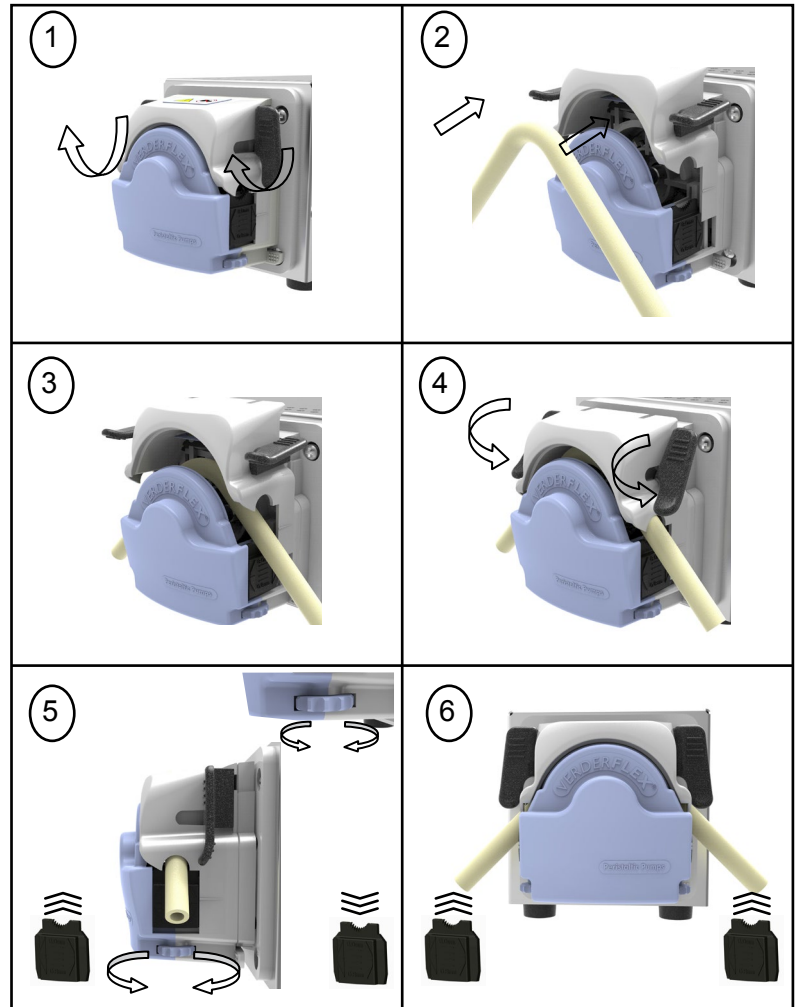

Figure 11. Installing the tube on EZ head

### 5.5.3 Replacing the pump head – EZ head

1. Offer pump head to backplate at angle locating drive shaft and rotor shaft with pump head at approx 45° to vertical, locating backplate lugs in housing.
2. Push and twist until location lever clicks into position
3. Remove by depressing location lever and twisting pump head counter clockwise 45°

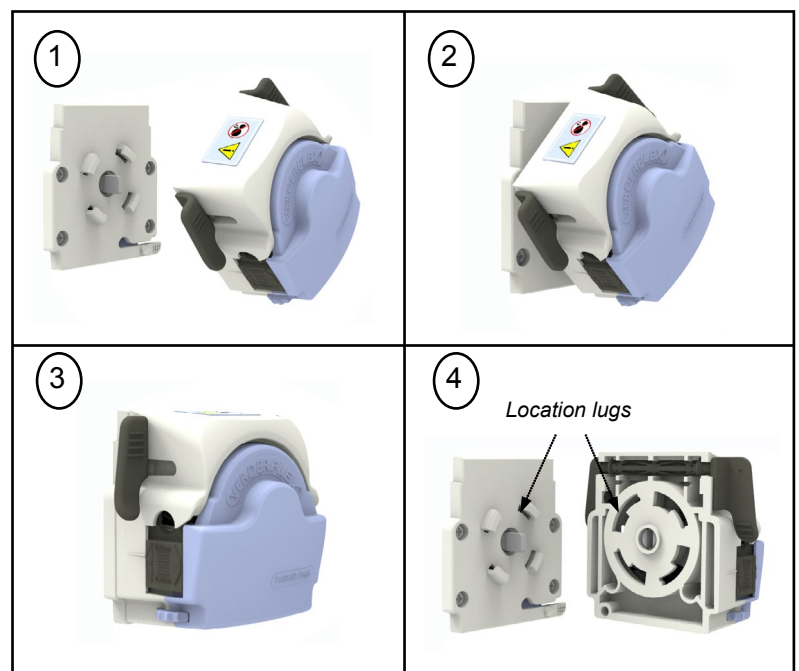

Figure 12. Replacing pump head – EZ head



## 5.5.4 Stacking pump head ES-stackable pump head on EZ- pump head



A pump head can be stacked over a similar stackable head as demonstrated in table 6.

1. Attach the stackable head on to the backplate (refer 5.5.3 )
2. Offer the pump head over the stackable head locating the drive shaft and pump shaft with pump head at approx 45° to vertical, locating lugs in the housing.
3. Push and twist unit location lever clicks into position.
4. Remove by depresssing location lever on the stackable head and twisting

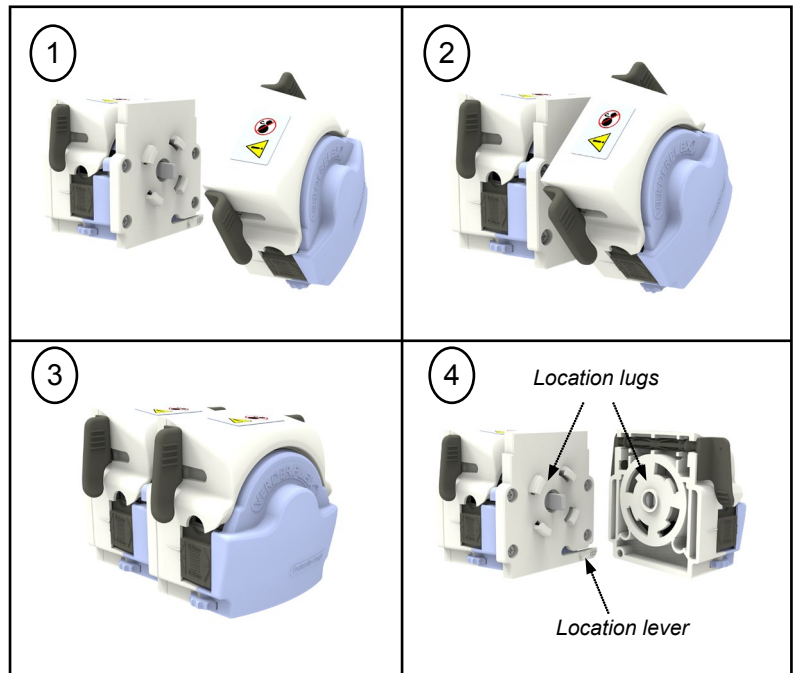

Figure 13. Stacking – ES head

## 5.6 Electrical connection

### DANGER

#### Risk of electrocution!

- ▶ All electrical work must be carried out by qualified electricians.
- ▶ Make sure that the electrical information on the rating plate agrees with the power supply.
- ▶ Isolate the main supply before replacing the tube/cartridge
- ▶ Isolate the main supply before removing the enclosure cover.

### 5.6.1 Connecting to Control Signals

#### NOTE

#### Pump cannot be operated before wiring the D-25 pins

- ▶ Pump cannot be operated before wiring the D-25 cable as per wiring diagram in Fig.16
- ▶ The pump should be connected to external 0-10V or 4-20 mA control signal through the D-25 ribbon cable (for panel mounted versions) or the D-25 pins (for cased version) before operation.

### 5.6.2 Connecting to power supply

1. Connect motor to the rated power supply (Refer 11.1 Technical specification). Ensure the earth connection is made and secured.
2. Run the pump slowly to ensure correct rotation.

### DANGER

#### Risk of injury and poisoning due to pumped liquid spraying out!

- ▶ Use personal protective equipment when carrying out any work on the pump.

### WARNING

#### Risk of injury and poisoning due to hazardous pumped liquids!

Safely collect any leaking pumped liquid and dispose of it in accordance with environmental rules and requirements.

### DANGER

#### Equipment damage due to excess pressure!

- ▶ Do not operate the pump with the discharge-side fitting closed.
- ▶ Operate the pump only inside the tolerances specified by the manufacturer (→ 11.1 Technical specifications)

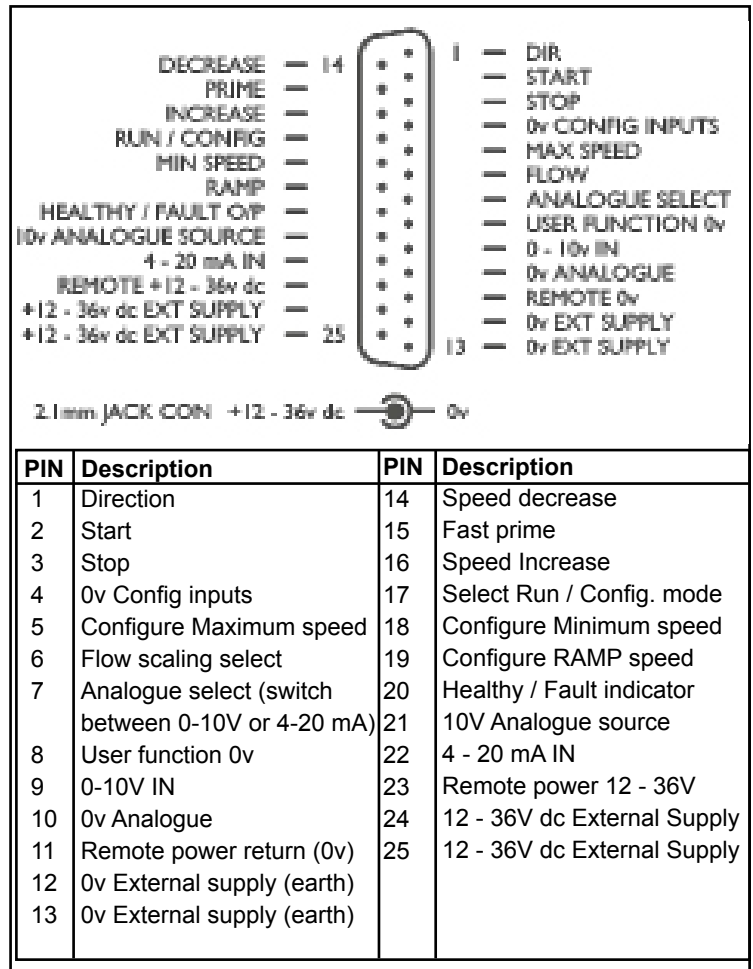

Tab. 5 25-way D-sub pin connection

## 6. Remote Analogue Control

An external Analogue/Digital control should be used to operate the Verderflex Steptronic range. Pump cannot be operated before wiring the D-25 pins.

### 6.1 Types of Analogue remote control:

- 0 - 10V D.C
- 4 – 20 mA

### 6.2 Layout of Back Plate

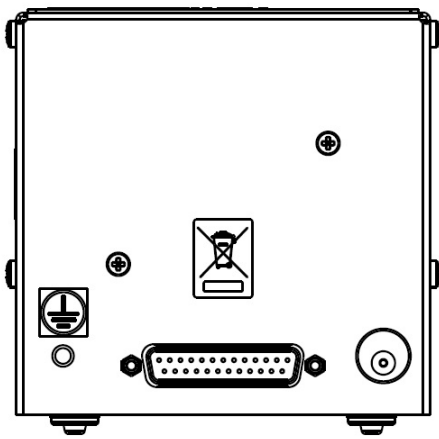

Figure 14. Backplate - Standard (without Configuration port)

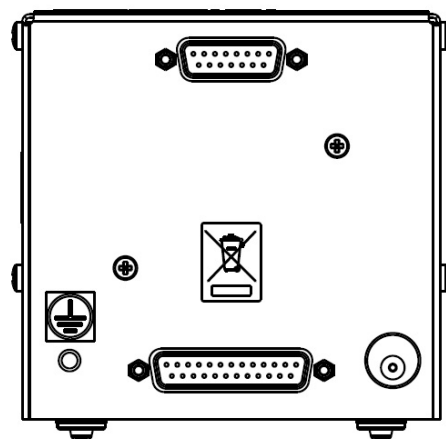

Figure 15. Backplate - With HMI port for configuration

Model	Analogue Control	
	0-10V d.c	4-20mA
Panel mount Mini-load	✓	✓
Panel mount EZ head	✓	✓
Cased 25 way D sub	✓	✓
Case 25 way D sub with HMI connection	✓	✓

Tab. 6: Models & Control features available

### 6.3 Analogue control mode

Analogue Control Mode (ACM mode) can be used with an optional HMI display to view parameters and their values. A fixed pre-configured flow-rate cannot be set in this mode. Flow-rate control is derived from an external analogue (0-10Vdc or 4-20mA) source such as a process controller or potentiometer. Without an HMI display, changes to the flow rate must be gauged by alternative means.

Switching the "START" input on, allows the pump to run indefinitely until the "START" input is released. The pump will now decelerate to a stopped condition using the pre-configured ramp rate. The "STOP" input can be used as an auxiliary stop command, which will stop the pump immediately ignoring any ramp deceleration value applied.

## 7. Wiring the 25-way D-sub connector

### 7.1 Description of PINs:

The PINs on the 25-way D-sub connector can be grouped into:

1. Pump operation controls
2. Configuration PINs (for factory configuration)
3. Fault indicator
4. Power source
5. Remote external optional power source

### 7.2 USER CONTROLS

Control features available with the Analogue 4-20mA / 0-10V are:

1. Start/ Run
2. Stop
3. Direction of rotation
4. Speed control
5. Prime
6. Fault indicator

#### 7.2.1 Starting the pump

A logical low level on the Start input will start the pump. The pump will then accelerate to its set flow-rate. The flow-rate is determined by a 12 bit resolution value (Pin 9, 25w D-sub). Volts or (Pin 22, 25w D-sub) Amps. Removal of the logical low signal to the start input will decelerate the pump to a stopped condition. In Analogue speed control mode, the STOP input can be used as a Quick stop, which will override any deceleration ramp.

### 25 way D-sub remote control connector

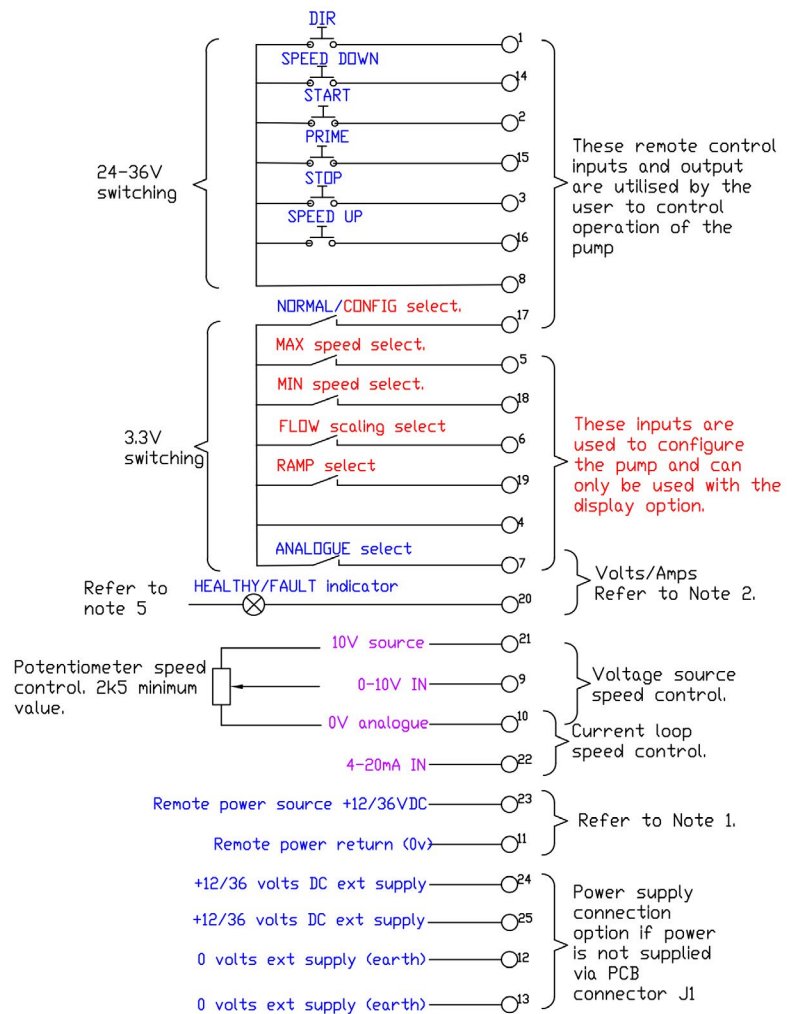

#### NOTES.

1. Remote control power source can be selected by J9 & J10 links. If the links are connected, then the remote control inputs and the fault output are controlled by the same power supply that is fed via PCB J1 or D-sub 25way pins 12/13 & 24/25(Local). If the J9/J10 links are removed, then a separate power source (12-36Vdc) for the remote control inputs and fault output can be connected to 25W D-sub pins 11 & 23 (Remote). Both J9 & J10 links must be connected or disconnected. Irreparable damage will occur if a remote source is used with the links engaged.
2. In Analogue speed control mode, A closed connection between pins 4 & 7 permits speed control via 4-20mA current loop. Maximum safe current draw is 27mA. An open connection permits speed control via 0-10 Volts. Maximum input must not exceed 13.0 Volts.
3. Refer to product data plate for configured Speed setting of fixed speed digit.
4. Fault output is normally high when healthy and switches low when in fault. If "Remote Power source" is used, (J9 & J10 links removed) then connect one side of the indicator to the + "Remote Power source (pin23)" and the return side to pin 20. If "Local power" is used, (J9 & J10 links connected) then connect one side of the indicator to "+ Local Power (Pin24/25)" and the return side to pin 20.

Figure 16. Wiring the 25-way D-sub connection

## 7.2.2 Stopping the pump

A logical low level on this input (Pin 3, 25w D-sub) will cause the pump to decelerate to a stop even if the start input is left logically low (ON). In OEM mode this input can be used as a “Quick Stop” or global stop command.

The usual way to stop the pump here would simply be to remove the logical low command from the Start input. The stop input must be switched logically high (OFF) before a restart command can be accepted. The “Start” input must then be toggled from high to low for the restart command to be accepted.

## 7.2.3 Direction of rotation

Only when the pump is in a stopped condition can the pump’s direction be changed by latching this logical input low on this pin (Pin 1, 25w D-sub). Removing the input (when stopped) will reverse the rotation back again. When used with an HMI display, an indicator “<” or “>” will be displayed.

## 7.2.4 Speed Control

In Analogue mode, speed can be increased or decreased by controlling either the 0-10V signal supplied through Pin 9, 10, 21 or through varying the 4-20mA current signal supplied through PIN 10, 22.

## 7.2.5 Prime

A logical low level will accelerate the pump to its pre-set maximum speed. Prime only works providing the pump is initially in a stopped state. Prime has no function when the pump is running normally.

## 7.2.6 Healthy / Fault:

(Pin 20, 25w D-sub)

This logical output is high (OFF) when the pump is healthy and logically low when in fault. The fault condition is usually as a result of an under/ over supply voltage condition. If the fault cannot be reset by cycling the power supply, then this would indicate a problem with the motor or drive electronics.

If the pump is configured so the control I/O and the motor power come from the same source, then the output voltage on this output is relevant to the motor power supply.(J9 & J10 links closed)

If J9 & J10 links are open, then this output will source power through (Pins 23 & 11 25way D-sub or pins 20 & 21 PCB J13)

## 7.3 FACTORY CONFIGURATION OF OPERATING PARAMETERS

To configure the variable parameters of Steptronic, a configuration display unit is required to set and view the parameter values. Steptronic can be configured when the mode is switched from RUN to Configure: (Pin 17, 25w D-sub)

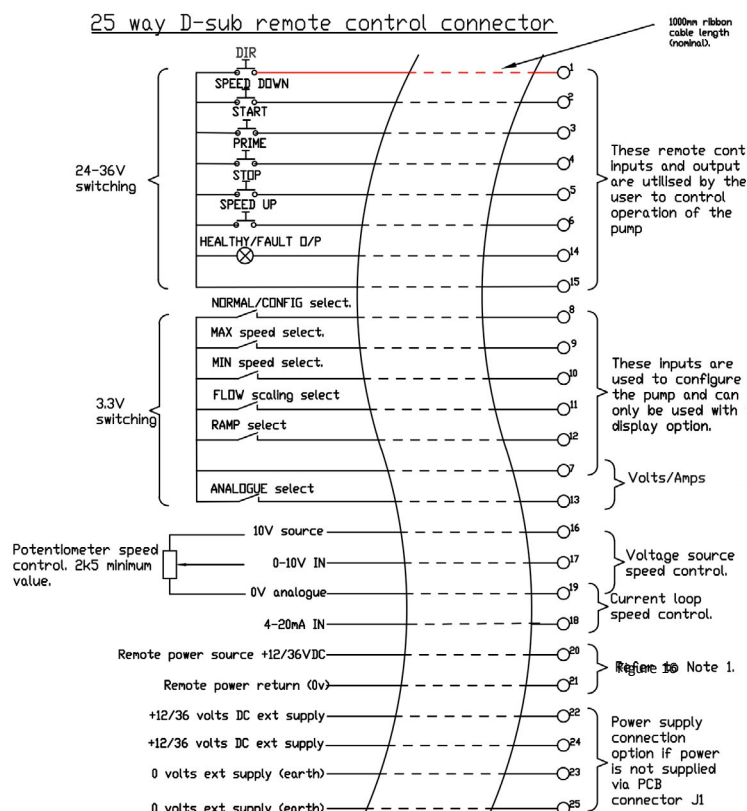

Figure 17. Wiring the ribbon cable on panel mounted units



When the configuration display is connected, the display will show:-

- A) Stopped/ Running
- B) Speed demand (RPM)
- C) Flow rate (mL/Min)

Only when the pump is stopped will switching this input low change the pump from Run to Configuration mode. The display will confirm this action by displaying (PROG).

### 7.3.1 Selection of Analogue mode:

(Pin 7, 25w D-sub)

Switching this input logically low will change the Analogue speed control input from 0-10V to 4-20mA. Analogue speed control is only available when the pump is configured to Analogue speed control mode.

### 7.3.2 Maximum speed:

Switching this input low allows the Maximum speed setting of the pump to be configured. The display will show (MAX) and the current set maximum speed value in RPM.

Switch the User "Speed up" (Pin 16, 25w D-sub) or "Speed down" (Pin 14, 25w D-sub) inputs to change the value of Max speed.

The maximum value allowed is 409.6RPM and the minimum value of Max speed will always be at least 2RPM higher than the set Min speed value.

Switch the Max speed input back to logical high to record the set value and return the display back to (PROG).

### 7.3.3 Minimum speed:

Switching this input low allows the Minimum speed setting of the pump to be configured. The display will show (MIN) and the current set minimum speed value in RPM.

Switch the User "Speed up" (Pin 16, 25w D-sub) or "Speed down" (Pin 14, 25w D-sub) inputs to change the value of Min speed.

The minimum value allowed is 0.000RPM and the maximum value of Min speed will always be at least 2RPM lower than the set Max speed value.

Switch the Min speed input back to logical high to record the set value and return the display back to (PROG).

### 7.3.4 Flow

(Pin 6, 25w D-sub)

Switching this input low allows the Flow rate of the display to be calibrated to show a flow rate that is relative and synchronous with the pump speed.

The display will show (FLOW) + XXX.XmL/Min + "The set speed" (RPM).

Assuming that calibration has been measured at the set RPM, the flow-rate can now be changed to match the measured value.

To change the set value: - Switch the User "Speed up" (Pin 16, 25w D-sub) or "Speed down" (Pin 14, 25w D-sub) inputs to change the value of flow.

Switch the Flow input back to logical high to record the set value and return the display back to (PROG).

**The displayed flow-rate will now be relative and synchronous with changes in RPM.**

### 7.3.5 RAMP

(Pin 19, 25w D-sub)

Switching this input low allows the pumps acceleration / deceleration value to be set. The display will show (RAMP) + X seconds. Acceleration and decelerations values are identical and cannot be separated.

The minimum value of Ramp is 1 second.

The maximum value of Ramp is 5 seconds.

Ramp rate value is relative to the entire span range of the pump (0.000RPM – 409.6RPM).

If the span range is reduced, then the Ramp timing is also reduced accordingly.

To change the set value: - Switch the User "Speed up" (Pin 16, 25w D-sub) or "Speed down" (Pin 14, 25w D-sub) inputs to change the value of ramp.

Switch the "Ramp" input back to logical high to record the set value and return the display back to (PROG).

### 7.3.6 Logical low:

Is the connection of a configuration input to an internal digital zero volts DC (Pin 4, 25w D-sub). This point of connection must be used to switch all configuration inputs.

### 7.3.7 Error displayed:

If more than one configuration input has been accidentally selected the display will report "ERROR" to demonstrate the fact. Find and remove the erroneous input to restore normal operation.

For example: Config (prog) + Flow + Ramp= ERROR.



## 8 Inspection, Maintenance and Repairs

### 8.1 Inspections

 The inspection intervals depend on the pump operating cycle.

1. Check at appropriate intervals:
  - Normal operating conditions unchanged
2. For trouble-free operation, always ensure the following:
  - No leaks
  - No unusual running noises or vibrations
  - Tube in position

### 8.2 Maintenance

 These pumps are generally maintenance free and any work should normally be limited to inspections; these may be more frequent in dust and/or hot condition.

Pump motor is lubricated for life and should not require attention. Rotor rollers are self-lubricated. Pump tubing will not last forever; establish suitable tube replacement schedule to prevent inconvenient tube failure.

The pump casing in the cased steptronic version contains no user serviceable parts and is factory sealed to confirm integrity. Pump warranty will be invalidated if the seal is broken.

 **DANGER**

#### Risk of injury due to running pump or hot parts!

- ▶ Do not carry out any repair/maintenance work on a pump in operation.
- ▶ Allow the pump to cool down completely before starting any repair work.

 **DANGER**

#### Risk of electrocution!

- ▶ Have all electrical work carried out only by qualified electricians.

#### 8.2.1 Cleaning the pump

### NOTE

#### High water pressure or spray water can damage motors!

- ▶ Do not clean motors with water
  1. Clean large-scale grime from the pump head.
  2. Rinse the tube carefully to remove chemicals

### 8.2.2 Maintenance schedule

Task	Frequency	Action
Check pump for leaks and damage	<ul style="list-style-type: none"> <li>– Before pump start up</li> <li>– Daily visual inspection</li> <li>– Scheduled intervals during operation</li> </ul>	<ul style="list-style-type: none"> <li>▶ Repair leaks and damage before operating the pump</li> <li>▶ Replace components as necessary.</li> <li>▶ Clean up any spillage.</li> </ul>
Check pump for unusual temperatures or noise in operation	<ul style="list-style-type: none"> <li>– Daily visual inspection</li> <li>– Scheduled intervals during operation</li> </ul>	<ul style="list-style-type: none"> <li>▶ Check pump and motor for damage. Replace worn components.</li> </ul>
Replace tube element	<ul style="list-style-type: none"> <li>– After inspection when required</li> <li>– When flow has dropped by 25% of original value</li> <li>– When the tube is burst/damaged</li> </ul>	<ul style="list-style-type: none"> <li>▶ Replace tube (→ 5.4.2 &amp; 5.5.2 Tube change)</li> </ul>
Check pump housing and rotor internally	<ul style="list-style-type: none"> <li>– Annually</li> <li>– On replacing the tube</li> </ul>	<ul style="list-style-type: none"> <li>▶ Worn and damaged surfaces give rise to premature tube failure</li> <li>▶ Replace worn components.</li> <li>▶ Check bearing play and function.</li> </ul>

Tab. 7 Maintenance schedule

## 8.3 Repairs

### DANGER

#### Risk of death due to electric shock!

- ▶ Have all electrical work carried out by qualified electrician only

#### 8.3.1 Preparations for dismounting

- ✓ Pump completely emptied, flushed and decontaminated
- ✓ Electrical connections disconnected
- ✓ Pump cooled down
- ✓ Auxiliary systems shut down, depressurized and emptied

### WARNING

#### Risk of injury while removing the pump components!

- ▶ Use protective equipment when carrying out any work on the pump.
- ▶ Observe manufacturer's instructions (e.g. for Motor...)

#### 8.3.2 Returning the pump to the manufacturer

- ✓ Completely emptied and decontaminated.
- ✓ Pump cooled down
- ✓ Tube removed (→ 5.4.2 & 5.5.2 Removing the tube)

#### Obtain prior authorisation before repair or return of the pump.

- ▶ Enclose a completed document of compliance when returning pumps or components to the manufacturer

Repairs	Measure for return
...at the customer's premises	<ul style="list-style-type: none"> <li>– Return the defective component to the manufacturer.</li> <li>– Decontaminate if necessary.</li> </ul>
...at the manufacturer's premises	<ul style="list-style-type: none"> <li>– Flush the pump and decontaminate it if it was used for hazardous pumped liquids.</li> </ul>
...at the manufacturer's premises for warranty repairs	<ul style="list-style-type: none"> <li>– Only in the event of hazardous pumped liquid, flush and decontaminate the pump</li> </ul>

Tab 8. Measures for return

### 8.3.3 Rebuild / Repair

-  Reinstall the components, in accordance with the marks applied.

### NOTE

#### Material damage due to unsuitable components!

- ▶ Always replace lost or damaged parts with genuine Verderflex spares.

1. Observe the following during the installation:
  - Replace worn parts with genuine spare parts.
2. Clean all parts.
3. Reassemble the pump (→ refer sectional drawing).
4. Install the pump in the system (→ 5 Installation and connection)

## 8.4 Ordering spare parts

-  For trouble-free replacement in the event of faults, we recommend keeping spare parts available on site.

- ▶ The following information is mandatory when ordering spare parts (→ Name plate ):
  - Pump model
  - Year of manufacture
  - Part number / Description of part required
  - Serial number
  - Quantity

## 9. Storing pumps and tubes



We recommend certain pre-storage actions and precautions be taken whilst pumps and their components are not in use.

Similarly, tubes and spares may be held in stock to service working pumps and their recommended storage conditions are advised.

### 9.1.1 Pre-Storage Actions

- The tube should be removed from the pump
- The pump casing should be washed out allowed to dry and any external build up of product removed.

### 9.1.2 Storage Conditions

- Pumps should be stored in a dry environment, out of direct sunlight. Depending on these conditions, it may be advisable to place a moisture-absorbing product, such as Silica gel, inside the pump's casing whilst the pump is stored.
- Tubes should be stored as supplied in their wrapper and should be stored away from direct sunlight and at room temperature.

## 10. Troubleshooting

### 10.1 Pump malfunctions

If malfunctions occur which are not specified in the following table or cannot be traced back to the specified causes, please consult the manufacturer.

Possible malfunctions are identified and respective cause and remedy are listed in the table.

Problem	Cause	Solution	
Low Flow / low discharge pressure	Ratio of inner diameter / wall thickness too large for the application (tube too 'soft')	Use thicker wall thickness tube with the same inner diameter. This may require a different tube clamp or pump	
		Run Pump slower with larger inner diameter tube	
	Viscosity too high	Run the pump slower	
	Suction lift too high, resulting in tube not fully returning to fully round		Use thicker wall thickness tube with the same inner diameter. This may require a different tube clamp or pump.
			Use a bigger pump running slower
	Wall thickness does not match the specifications of the tube clamp used.	Purchase appropriate tube clamp or change wall thickness	
	Discharge pressure too high	Poor flow is caused by excessive backflow, reduce discharge pressure	
Using non-standard tubing	Use Verderflex approved genuine tubing		
Tube walks through pump head	Tube outer diameter too small for the pump head used	Adjust tube clamp tension / check tube clamp installed	
		Use tube with correct outer diameter.	

Tab. 9 Pump troubleshooting list

## 11. Appendix

### 11.1 Technical Specifications

#### 11.1.1 Pump Specifications

Size	Value
Max. delivery pressure	2 bar
<b>IP Rating</b> Standard Cased Version: Open Frame Version: Optional IP66 Casing:	IP31 IP00 IP66
Max. configurable speed Min. speed	409.6 rpm 0 rpm
Dimensions	Refer datasheet for models
Typical audible noise level (No pump head)	50dBA @1meter

Tab. 10 Pump Specifications– Steptronic

#### 11.1.2 Ambient conditions

Operation under any other ambient condition would require approval from the manufacturer

#### Operating conditions

- Ambient temperature  $-5\text{ }^{\circ}\text{C}$  to  $+45\text{ }^{\circ}\text{C}$
- Up to  $30\text{ }^{\circ}\text{C}$ : 80% RH (Non condensing).  
 $30\text{ }^{\circ}\text{C}$  -  $45\text{ }^{\circ}\text{C}$  reducing linearly to 30% RH (Non condensing)
- Setup height above sea level  $\leq 1000\text{m}$  / 3000 ft above sea level

#### Storage conditions

- Ambient temperature  $+18\text{ }^{\circ}\text{C}$  to  $+65\text{ }^{\circ}\text{C}$
- Relative humidity – long—term  $\leq 80\%$

Maximum Motor Temperature Rise:  $80\text{ }^{\circ}\text{C}$

#### 11.1.3 Power Supply

##### Motor supply operating voltage range:

- Minimum 12Vdc
- Nominal 24Vdc
- Maximum 36Vdc

##### Control circuit operating voltage range

- Minimum 12Vdc
- Maximum 36Vdc

##### Drive Power supply:

- 40VA (SMPS)
- 35VA Linear

#### 11.1.4 Tube Variants



For safety reasons we do not recommend pumping liquids greater than  $80\text{ }^{\circ}\text{C}$  ( $176\text{ }^{\circ}\text{F}$ ). The following criteria are important when selecting a tube:

- Chemical resistance
- Food grade quality
- Tube life
- Physical compatibility

Type	Feature
Verderprene	General purpose tubing
Silicone	High sterility tubing
Tygon	Chemical fluids tubing
Viton	Aggressive chemical tubing

Tab. 11 Verderflex Tube variants



## 11.2 List of Figures and Tables



### 11.2.1 List of figures

Figure 1	Name plate	3.2
Figure 2	Layout – Steptronic mini-load cased	3.4
Figure 3	Layout – Steptronic EZ head cased	3.5
Figure 4	Layout – Steptronic Mini-load panel mounted	3.6
Figure 5	Layout – Steptronic EZ head panel mounted	3.7
Figure 6	Installing tube into mini-load pump head	5.4.2
Figure 7	Installing tube clamp	5.4.3
Figure 8	Changing tube clamp	5.4.4
Figure 9	Replacing pump head	5.4.5
Figure 10	Installing a stackable ML-pump head	5.4.6
Figure 11	Installing the tube on EZ head	5.5.2
Figure 12	Replacing the pump-head EZ-head	5.5.3
Figure 13	Stacking ES-head	5.5.4
Figure 14	Backplate for cased version - standard	7.2
Figure 15	Backplate for cased version - with HMI port	7.2
Figure 16	Wiring the 25-way D-sub connection	8.0

### 11.2.2 List of tables

Table 1	Target groups	1.1
Table 2	Warnings and consequences of disregarding them	1.2
Table 3	Symbols and their meaning	1.2
Table 4	Steptronic pump head options	5.3
Table 5	25-way D-sub pin connection	5.6.1
Table 6	Models and control features available	7.1
Table 7	Maintenance schedule	9.2.2
Table 8	Measures for return	9.3.2
Table 9	Pump troubleshooting list	11.1
Table 10	Pumps specifications	12.1.1
Table 11	Tube variants	12.1.4
Table 12	Declaration of conformity according to EC Machine Directive	12.3

### 11.3 Declaration of conformity according to EC Machine Directive

<p><b>EC declaration of conformity according to machine directive, appendix II A</b></p> <p>We,                  VERDER Ltd., Unit 3 California Drive, Castleford                  hereby declare that the following machine adheres to the relevant EC directives                  detailed below</p> <p>Designation    <b>Verderflex Steptronic</b></p> <p>EC directives:</p> <ul style="list-style-type: none"> <li>• Machine Directive (2006/42/EC)</li> <li>• Low-voltage directive (2006/95/EC)</li> <li>• EMC directive (2004/108/EC)</li> </ul>		
Responsible for the documentation	VERDER Ltd. Unit 3 California Drive Castleford WF10 5QH UK	
Date: 01/ 07/ 2015	Company stamp / signature:  <b>David Sampson</b> Head of Development/Construction	Company stamp / signature:  <b>David Hoyland</b> Head of Quality

Tab. 12 Declaration of conformity according to EC Machine Directive

