

VERDERAIR PURE

The most efficient diaphragm pump

TABLE OF CONTENTS

Pump Matrix	3
Atex	4
Warnings	4
Installation	7
Operation	10
Maintenance / repair	11
Trouble shooting	17
Parts and kits	18
Exploded views	18
Dimensions and mounting	20
Performance charts	21
Technical data	23
Torque Values	25
Optional equipment	26
Customer services & guarantee	28

PUMP MATRIX

Before putting your pump in operation, check the identification plate (ID) on the pump. The ID is mentioning the year of construction, the serial number and the construction code of the pump. Use the matrix below to define the components of your pump. Make sure the wetted parts of the pump are compatible to the pumped liquid.

NOTE:

- In case of doubt, please contact your local supplier. (www.verderair.com)
- To build a pump code, please use the below coding system.

PUMP CODING VA-P			
Pump size	Housing and center section		Valve seat
	Housing	Center section	
08 : 1/4"	E : PE	E : PE	EE : PE
10 : 3/8"	G : PE conductive	G : PE conductive	GG : PE conductive
15 : 1/2"	T : PTFE	T : PTFE	TT : PTFE
25 : 1"	U : PTFE conductive	U : PTFE conductive	UU : PTFE conductive
40 : 1 1/2"			
50 : 2"			
Valve Ball	Diaphragm	Connections	Options
EP : EPDM	TO : PTFE overmolded	TN : Threaded NPT	OO : standard, no option
TF : PTFE	EO : EPDM overmolded	FD : flanged DIN	SS : stroke sensor
SS : SS316		FA : Flanged Ansi	RE : remote
CV : cylinder valve		FJ : Flanged JIS	DM : draining manual
			DP : draining pneumatical
			BS : barrier system with sensors only
			LS : leak detection, sensor only
			PD : prepared for dampener
			AP : Ansi prepared
			VS : Vertical suction

Notes:

- not all combinations are available, contact your local supplier for more info.
- Some of the mentioned pumps can be combined in 1 pump, for available combinations please check the list at page 26



EXAMPLE : VA-P25EE EE TF TO TN OO

ATEX

For use in ATEX environments, pumps in conductive plastic have to be used. All pumps made of conductive Polyethylene (pump code VA-Pxx GG) and pumps made of conductive PTFE (pump code VA-Pxx UU) are ATEX certified.  II 2G/2GDc IIC/IIIC Tx. The pumps have to be grounded following the instructions on page 8.

When using conductive diaphragms at the liquid side, no restrictions are applicable.







When using non - conductive diaphragms, the following protective measures have to be taken into account:

- Pumped liquid must be conductive or soluble in water
- Dry running have to be prevented by means of monitoring systems which are placed in the pump system

WARNINGS

The following warnings are for the setup, use, grounding, maintenance, and repair of this equipment. The exclamation point symbol alerts you to a general warning and the hazard symbol refers to procedure specific risk. When these symbols appear in the body of this manual, refer back to these warnings. Additional, product-specific warnings may be found throughout the body of this manual where applicable.

WARNING

FIRE AND EXPLOSION HAZARD

Flammable fumes, such as solvent and paint fumes, in work area can ignite or explode. To help prevent fire and explosion:

- Use equipment only in well ventilated area.
- Eliminate all ignition sources; such as pilot lights, cigarettes, portable electric lamps, and plastic drop cloths (potential static arc).
- Keep work area free of debris, including solvent, rags and gasoline.
- Do not plug or unplug power cords, or turn power or light switches on or off when flammable fumes are present.
- Ground all equipment in the work area. See grounding instructions.
- Use only grounded hoses.
- If there is static sparking or you feel a shock, stop operation immediately. Do not use equipment until you identify and correct the problem.
- Keep a working fire extinguisher in the work area.

Static charge may build up on plastic parts during cleaning and could discharge and ignite flammable materials and gases. To help prevent fire and explosion:

- Clean plastic parts in a well ventilated area.
- Do not clean with a dry cloth.

WARNING**EQUIPMENT MISUSE HAZARD**

Misuse can cause death or serious injury.

- Do not operate the unit when fatigued or under the influence of drugs or alcohol.
- Do not exceed the maximum working pressure or temperature rating of the lowest rated system component. See Technical Data in all equipment manuals.
- Use fluids and solvents that are compatible with equipment wetted parts. See Technical Data in all equipment manuals. Read fluid and solvent manufacturer's warnings. For complete information about your material, request MSDS from distributor or retailer.
- Do not leave the work area while equipment is energized or under pressure. Turn off all equipment and follow the Pressure Relief Procedure in this manual when equipment is not in use.
- Check equipment daily. Repair or replace worn or damaged parts immediately with genuine manufacturer's replacement parts only.
- Do not alter or modify equipment.
- Use equipment only for its intended purpose. Call your distributor for information.
- Route hoses and cables away from traffic areas, sharp edges, moving parts, and hot surfaces.
- Do not kink or over bend hoses or use hoses to pull equipment.
- Keep children and animals away from work area.
- Comply with all applicable safety regulations.

**PRESSURIZED EQUIPMENT HAZARD**

Fluid from dispense valve, leaks, or ruptured components can splash in the eyes or on skin and cause serious injury.

- Follow Pressure Relief Procedure in this manual, when you stop the pump and before cleaning, checking, or servicing equipment.
- Tighten all fluid connections before operating the equipment.
- Check hoses, tubes, and couplings daily. Replace worn or damaged parts immediately.

**THERMAL EXPANSION HAZARD**

Fluids subjected to heat in confined spaces, including hoses, can create a rapid rise in pressure due to the thermal expansion. Over-pressurization can result in equipment rupture and serious injury.



- Open a valve to relieve the fluid expansion during heating.
- Replace hoses proactively at regular intervals based on your operating conditions.



WARNING**PLASTIC PARTS CLEANING SOLVENT HAZARD**

Use only compatible water-based solvents to clean plastic structural or pressure-containing parts. Many solvents can degrade plastic parts and cause them to fail, which could cause serious injury or property damage. See Technical Data in this and all other equipment instruction manuals. Read fluid and solvent manufacturer's warnings.

**TOXIC FLUID OR FUMES HAZARD**

Toxic fluids or fumes can cause serious injury or death if splashed in the eyes or on skin, inhaled, or swallowed.



- Read MSDS's to know the specific hazards of the fluids you are using.
- Route exhaust away from work area. If diaphragm ruptures, fluid may be exhausted with air.
- Store hazardous fluid in approved containers, and dispose of it according to applicable guidelines.
- Always wear impervious gloves when cleaning equipment.

**BURN HAZARD**

Equipment surfaces and fluid that's heated can become very hot during operation. To avoid severe burns:

- Do not touch hot fluid or equipment.
- Wait until equipment/fluid has cooled completely.

**PERSONAL PROTECTIVE EQUIPMENT**

You must wear appropriate protective equipment when operating, servicing, or when in the operating area of the equipment to help protect you from serious injury, including eye injury, inhalation of toxic fumes, burns, and hearing loss.



This equipment includes but is not limited to:

- Protective eyewear, gloves, and hearing protection
- Protective clothing

INSTALLATION

**PLEASE CHECK THE ADDITIONAL DELIVERED
EXPLODED VIEW FOR ALL POSITION NUMBERS**

Tighten Fasteners Before Setup

Before using the pump for the first time, check and retorque the housing bolts (23). Liquid valve plugs (09) and the center housing plug (04) have to be checked too. Also after the first day of operation, after periods of important temperature

fluctuations, after transport, after dismantling of the pump and after periods when the pump hasn't been working the stops, plugs and housing bolts have to be checked. For the housing bolts please use the torque values as mentioned on page 25.

Recommended installation drawing

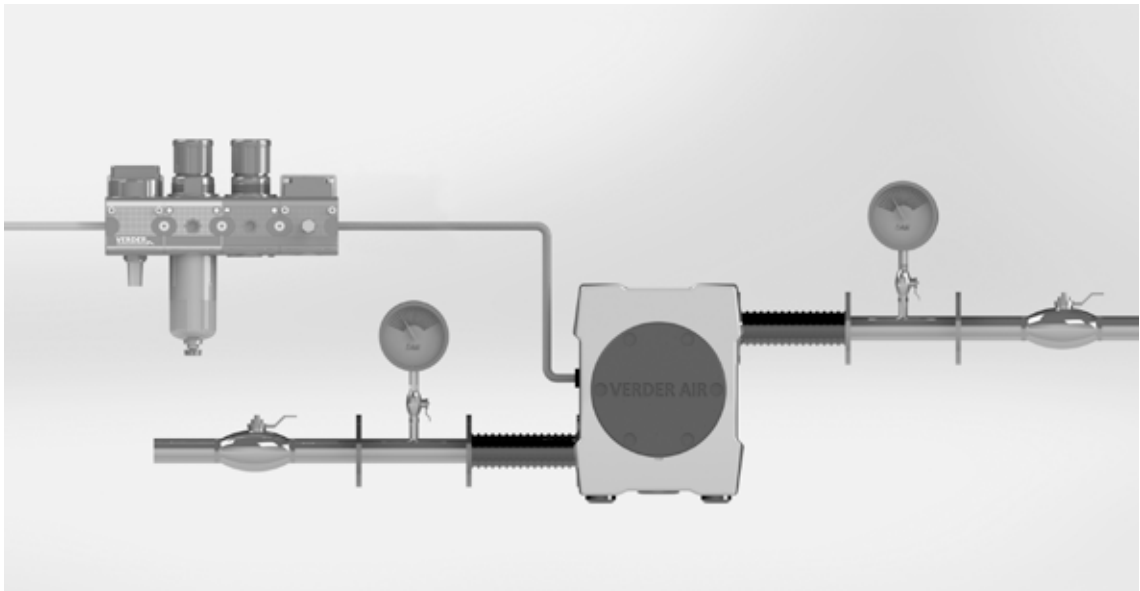

Mounting

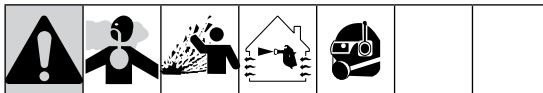

- The pump exhaust air may contain contaminants. Ventilate to a remote area. See Air Exhaust Ventilation on page 9.
- Never move or lift a pump under pressure. If dropped, the fluid section may rupture. Always follow the Pressure Relief Procedure on page 10 before moving or lifting the pump.

1. Be sure the mounting surface can support the weight of the pump, hoses and accessories, as well as the stress caused during operation.
2. For ease of operation and service, mount the pump so air inlet, fluid inlet and fluid outlet ports are easy accessible.
3. All VA-P pumps are supplied with adjustable feet.

Grounding

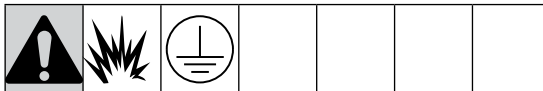

The equipment must be grounded. Grounding reduces the risk of static and electric shock by providing an escape wire for the electrical current due to static build up or in event of a short circuit. In the centre housing of electrical conductive pumps (pump code VA-Pxx GG and VA-Pxx UU) a grounding connection is included.

Check your system electrical continuity after the initial installation. Set up a regular schedule for checking continuity to be sure proper grounding is maintained.

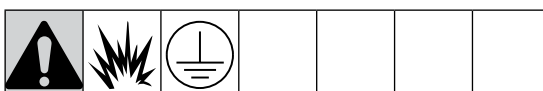

Only pumps made from conductive material are having a grounding connection. Standard PE and PTFE pumps are **not** conductive. **Never** use a non-conductive pump with non-conductive flammable fluids. Follow your local fire codes. When pumping flammable fluids, **always** ground the entire fluid system as described.

Air Line

See recommended installation drawing on page 7.

1. Install an air regulator and gauge. Set pressure of the driving air should be limited to the pressure required to run the pump on the desired working point. Setting the pressure too high will cause higher wear of the pump and will increase the compressed air consumption. The fluid stall pressure will be the same as the setting of the air regulator.
2. If the air regulator do not have a bleed off function to relieve trapped air, or the air regulator is not placed close to the pump, locate a bleed-type master air-valve close to the pump. Be sure the valve is easily accessible from the pump.



Trapped air can cause the pump to cycle unexpectedly, which could result in serious injury from splashing.

3. A Throttle valve can be used to regulate the flow rate of compressed air to the pump. By using a throttle valve it is possible to regulate the pump speed even at the lower end of the curves.
4. Install a grounded, flexible air hose between the accessories and the pump air inlet. The inner diameter of the hose have to be the same diameter of the air connection of the pump or bigger.

Air Exhaust Ventilation



Do not restrict the air exhaust port. Excessive exhaust restriction can cause erratic pump operation. At a diaphragm rupture, it is possible the pumped liquid will escape through the muffler. To prevent this, the optional diaphragm monitoring and barrier chamber can be used. Another possibility is to remote the air exhaust to a safe environment.

Fluid suction line

1. A shut off valve should be installed just before the pump to isolate the pump from the system for maintenance and installation.
2. Always use a flexible connection to avoid vibrations being brought into the piping system.
3. Use a suction line which can stand vacuum. By the pumping action, vacuum will be created at the suction side of the pump.
4. The inner diameter of the hose should be equal to the connection diameter of the pump.
5. If the inlet pressure to the pump is more than 25% of the outlet working pressure, the ball check valves will not close fast enough, resulting in inefficient pump operation and is a possible cause of noise.
6. Inlet pressure greater than 1 bar (15 PSI), diaphragm life will be shortened.

Fluid outlet line

1. A shut off valve should be installed just after the pump to isolate the pump from the system for maintenance and installation. A drain valve should be installed to relief the pressure of the pump before starting maintenance work at the pump.
2. Always use a flexible connection to avoid vibrations being brought into the piping system.

Fluid inlet and outlet ports

1. VA-P series of pump are having the suction and discharge connections integrated in the centre block. Both connections possibilities: horizontal and vertical are always available. VA-P pumps are delivered as standard with the horizontal connections open and the vertical connections plugged. See figure 2.
2. By rotating the center housing 180° and by changing the position of the centre plug, other porting combinations are possible :

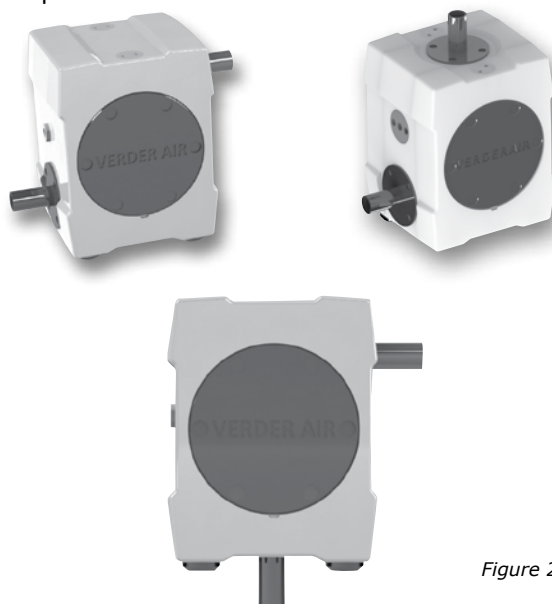

Figure 2

Installation remarks

1. VA-P pumps must be installed load free to avoid possible damage of pumps and/or installation.
2. VA-P pumps will be delivered with blind plugs to prevent dust or other materials to enter the pump. Those plugs have to be removed before installing the pump!
3. As UV – radiation can damage Polyethylene. This must taken in account by installing VA-P pumps made out of Polyethylene. (pump codes VA-Pxx EE and VA-Pxx GG)
4. The air-valves used in VA-P pumps are manufactured with tight tolerances. They should be used with clean, dry and oil-free compressed air. If the quality of the compressed air at the place where the pump is installed is not optimal, it is possible to install a dryer and/or a water separator. Please contact your distributor for more detailed information.

5. VA-P pumps are dry self-priming. So they don't need to be filled before first use. The figures of the possible suction heights can be found in the technical information. (see page 23).
6. VA-P pumps will building up pressure at the liquid side up to the pressure set on the compressed air-inlet of the pump. If this pressure is higher than the rated pressure of the discharge line, a pressure relief valve or another pressure safety equipment should be installed at the discharge side of the pump.
7. VA-P pumps can stall against a closed discharge line without damage. The pump will stop working when the pressure at the liquid side of the diaphragms is equal (or higher) then the compressed air pressure at the air-side of the diaphragm. As soon the pressure at the liquid side will drop below the compressed air pressure, the pump will restart automatically.

OPERATION

Pressure relief procedure



Trapped air can cause the pump to cycle unexpectedly, which could result in serious injury from splashing.

1. Shut off the air supply to the pump.
2. Open the dispensing valve, if used.
3. Open the fluid drain valve to relieve fluid pressure. Have a container ready to catch the drainage.

Flush pump before first use

The pump was tested before leaving the factory. Residue of the testing water can be left in the pump. To avoid contamination, flush the pump before first use.

Starting and adjusting the pump

1. Be sure the pump is properly grounded. See page 8 for proper **grounding**.
2. Check fittings to be sure they are tight. Tighten fluid inlet and outlet fittings securely.
3. Place the suction tube (if used) in fluid to be pumped.

NOTE: If fluid inlet pressure to the pump is more than 25% of outlet working pressure, the ball check valves will not close fast enough, resulting in inefficient pump operation.

4. Place the end of the fluid hose into an appropriate container.
5. Close the fluid drain valve.
6. Back out the air regulator knob, and open all bleed-type master air valves.
8. Slowly increase air pressure with the air regulator until the pump starts to cycle. Allow the pump to cycle slowly until all air is pushed out of the lines and the pump is primed. Trapped air can cause the pump to cycle unexpectedly, which could result in serious injury from splashing.
9. If you are flushing, run the pump long enough to thoroughly clean the pump and hoses.
10. Close the bleed-type master air valve.

Pump shutdown

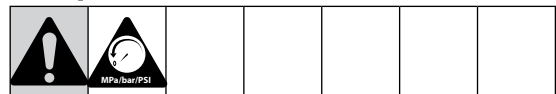

At the end of the work shift and before you check, adjust, clean or repair the system, follow **Pressure Relief Procedure**, in the left column here.

Special precautions

1. When medium is left in the pump chambers, this can generate chemical reactions when pumping another fluid. Always flush pumps with a neutral fluid before changing from medium.
2. Take care liquids left in the pump chamber can't freeze, this can damage the pump.
3. It is possible to run the pumps on nitrogen gas instead of compressed air. Take care about sufficient ventilation around the pump as the exhaust of the pump will put nitrogen gas in the atmosphere.
4. Using the pump submerged: It is necessary to connect the air outlet of the pump to the atmosphere by using a flexible hose, to prevent liquid to enter the air side of the pump. Take in consideration, all external parts of the pump must be 100% resistance to the medium where the pump is placed in. Special care have to been taken the pump is standing 100% vertical and can't start to float in all circumstances.
5. In case of big changes in temperature while operating, it is necessary to control the tension on the bolts carefully. Sudden big temperature shocks can cause over or under tightening of the pump and will lead to leaks and/or damage the pump.

MAINTENANCE / REPAIR**Flushing and storage**

Flush the pump often enough to prevent the fluid you are pumping from drying or freezing in the pump and damaging it. Always flush the pump and follow the Pressure relief Procedure on page 10 before storing it for any length of time. Use a compatible flushing agent.

Tightening Threaded connections

Before each use, check all hoses for wear or damage and replace as necessary. Check to be sure all threaded connections are tight and leak-free. Tighten and retorque the pump if necessary. Use torque values on page 25.

Preventive maintenance schedule

Establish a preventive maintenance schedule, based on the pump's service history. This is especially important for prevention of spills or leakage due to diaphragm failure.

Disassembly

IMPORTANT:

- **Follow the Pressure Relief Procedure at page 10 before starting to work at the pump !**
- **After a diaphragm rupture always make sure no liquid is left at the air side of the pump. Especially the muffler (07) have to be checked before opening the pump.**

The fluid side of the complete range of VA-P pumps are built together the same way. The only difference are the number of assembly (23) pins used. For the VA-P08 and VA-P10 both the side housings (02) are identical. The other sizes are having different right and left side housings (02 and 03).

The center section has the same built up for VA-P15 to VA-P50. The air valves for the VA-P08 and the VA-P10 are not having an air valve shaft. On those pumps the diaphragm shaft (19) is also used as piston shaft. Due to this the VA-P08 and VA-P10 are not having diaphragm shaft o-rings and diaphragm shaft bearings (20) mounted in the centre housing.

Every Verderair Pure is delivered with a AV (Air Valve) tool (Figure 3a) which has on one side pins to disassemble the air valve (27) and the opposite side can be used to push out the outer part of air valve from the center housing.

Special tools for unscrewing the liquid plugs (09) and the center housing plug (04) can be purchased separately (Figure 3b).



Figure 3a: AV Tools



Figure 3b: Set of 4 plug tools

Disassembly of the valve seats and valve balls (or cylindrical valves).

To have access to the valve seats and balls you do not need to disassemble the pump. Unscrew the liquid plug (09) at the top of the side housing (02-03) (see Figure 4). Take out the spacer (13) and the valve ball

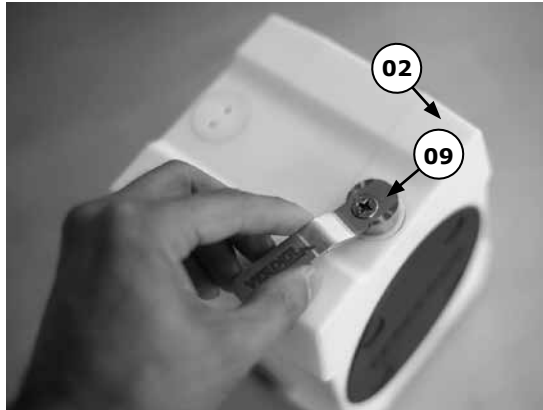

Figure 4

(11) or the cylindrical valve (10). Remove the valve seat (12) (see Figure 5). For the suction side you can work exact the

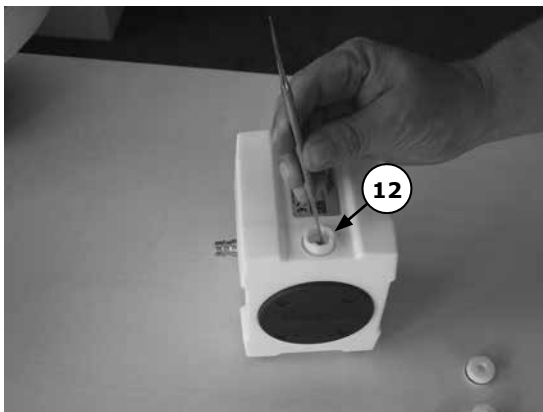

Figure 5

same way, except you have to remove first the valve seat (12) before you have access to the valve ball (11) or the cylindrical valve (10).

Disassembly of the side housings.

Remove the covers (08) of the side housings (02-03) by pushing gently a screw driver in the opening of the side housing (see Figure 6).

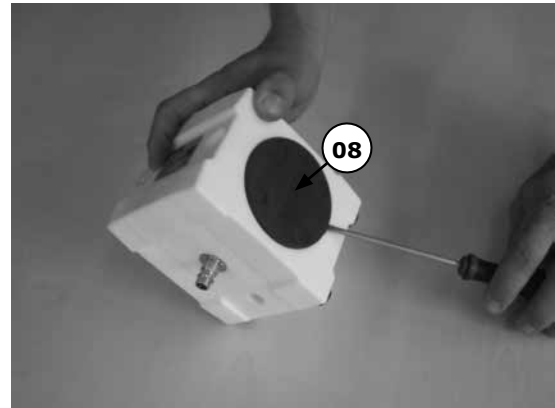

Figure 6

Unscrew the bolts on the assembly pins (23) on one side using a socket wrench. Remove the washers and the spring washers, then remove the side housing (02-03). Take care not to damage the sealing surfaces in contact with the diaphragms. Remove the assembly pins from the other side housing and remove the second side housing. Unscrew the valve stop screws and remove the valve stop (15) (see Figure 7). Remove the housing o-rings (22)



Figure 7

(see Figure 8).

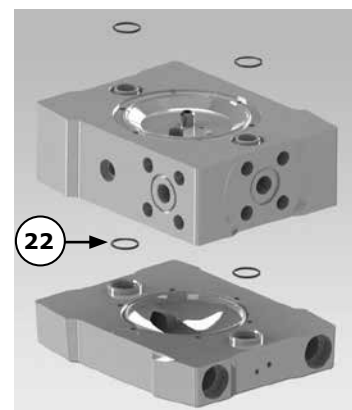

Figure 8

Disassembly of the diaphragms and diaphragm shaft.

Unscrew one diaphragm (17) (left turning) of the diaphragm shaft (19*).

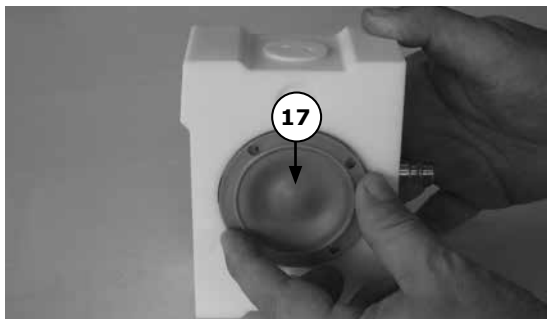

Figure 9

Pull the diaphragm shaft (19*) with the second diaphragm out of the centre housing (01). Unscrew the second diaphragm from the shaft.

* For VA-P8 and 10, part of the air-valve (27).

Disassembly of the centre housing.

For VA-P15 up to VA-P50 (not for VA-P8 and VA-P10). Remove carefully the diaphragm shaft bearings and o-rings (20) from their grooves in the centre housing. (If disassembled they need to be replaced!) Take care not to damage the edges of the grooves (see Figure 10).

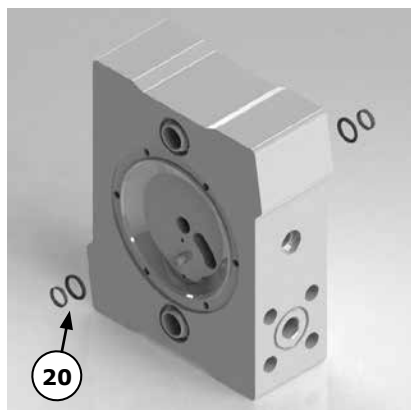

Figure 10

Unscrew the muffler (07) and the air inlet connector (05).

For unscrewing the center housing plug (04) the special plug tool (see figure 3b) can be used.

Unscrew both end caps of the air valve (27) by using the AV tool (see Figure 11)

Push out the main-valve and the air valve shaft (air valve shaft not for VA-P08 and VA-P10). Push out the air-valve housing.

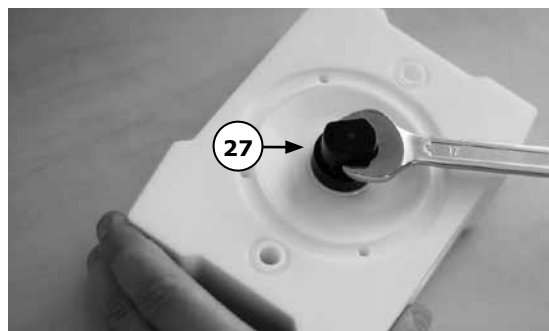

Figure 11

Assembly

Before starting to assemble please check all parts on possible damages. Especially the sealing area of the diaphragms have to be free from scratches (see Figure 12).



Figure 12

Assembly of the centre housing.

Remove the end caps, the main-valve and the air valve shaft out of the the air-valve (27). Screw one end cap flush into the centre housing (01) by using the AV tool (see Figure 11). Put 1 off the six air-valves housing o-rings part of (27) into the end cap.

Push the air-valve housing in the centre housing until it touches the end cap. Be sure the 4 air valve-housing o-rings are kept in their seat. Push the main-valve and the air valve shaft (air valve shaft not for VA-P08 and VA-P10) in the centre housing.

Put the last air-valve housing o-ring on top of it and screw the second end cap flush with the centre housing using the AV tool (see Figure 11).

Place o-ring (29) around housing plug (04) and screw in the bottom connection (for standard pumps) of the centre housing (01). Screw the muffler (07) and the air inlet connector (05) into the centre housing.>>

For VA-P15 to VA-P50 only :
put the diaphragm shaft o-rings (20) in the groove of the centre housing, by forming them as kidney's with locking ring pliers (see Figure 13).

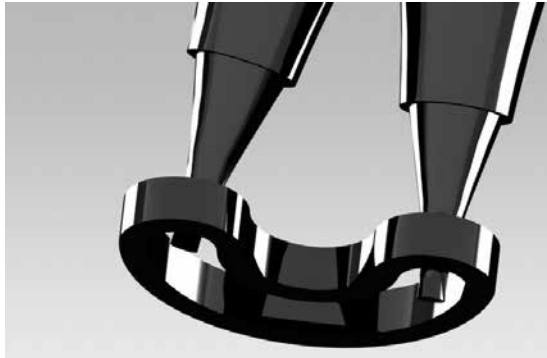

Figure 13

Push them into the groove with a round tool. On the same way the diaphragm shaft bearings can be placed in the groove.

Assembly of the diaphragms and diaphragm shaft.

Screw the diaphragm shaft screws (18) into the diaphragms and tighten. Screw one diaphragm (17) completely into the diaphragm shaft (19) (see Figure 14).



Figure 14

Push the shaft in the centre housing (1) and screw the second diaphragm (17) completely into the shaft(19) (see Figure 15).



Figure 15

Adjust, when necessary, the position of the holes for the assembly pins by turning one of the diaphragms a little backwards.

Assembly of the side housings.

Push side housing o-rings (22) into the side housings (02-03) (see Figure 16).

Push the valve stops (15) into the seats and lock them with the valve stop screws (see Figure 7). Push the assembly pins (23) through one of the side housings.

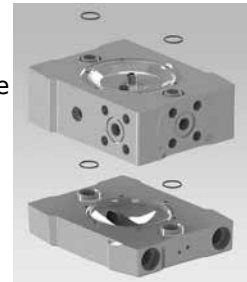

Figure 16

NOTE: do not forget to use the washers and the spring washers! Please check figure 18 for the correct positioning of the spring washers. Push the centre housing (01) over the assembly pins and finally push the second side housing over the assembly pins (see Figure 19).

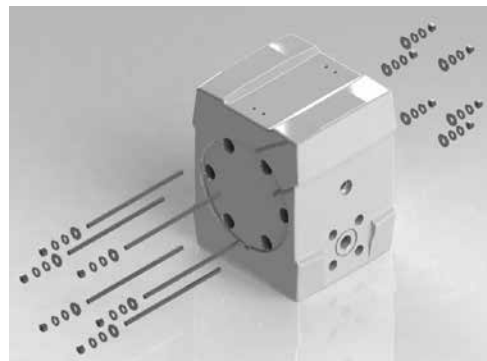

Figure 17

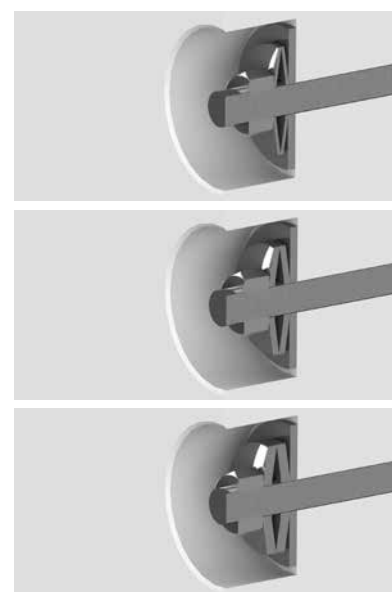

Figure 18



Figure 19

Put the washers and the spring washers on the assembly pins and put the bolts on. Fasten the bolts crosswise up to the torque values as mentioned on page 25. Push the side housings caps (08) on the side housings (see Figure 20).

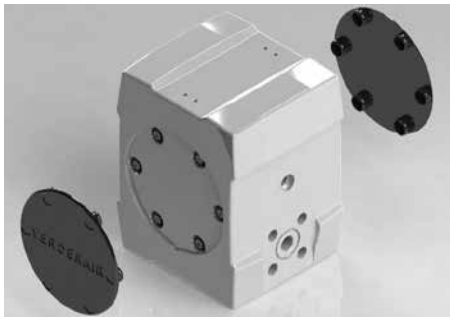

Figure 20

Assembly of the valve seats and valve balls (or cylindrical valves).

Put the valve ball (11) or the cylindrical (10) valve on the valve seat (12). Push the seat into the side housing (02-03) at the discharge side until it is touching the bottom. Push the spacer (13) into the side housing with the side hole in contact with the hole in the side housing (see Figure 21).



Figure 21

The small edge on the spacer (see Figure 22) have to fit into the recess of the side housing (see Figure 23).

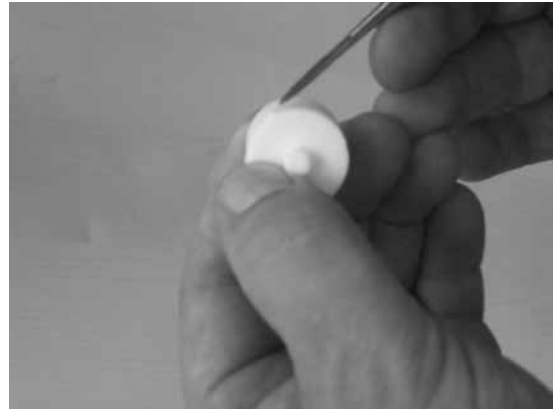

Figure 22

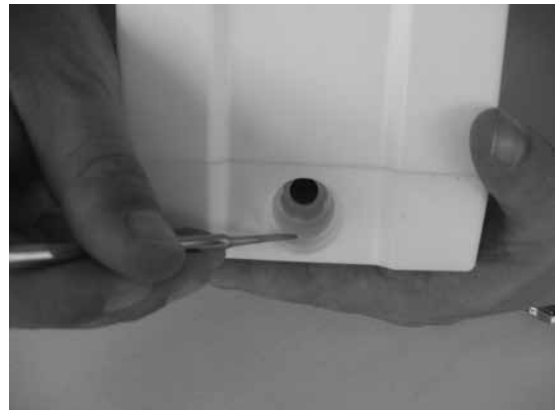

Figure 23

Push until the spacer touches the seat.

Put the liquid valve plug o-ring (14) on the liquid valve plug (09) and screw the plug flush in the housing by using the special tool. For the suction side you can work exact the same way.

Always test the pump on leakages before using it.

Problem	Cause	Solution
Pumps cycles at stall or falls to hold pressure at stall.	- Worn check valves and/or o-rings	- Replace worn parts.
Pump will not cycle, or cycle once and stops.	- Air valve is dirty. - Air valve is leaking - Air valve is blocked - Check if valve ball is not stuck in seat or chamber. - Icing of the muffler and/or air valve. - Not sufficient air pressure - Discharge line is closed - Suction line closed - Diaphragm rupture	- Clean or replace the air valve. Use filtered air! - Replace air valve - Replace air valve - Replace valve balls and/or seats. - Improve air quality. - Check air supply system on blockage and/or leakage. Or increase air supply. - Open valve in the discharge line and/or check on blockage. - Open valve in the suction line and/or check on blockage. - Replace the diaphragms and clean the pump.
Pumps operates erratically	- Clogged suction line - Check valves sticky or blocked. - Diaphragm rupture - Restricted exhaust - Air valve is leaking or blocked	- Check suction line - Clean or replace check valves. - Replace the diaphragms and clean the pump. - Remove restriction (check on icing!) and when necessary replace muffler. - Replace air valve
Air bubbles in fluid	- Suction line is loose - Diaphragm rupture - Suction container empty - Cavitation	- Tighten - Replace the diaphragms and clean the pump. - Fill or replace suction container - Check suction condition and adapt when necessary
Fluid in exhaust air	- Diaphragm rupture	- Replace the diaphragms and clean the pump.
Insufficient discharge pressure	- Not enough air pressure - Air supply is leaking - Check valves worn - Air valve is leaking	- Increase compressed air pressure or check if no other components are consuming too much air on the same compressed air line. - Check and repair - Replace check valves - Replace air valve
Discharge is decreasing	- Other components are consuming too much air on the same air supply line. - Air supply is reduced - Suction strainer is blocking - Discharge strainer is blocking - Medium becomes more viscous - Muffler blocked	- Increase the volume of air. - Check air supply system on blockage and/or leakage. - Clean suction strainer - Clean discharge strainer - Check why and if necessary adjust pump settings. - Clean out or replace. Check on icing!
Pump is running but not enough suction capability	- Pump is running too fast - Cavitation - Suction strainer is blocking - Suction line closed - Worn check valves - Leak in suction line and/or suction connections	- Start-up pump slow running. Once the pump is filled with liquid you can run the pump faster. - Check suction condition and adapt when necessary - Clean suction strainer - Open valve in the suction line and/or check on blockage. - Replace worn parts. - Repair and make leak tight

PART & KITS

Parts

SEE SEPERATE PARTS LIST

Kits

In case of break down, we recommend to have a spare part kit for your pump on stock.
Spare part kits contains:

Spare part kit, content	Quantity
O-ring, side housing (22)	4
Ball (11) / cylinder valve (10)	4
Diaphragm (17)	2
"O"-ring valve plug (14)	4
Shaft seal (VA-P 15 - VA-P 50), cpl. (20)	2
Muffler (07)	1
Air valve cpl. (27)	1

Please check the seperate spare parts list for the order nr. for the kit you need for your pump.

EXPLODED VIEWS

VA-P08/P10

POS. NR.	DESCRIPTION	QUANTITY NEEDED
1	CENTER HOUSING	1
2	SIDE HOUSING	2
4	CENTER HOUSING PLUG	1
5	AIR INLET CONNECTOR	1
6	STAND FEET	4
7	MUFFLER	1
8	CAP	2
9	LIQUID VALVE PLUG	4
10	CYLINDER VALVE	4
11	VALVE BALL	4
12	VALVE SEAT	4
13	SPACER	4
14	O-RING SET VALVE PLUG	1
15	VALVE STOP SET	2
17	DIAPHRAGM	2
22	O-RING SET HOUSING	1
23	ASSEMBLY PIN SET	4
27	AIR VALVE	1
29	O-RING CONNECTION	1

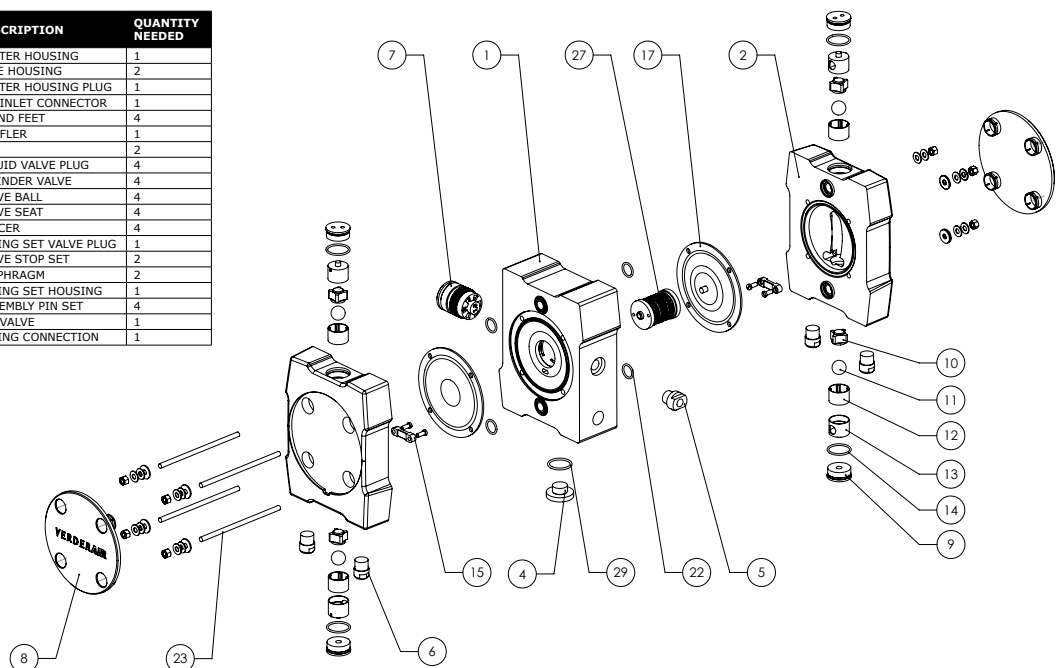

VA-P15/P25

POS. NR.	DESCRIPTION	QUANTITY NEEDED
1	CENTER HOUSING	1
2	SIDE HOUSING RIGHT	1
3	SIDE HOUSING LEFT	1
4	CENTER HOUSING PLUG	1
5	AIR INLET CONNECTOR	1
6	STAND FEET	4
7	MUFFLER	1
8	CAP	2
9	LIQUID VALVE PLUG	4
10	CYLINDER VALVE	4
11	VALVE BALL	4
12	VALVE SEAT	4
13	SPACER	4
14	O-RING SET VALVE PLUG	1
15	VALVE STOP SET	2
17	DIAPHRAGM	2
18	DIAPHRAGM SHAFT SCREW	2
19	DIAPHRAGM SHAFT	1
20	SHAFT BEARING SET	1
22	O-RING SET HOUSING	1
23	ASSEMBLY PIN SET	6
27	AIR VALVE	1
29	O-RING CONNECTION	1/3

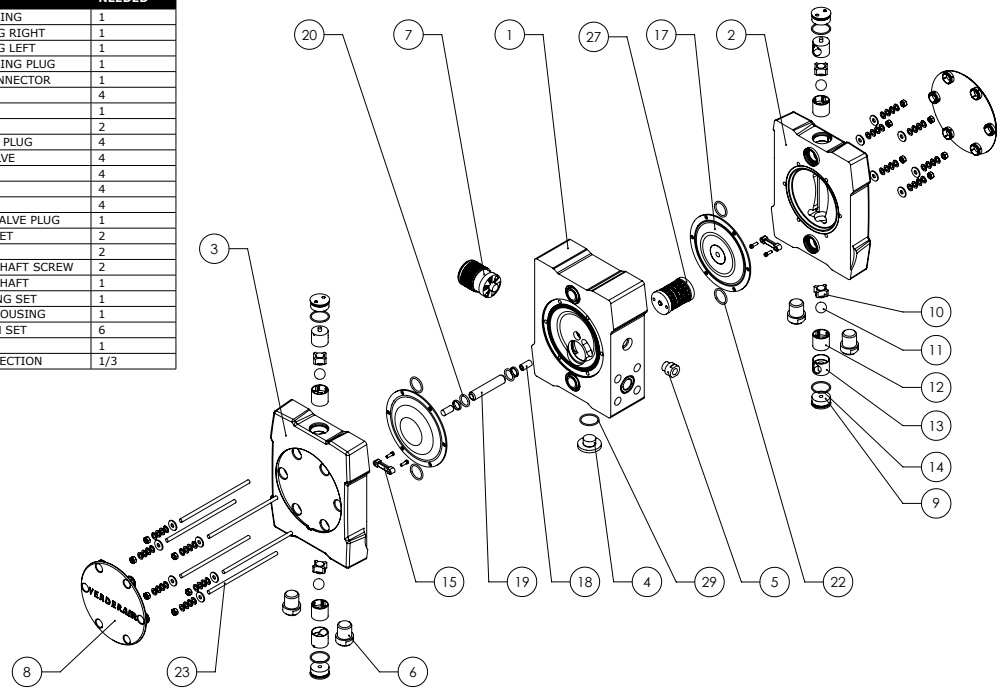

VA-P40/P50

POS. NR.	DESCRIPTION	QUANTITY NEEDED
1	CENTER HOUSING	1
2	SIDE HOUSING RIGHT	1
3	SIDE HOUSING LEFT	1
4	CENTER HOUSING PLUG	1
5	AIR INLET CONNECTOR	1
6	STAND FEET	4
7	MUFFLER	1
8	CAP	2
9	LIQUID VALVE PLUG	4
10	CYLINDER VALVE	4
11	VALVE BALL	4
12	VALVE SEAT	4
13	SPACER	4
14	O-RING SET VALVE PLUG	1
15	VALVE STOP SET	2
17	DIAPHRAGM	2
18	DIAPHRAGM SHAFT SCREW	2
19	DIAPHRAGM SHAFT	1
20	SHAFT BEARING SET	1
22	O-RING SET HOUSING	1
23	ASSEMBLY PIN SET	8
27	AIR VALVE	1
29	O-RING CONNECTION	1/3

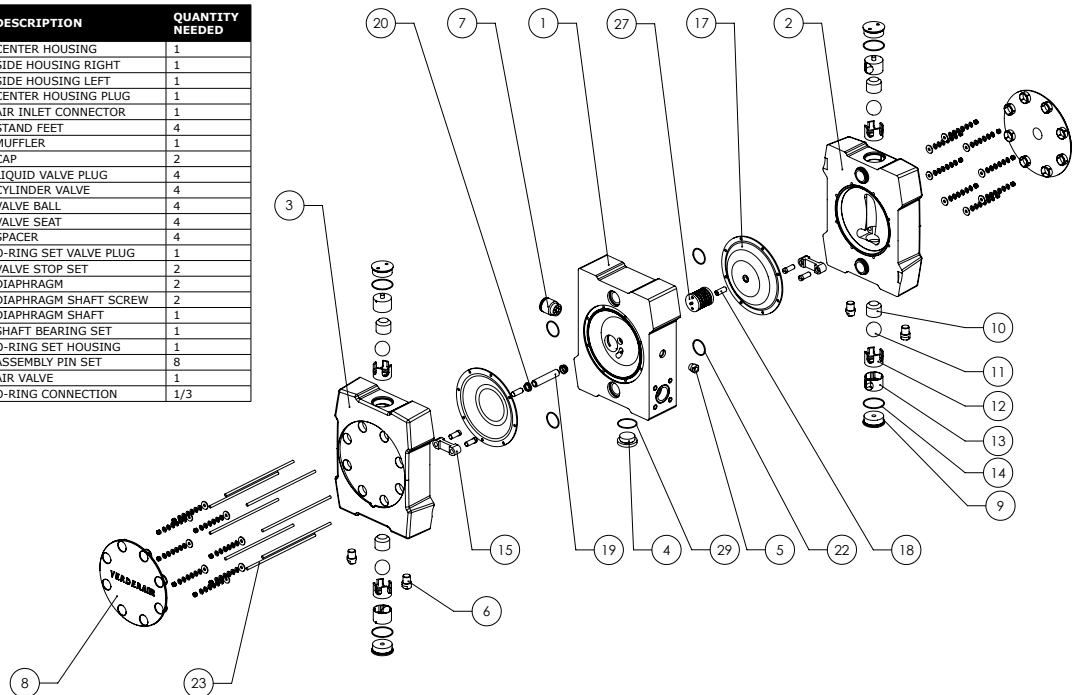

DIMENSIONS

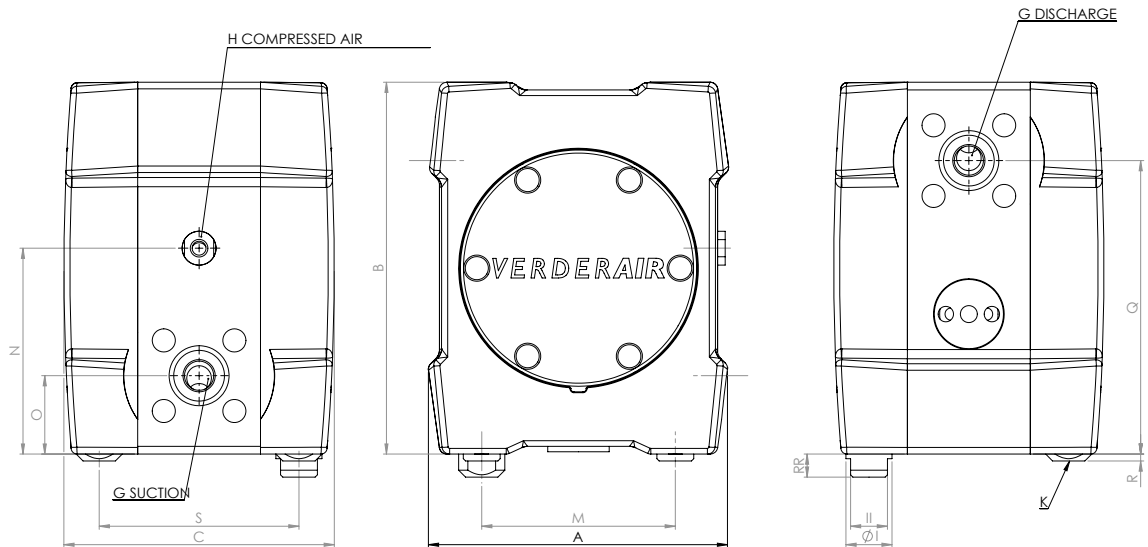

TYPE	A	B	C	G	H	I	II	K	M	N	O	Q	R	RR	S
08	99	124	109	NPT 1/4"	R 1/8	16	14	M6	69	62	19	105	2	10	80
10	132	165	126	NPT 3/8"	R 1/8	16	14	M6	85	82,5	21,5	143,5	2	10	94
15	196	242	176	NPT 1/2"	R 1/4	30	30	M8	126	134	51	191	4,5	15	120
25	250	312	239	NPT 1"	R 1/4	30	30	M8	180	137	54	258	4,5	15	155
40	329	440	320	NPT 1 1/2"	R 1/2	38	48	M10	230	220	79	361	4	25	250
50	449	550	430	NPT 2"	R 1/2	38	48	M10	310	280	94	466	4	25	330

Dimensions in mm

TYPE	A	B	C	G	H	I	J	K	M	N	O	Q	R	RR	S
08	3,90	4,88	4,29	NPT 1/4"	R 1/8	0,63	0,55	M6	2,72	2,44	0,75	4,13	0,08	0,39	3,15
10	5,20	6,50	4,96	NPT 3/8"	R 1/8	0,63	0,55	M6	3,35	3,25	0,85	5,65	0,08	0,39	3,82
15	7,72	9,53	6,93	NPT 1/2"	R 1/4	1,18	0,94	M8	4,96	5,28	2,01	7,52	0,18	0,59	5,12
25	9,84	12,28	9,41	NPT 1"	R 1/4	1,18	0,94	M8	7,09	5,39	2,13	10,16	0,18	0,59	7,28
40	12,95	17,32	12,60	NPT 1 1/2"	R 1/2	1,50	1,10	M10	9,06	8,66	3,11	14,21	0,16	0,98	10,63
50	17,68	21,65	16,93	NPT 2"	R 1/2	1,50	1,10	M10	12,20	11,02	3,70	18,35	0,16	0,98	13,39

Dimensions in inches

PERFORMANCE CHARTS

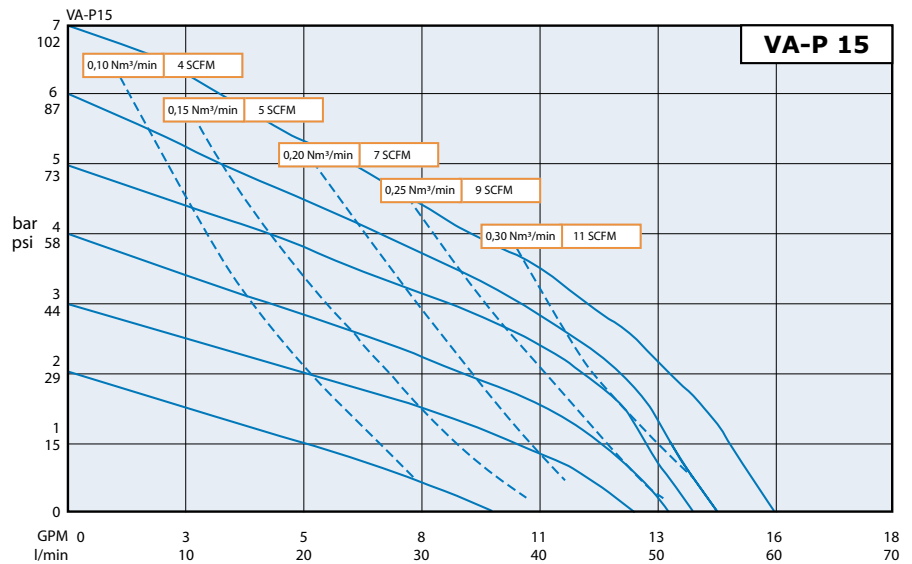
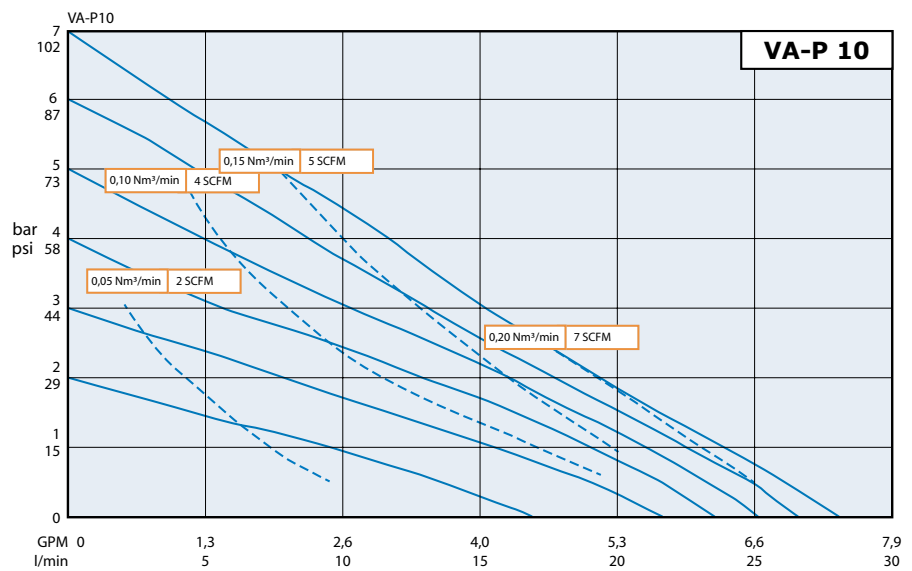
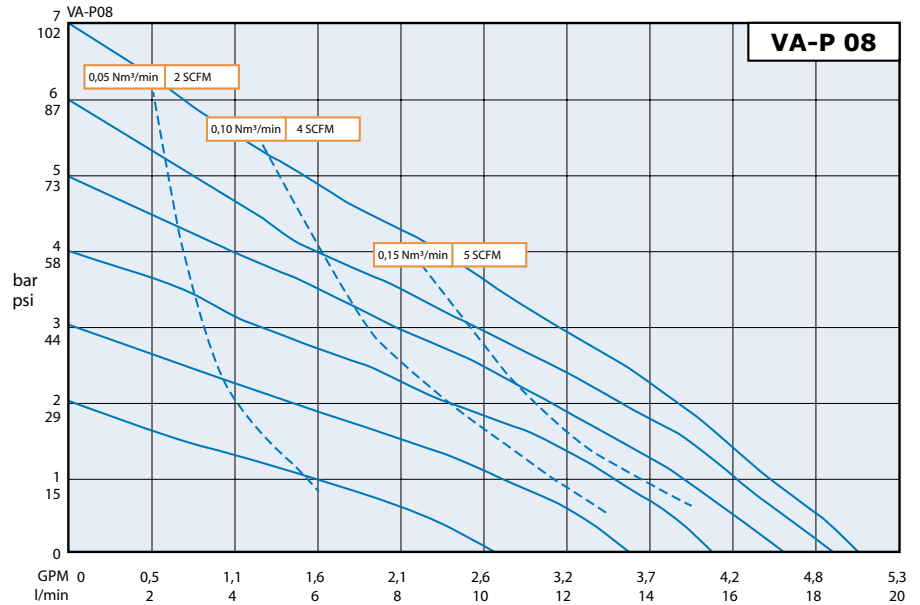

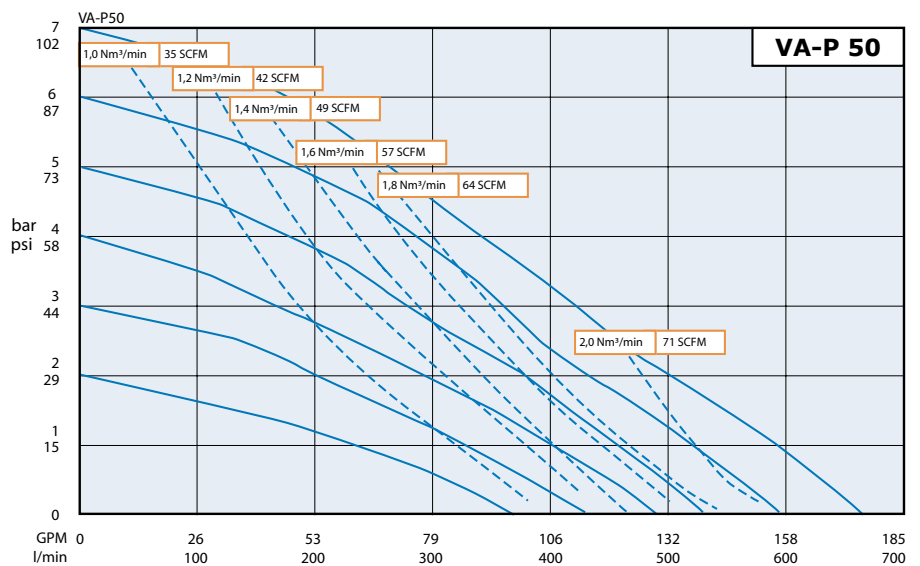
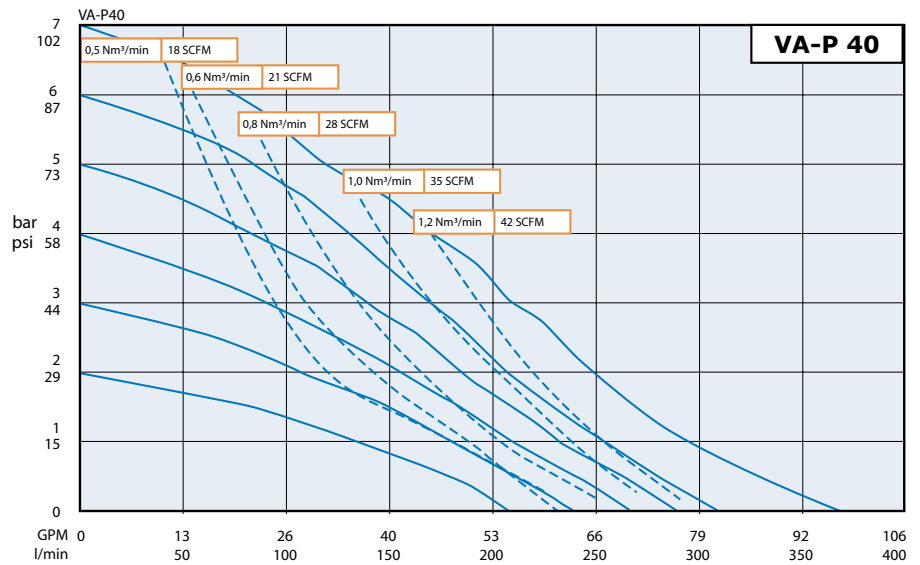
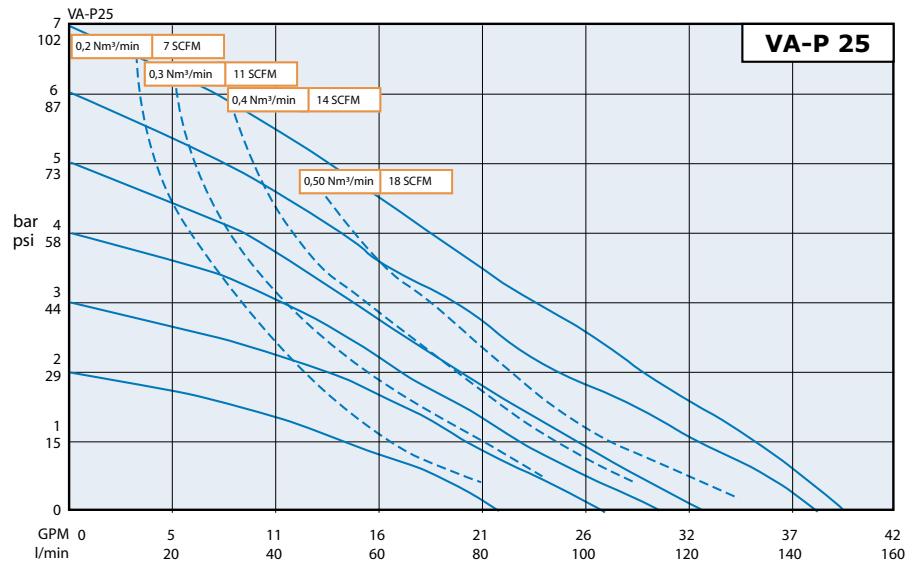

TECHNICAL DATA

ISO measurements							
Device model		VA-P08	VA-P10	VA-P15	VA-P25	VA-P40	VA-P50
Nominal port size	NPT	1/4"	3/8"	1/2"	1"	1 1/2"	2"
Air inlet	BSP	R 1/8	R 1/8	R 1/4	R 1/4	R 1/2	R 1/2
Weight (kg)	PE1000	1,1	3,6	6,9	15	39	85
	PTFE	2,5	5,1	15,4	34	87	193
	PE1000 (Cond.)	1,1	3,4	6,5	14	36	79
	PTFE (Cond.)	2,3	4,8	14,5	32	82	182
Suction lift dry (mwc)	Ball Valves	0,5	1	2	3	4	4
	Cylinder Valves	1	2	3	4	5	5
Suction lift wet (mwc)	Ball Valves	9	9	9,5	9,5	9,5	9,5
	Cylinder Valves	9	9	9,5	9,5	9,5	9,5
Max. operating pressure (Bar)		7	7	7	7	7	7
Max. operating temperature (°C)	PE1000	70	70	70	70	70	70
	PTFE	100	100	120	120	120	120
	PE1000 (Cond.)	70	70	70	70	70	70
	PTFE (Cond.)	100	100	120	120	120	120
Theoretical displacement volume (single stroke) (in liters)		0,0075	0,0215	0,1	0,34	0,98	2,6
Max. particle size of solids for pumps with ball valves (in mm)		2,2	3	4	6	9	11

TECHNICAL DATA

US measurements							
Device model		VA-P08	VA-P10	VA-P15	VA-P25	VA-P40	VA-P50
Nominal port size	NPT	1/4"	3/8"	1/2"	1"	1 1/2"	2"
Air inlet	BSP	R 1/8	R 1/8	R 1/4	R 1/4	R 1/2	R 1/2
Weight (lbs)	PE1000	2,4	7,9	15,2	33	86	187
	PTFE	5,5	11,2	34,0	75	192	425
	PE1000 (Cond.)	2,4	7,5	14,3	31	79	174
	PTFE (Cond.)	5,1	10,6	32,0	71	181	401
Suction lift dry (feet wc)	Ball Valves	1,6	3,3	6,6	9,8	13,1	13,1
	Cylinder Valves	3,3	6,6	9,8	13,1	16,4	16,4
Suction lift wet (feet wc)	Ball Valves	29,5	29,5	31,2	31,2	31,2	31,2
	Cylinder Valves	29,5	29,5	31,2	31,2	31,2	31,2
Max. operating pressure (PSI)		102	102	102	102	102	102
Max. operating temperature (°F)	PE1000	158	158	158	158	158	158
	PTFE	212	212	248	248	248	248
	PE1000 (Cond.)	158	158	158	158	158	158
	PTFE (Cond.)	212	212	248	248	248	248
Theoretical displacement volume (single stroke) (in US gallons)		0,0002	0,0006	0,0026	0,0090	0,0259	0,0687
Max. particle size of solids for pumps with ball valves (in inches)		0,09	0,12	0,16	0,24	0,35	0,43

TORQUE VALUES

Torque values for housing bolts assembly in Nm						
Device model	VA-P08	VA-P10	VA-P15	VA-P25	VA-P40	VA-P50
Housing material PE1000 and PE1000 cond.	3,0	6,0	8,5	14,0	18,0	23,0
Housing material PTFE and PTFE cond.	2,0	4,5	6,5	11,0	15,0	19,0

Torque values for housing bolts assembly in Nm					
Pulsation Dampener	PD-P10	PD-P15	PD-P25	PD-P40	PD-P50
Housing material PE1000 and PE1000 cond.	2,0	3,0	6,0	10,0	11,0
Housing material PTFE and PTFE cond.	2,0	3,0	6,0	10,0	11,0

Device model	PD-P15	PD-P25	PD-P40	PD-P50
Torque values for flange connections assembly in Nm	4,0	5,0	12,0	15,0

Torque values for housing bolts assembly in inlb						
Device model	VA-P08	VA-P10	VA-P15	VA-P25	VA-P40	VA-P50
Housing material PE1000 and PE1000 cond.	26,6	53,1	75,2	123,9	159,3	203,6
Housing material PTFE and PTFE cond.	17,7	39,8	57,5	97,4	132,8	168,2

Torque values for housing bolts assembly in inlb					
Pulsation Dampener	PD-P10	PD-P15	PD-P25	PD-P40	PD-P50
Housing material PE1000 and PE1000 cond.	17,7	26,6	53,1	88,5	97,4
Housing material PTFE and PTFE cond.	17,7	26,6	53,1	88,5	97,4

Device model	PD-P15	PD-P25	PD-P40	PD-P50
Torque values for flange connections assembly in inlb	35,4	44,3	106,2	132,8

OPTIONAL EQUIPMENT

For instructions on the use and maintenance of the below options, we are referring to the specific instruction manuals of the optional equipment.

Coding	Description
...00	Standard pump, no options
...SS	A stroke sensor is installed in the pump center part. This sensor will generate a pulse by every complete stroke of the pump. This sensor has to be connected to a controller with Namur inlet to read the pulses.
...RE	Remote operation : pump has separate connections to control the pump with an external air signal. Those pumps are not having an air valve neither a muffler installed.
...DM	Manual draining : the side housings are having a by-pass system integrated which can be manually operated to drain the pump.
...DP	Pneumatically draining : the side housings are having a by-pass system integrated which can be operated to drain the pump with a pneumatical signal
...BS	Barrier system with sensors only : the pump is equipped with a double diaphragm at each side. Between the diaphragms a neutral medium is placed. Sensors are placed in this neutral medium. When a diaphragm fails, the sensor will detect this and will create a signal which can be used to start an alarm and/or to stop the pump.
...LS	Leak detection : a capacitive sensor is installed in the muffler of the pump. This sensor will react at any liquid which comes into the muffler (in case of diaphragm rupture!). NOTE: when the pump is operated with air which is too humid, a fault signal can be generated.
...PD	Pump ready for pulsation dampener. Centre housing is mounted with the vertical connection upwards. Pulsation dampeners are having their own coding system and are not delivered mounted on the pump.
...AP	Prepared for ANSI. On VA-P15/25/40 and 50 the flanges holes are drilled following ANSI, but no inserts ! If you want the pump with ANSI flanges you need to use FA as the coding for the connections!
...VS	Pump with the vertical suction open. The centre plug is mounted on the horizontal suction connection.

Available combinations of the above mentioned options are :

Option code	Combination of options
...BL	BS + LS
...DB	DM + BS
...LD	LS + DM
...MD	DM + PD
...PB	PD + BS
...PE	PD + RE
...PL	PD + LS
...PS	PD + SS
...RS	RE + SS
...SB	SS + BS
...SL	SS + LS
...BM	PD + BS + DM
...LP	PD + LS + SS
...RM	DM + RE + PD
...DS	DM + SS + PD
...LM	LS + SS + PD + DM
...FO	PD + DP + BS + LS + SS

Note : If the combination you are looking for is not mentioned above, please contact your local supplier for more info.

CUSTOMER SERVICES & GUARANTEE

Customer services

If you require spare parts, please contact your local distributor, providing the following details:

- Pump Model
- Type
- Serial Number
- Date of First Order

Customer services

All Verder pumps are warranted to the original user against defects in workmanship or materials under normal use (rental use excluded) for two years after purchase date. This warranty does not cover failure of parts or components due to normal wear, damage or failure which in the judgement of Verder arises from misuse.

Parts determined by Verder to be defective in material or workmanship will be repaired or replaced.

Limitation of liability

To the extent allowable under applicable law, Verder's liability for consequential damages is expressly disclaimed. Verder's liability in all events is limited and shall not exceed the purchase price.

Warranty disclaimer

Verder has made an effort to illustrate and describe the products accurately; however, such illustrations and descriptions are for the sole purpose of identification and do not express or imply a warranty that the products are merchantable, or fit for a particular purpose, or that the products will necessarily conform to the illustration or descriptions.

Product suitability

Many regions, states and localities have codes and regulations governing the sale, construction, illustration and/or use of products for certain purposes, which may vary from those in neighbouring areas. While Verder attempts to assure that its products comply with such codes, it cannot guarantee compliance, and cannot be responsible for how the product is installed or used. Before purchasing and using a product, please review the product application as well as the national and local codes and regulations, and be sure that the product, installation, and use complies with them.