

Verderair VA-P40





VA-P40

VERDERAIR

Technical data VA-P40			
Nominal port size	Code NO.6	TN	1 1/2" NPT[f]
		FD	DN40
		FA	1 1/2"
		FJ	1 1/2"
Air inlet			R 1/2"
Weight [lbs]		VA-P40EE	86
		VA-P40GG	79
		VA-P40TT	192
		VA-P40UU	181
Max. operation pressure [PSI]			102
Max. operating temperature [°F]		VA-P40EE or VA-P40GG	158
		VA-P40TT or VA-P40UU	248
Max. size pumpable solids [inch]	Code NO.3	EP or TF or SS	0,35
		CV	/
Max. Suction lift dry [Feet Wc]	Code NO.3	EP or TF or SS	13,1
		CV	16,4
Max. Suction lift wet [Feet Wc]	Code NO.3	EP or TF or SS	31,2
		CV	31,2

CODE VA-P40 No.1 No.2 No.3 No.4 No.5 No.6

No.1 Housing & Center Section/ No.2 Valve seat

- EE EE = Polyethylene (PE UHMW)
-  GG GG = Conductive Polyethylene (PE UHMW)
- TT TT = PTFE
-  UU UU = Conductive PTFE

No.3 Valve balls

- EP = EPDM
- TF = PTFE
- CV = Cylinder Valve

No.4 Diaphragms

- EO = EPDM Overmolded
- TO = PTFE Overmolded

No.5 Fluid connections

- TN = NPT Threated female
- FD = Flanged DIN
- FA = Flanged Ansi
- FJ = Flanged JIS

No.6 Options

- OO = Standard, no option
- RE = Remote
- PD = Ready for Pulsation Dampener
- VS = Vertical Suction
- BS = Barrier system with Sensors only
- LS = Leak detection, Sensor only
- SS = Stroke Sensor
- DM = Draining Manual
- DP = Draining Pneumatical
- AP = ANSI Prepared

 II 2GD c II B Tx

EXAMPLE PUMP TYPE

EXAMPLE : VA-P40EE EE TF TO TN OO



Verderair VA-P40

VA-P40

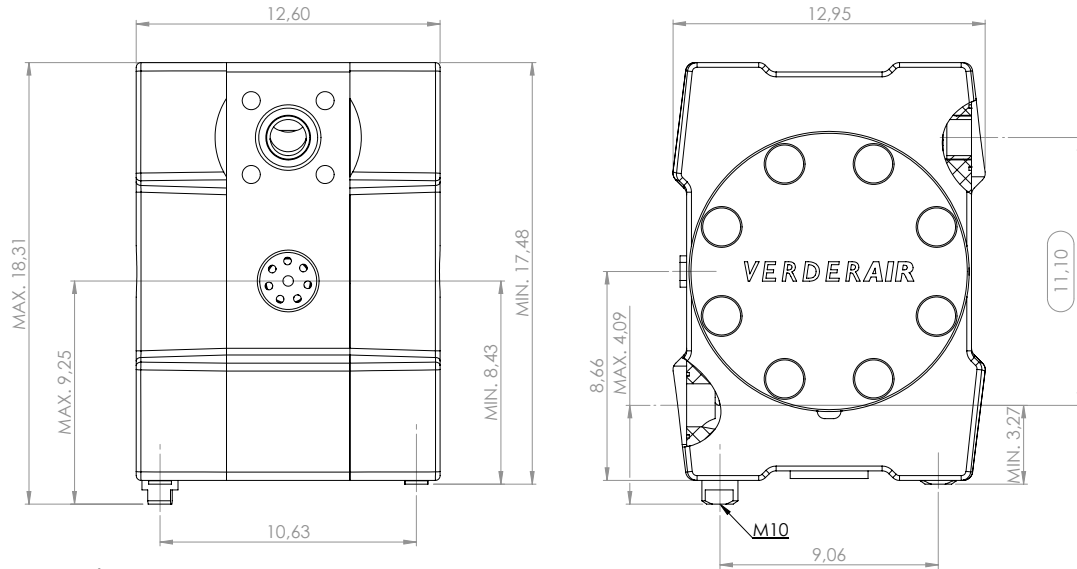

Dimensions in inches

Measured with water of 68°F

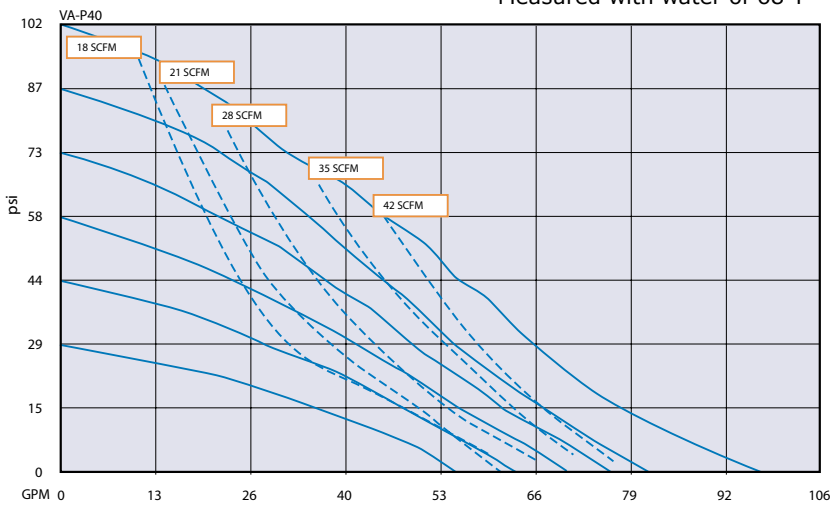

□ = Air consumption