

VERDERAIR

VA-E50



Description

The VA-E50 is an electrical driven double diaphragm pump. With the wide range of different available materials for pump body, valve seats, valve balls and diaphragms, this pump is the ideal problem solver in a wide range of applications across many industries. The VA-E50 can run in “low pulsation mode” to reduce the generated pulsations in the flow or in “transfer mode” to generate a higher flow rate.

Your benefits

- ↘ Energy efficient
- ↘ Smoother flow in “low Pulsation Mode”
- ↘ Low noise level
- ↘ Can stall against close discharge
- ↘ Can run dry without damage
- ↘ Dry self priming

Technical Data				
Weight +/- (kg)	Drive option	Fluid & air section		
	WG	AA	62	
		IA	85	
		SA	90	
		PA	58	
		CA	60	
		KA	67	
	WG	Add on for center section in SS	+ 37	
	AC5K5	Extra weight on the drive option WG above	+ 65	
	BC4K0	Extra weight on the drive option WG above	+ 50	
CC3K0/ CC2K2	Extra weight on the drive option WG above	+ 41		
AX5K5	Extra weight on the drive option WG above	+ 117		
BX4K0	Extra weight on the drive option WG above	+ 61		
CX2K2	Extra weight on the drive option WG above	+ 49		
A2xxx, B2xxx, C2xxx	Extra weight on the drive options above	+ 13		
Max. Suction lift (mwc)		Dry / Wet	5,5	
Temperature (°C)	Fluid section	Internals		
	A,S,I,K	AC	-12	82
		GE	-40*	66
		NW	-18*	82
		PP	0	66
		TF	4	104
		SP	-40*	82
		HY	-12	66
	P	All except TF	0	66
		TF	4	66
Max. Particle size (mm)		6,3		
Air connection		3/8" NPT(f)		
Air consumption (Nm³/h)		< 0,006		
Max. recommended viscosity (mPas)		20.000		

* for PVDF (code K) -12°C

VERDERAIR

VA-E50



Code VA-E50 No.1 No.2 No.3 No.4.No.5.No.6.No.7.

No.1 Fluid section

- A =Aluminium
- S =Stainless Steel
- I =Cast Iron
- P =Polypropylene
- C =Conductive PP
- K =Kynar (PVDF)

No.2 Center section

- A =Aluminium
- S =Stainless Steel

No.3 Check valve seats

- GE = Geolast
- HY =Hytril (TPE)
- KY =Kynar (PVDF)
- PP =Polypropylene
- SP =Santoprene
- SS =Stainless Steel 316

No. 4 Check valve balls

- AC = Acetal
- GE = Geolast
- HD =Stainless Steel 440C
- HY =Hytril (TPE)
- NW =Neoprene Weighted
- SP =Santoprene
- SS =Stainless Steel 316
- TF =PTFE

No. 5 Diaphragms

- GE = Geolast
- HY =Hytril (TPE)
- SP =Santoprene
- TF =PTFE/EPDM 2 piece

No. 6 Connections

- TB =Threaded BSP(f)
- TN =Threaded NPT(f)
- FE = End Flange DIN/ANSI
- FC-H =Center Flange Horizontal Outlet
- FC-V =Center Flange Vertical Outlet

No. 7 Drive options

- * WG = no gearbox -no drive

AC5K5 = Gearbox with 5,5 kW AC drive
(pump speeds: 164,145 or 130 RPM)

BC4K0 = Gearbox with 4,0 kW AC drive
(pump speeds: 105 or 87 RPM)

CC3K0 = Gearbox with 3,0 kW AC drive
(pump speeds: 73 RPM)

CC2K2 = Gearbox with 2,2 kW AC drive
(pump speeds: 54 RPM)

A25K5 = AC5K5 + integrated 240V
compressor in frame

B24K0 = BC4K0 + integrated 240V
compressor in frame

C23K0 = C23K0 + integrated 240V
compressor in frame

C22K2 = C22K2 + integrated 240V
compressor in frame

** Atex AX5K5 = Gearbox with 5,5 kW
ATEX drive (pump speeds: +/- 125 RPM)

** Atex BX4K0 = Gearbox with 4,0 kW
ATEX drive (pump speeds: +/- 90 RPM)

** Atex CX2K2 = Gearbox with 2,2 kW
ATEX drive (pump speeds: +/- 54 RPM)

Example pump type

VA-E50 AA HY AC HY TB AC5K5

NOTE not all combinations are available

* II 2 G Ex h IIB T3 Gb

** II 2 Ex h d IIB T3 Gb

VERDERAIR
VA-E50



Motor and Gearbox Code

Dimensions for Aluminium Pumps in cm

Ref.	WG	AC	A1, A2	BC	B1, B2	CC	C1, C2	AX	BX	CX	AF	BF	CF
A	50,5	50,5	50,5	50,5	50,5	50,5	50,5	50,5	50,5	50,5	50,5	50,5	50,5
B	55,6	55,6	55,6	55,6	55,6	55,6	55,6	55,6	55,6	55,6	55,6	55,6	55,6
C	59,9	59,9	59,9	59,9	59,9	59,9	59,9	59,9	59,9	59,9	59,9	59,9	59,9
D		44,2	44,2	42,2	42,2	41,1	41,1	46,7	44,7	44,7	27,2	28,2	28,2
E	5,1	5,1	5,1	5,1	5,1	5,1	5,1	5,1	5,1	5,1	5,1	5,1	5,1
F	44,5	44,5	44,5	44,5	44,5	44,5	44,5	44,5	44,5	44,5	44,5	44,5	44,5
G	21,1	87,9	87,9	81,8	81,8	77,2	77,2	105,2	88,6	86,1	111,3	95,3	95,0
H	16,0	16,0	16,0	16,0	16,0	16,0	16,0	16,0	16,0	16,0	16,0	16,0	16,0
J	37,1	103,9	103,9	97,8	97,8	93,0	93,0	121,2	104,6	102,1	127,3	111,0	111,0

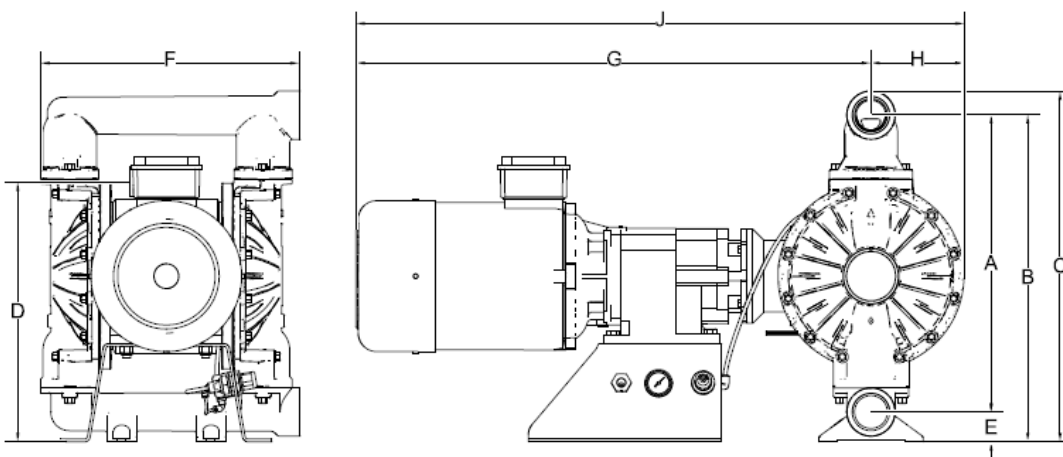

All dimensions are in cm.

All dimensions are for guidance only.

For dimensions of pumps in other materials please contact your local supplier.

VERDERAIR

VA-E50

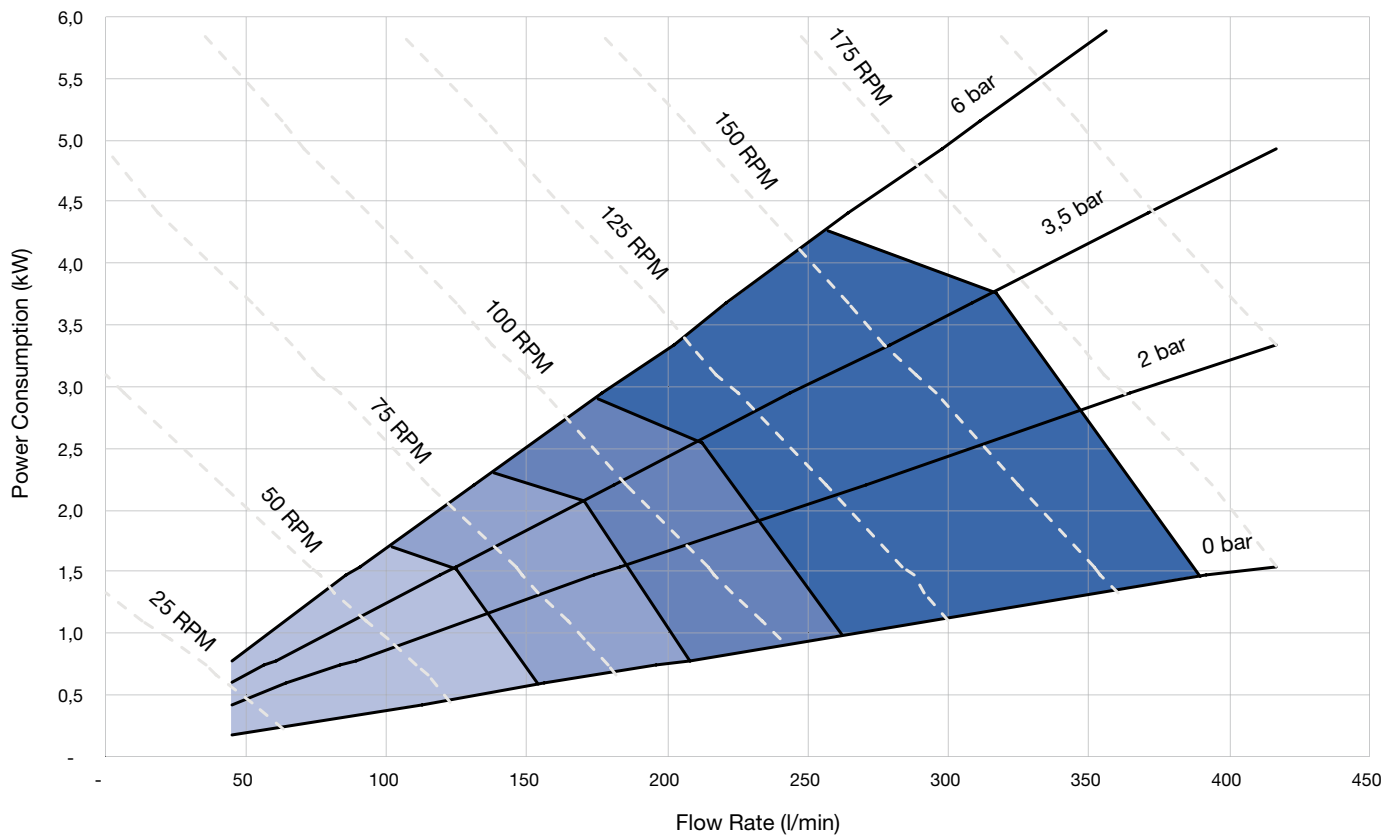

2.2 kW recommended
 3.0 kW recommended
 4.0 kW recommended
 5.5 kW recommended

080-VA-18_Datasheets_EODD50_EU



Find your local supplier at www.verderair.com

For construction, installation and floor mounting drawings please contact your local authorised Verderair® distributor.

VERDER
passion for pumps