

The Packo pumps of the MCP3 series are used in almost all industries such as vegetable industry, breweries, water treatment and textile industry as well as in e.g. biogas, biodiesel and bioethanol applications. These robust pumps have stainless steel 316L cast pump casings and closed or channel investment cast impellers, constructed in 316L or duplex materials. Thanks to its solid construction and electro polished design these pumps are the reliable component for your production process.



Application areas

They are often used as process pump for contaminated water as well as for CIP cleaning systems, filtration of wine, mash, beer, whey and blanching of vegetables. Typical liquids: mash, wort, process and contaminated water, biodiesel, bioethanol, alcohols, CIP, biogas, etc.

Your benefits

- High pump efficiency resulting in lower energy consumption
- Low NPSH values: less risk on cavitation
- Electropolished
- Easy construction and easy maintenance: Less downtime
- Standard components
- Easy to install
- 3 mechanical seal diameters for the entire range
- Robust construction

Technical specifications

Max. flow rate	1250 m ³ /h
Max. differential head	70 m
Max. liquid viscosity	500 cP
Max. temperature	140°C
Impeller type	Closed (with back vanes and balancing holes) and channel impellers
Max. free passage	27 mm for closed impellers & 41 mm for channel impellers
Max. motor power	132 kW
Max. speed	3000 / 3600 rpm
Available frequency	50 / 60 Hz
Connections	Industrial flanges acc. to EN 1092-1/01 and ANSI
Materials wetted parts	Stainless steel 316L or similar
Available materials o-ring	EPDM, FKM, FEP-FKM, FFKM, Silicone
Mechanical seal configuration	Single, quench, double
Surface finish	Industrial finish: welds are not hand polished. Final surface treatment: electropolished
Certificates & Legislation	1935/2004 EC, FDA, ATEX, EU N° 547/2012



Performance curves

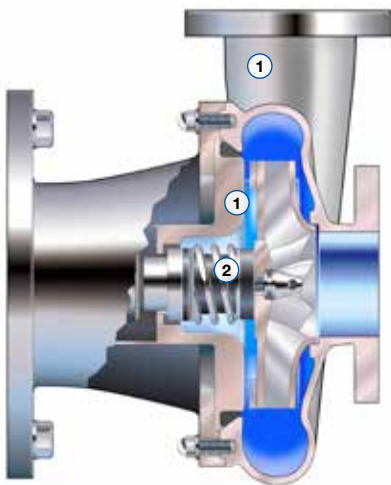
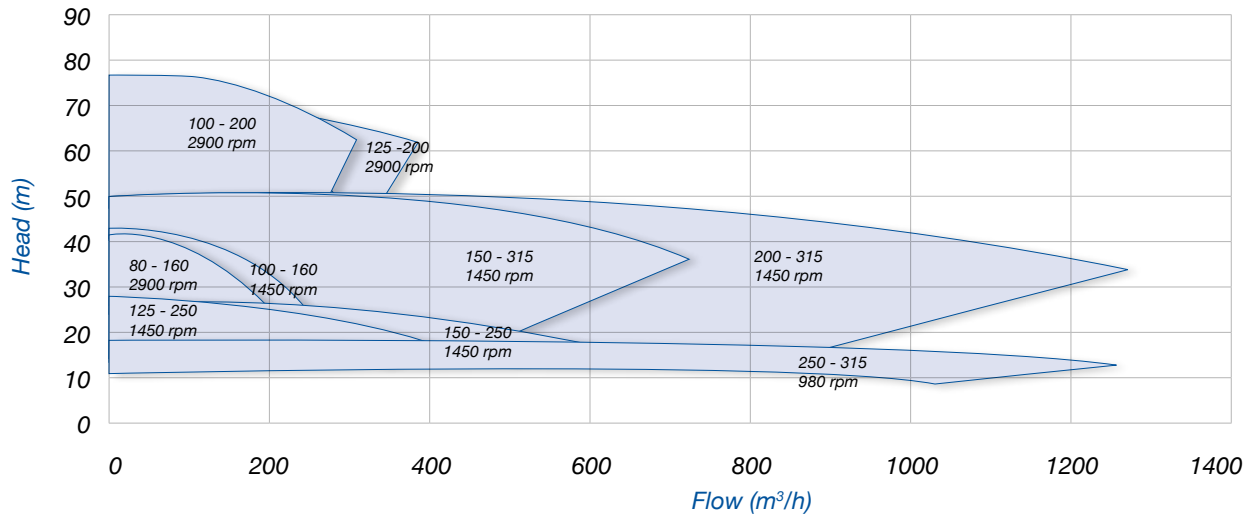

Specifications

- Solid design thanks to thick pressed casings and investment cast impellers (1)
- Standardized mechanical seals to EN 12756
- FDA approved bellows mechanical seals (2) or balanced O-ring seals
- Mechanical seal diameters (43 - 70 - 110 mm)
- Use of standardized components
- Electropolished design (for wetted & non-wetted parts); easy to clean and increased corrosion resistance



Electropolished

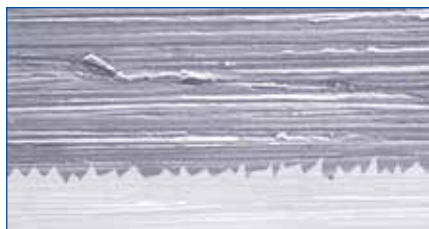

Mechanical polishing 240 grit

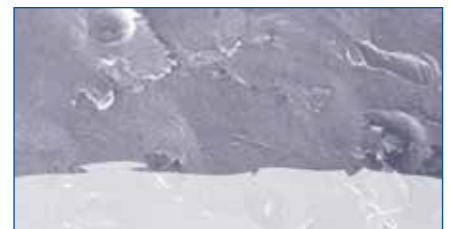

Glass bead blasted

MCP3_Industrial_pump_series_Technosheet_rev01_2016_(eu)



Find your local supplier at www.verder-liquids.com

For construction, installation and floor mounting drawings please contact your local authorised Verder® distributor.