

CHARACTERISTICS

	STANDARD	AVAILABLE OPTIONS
Technology	Eccentric Disc Mouvex®	
Maximum Flow rate at 1 cSt L/h (GPM)	18000 (79.25)	
Cubic capacity L (cu.in)	0,617 (37.71)	
Ports	DN 65 ISO PN16 flanges	ANSI150 flanges
Pump heating	None	Heating jacket
Dimensions mm (in.) (With ISO PN16 flanges)	A 788 (31.03)	
	B 253 (9.96)	
	C 458 (18.03)	
	D 340 (13.39)	
	E 343.5 (13.52)	
Weight kg (lbs)	122 (269)	

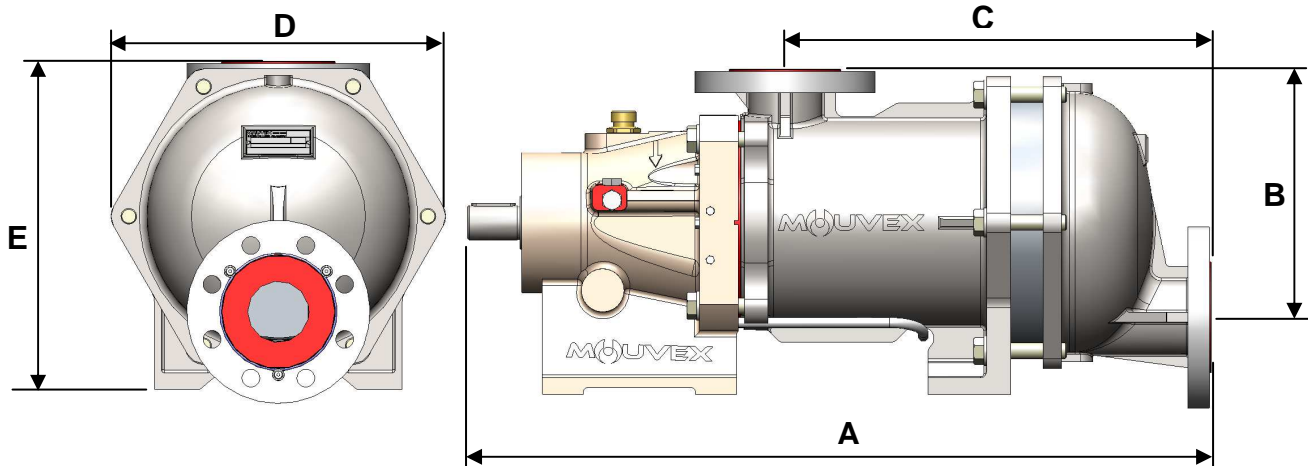

OPERATING LIMITS

	STANDARD MATERIALS
Minimum temperature °C (°F)	-15 (5)
Maximum temperature °C (°F)	Process: 100 (212)
Maximum viscosity cSt (SSU)	10000 (46350)
Maximum differential pressure bar (psi)	6 (87)
Maximum inlet pressure barg (psig)	1.5 (21.7)
Maximum speed rpm	530
Maximum solid particle size (mm/in)	2 (0.079)
Maximum soft particle size (mm/in)	10 (0.394)

MATERIALS OF CONSTRUCTION

Part No	PART NAME	STANDARD MATERIALS	AVAILABLE OPTIONS
101	Inlet Tube	316L Stainless Steel (low carbon)	
201	Cylinder	316L Stainless Steel (low carbon)	
301	Disc	CY5SnBiM (anti galling alloy)	
304	Disc Nut	316Ti Stainless Steel (Titanium Alloy)	
405A	Outlet Cover	316L Stainless Steel (low carbon)	
	Bolts	630 Stainless Steel	
596	Transmission Assembly		
	Bearings	Ball / Roller / Needle	
	Double Bellows Assembly	316Ti & 316 L Stainless Fabrication	
	Housing	Cast iron	
	Screws	Steel	
	Transmission Lubricant	Synthetic oil	
	Seal Rings	Fluorocarbon (FKM) O-Rings	L - FKM gaskets PTFE Encapsulated O-rings

