

PRIMEROYAL[®] N dosing pump

Hydraulically actuated diaphragm liquid end • Packed plunger liquid end

• Flow rate up to 9863 l/h • Pressure up to 500 bar



Main mechanical characteristics

- Reciprocating dosing pump with variable stroke length
- Stroke micrometric adjustment while running or stopped
- Fixed stroke version available
- Multiplexing capability up to 2x3 heads
- Maximum stroke length: 63 mm
- Stroke speeds at 50 Hz - 1000 rpm: 64 and 78 spm
- Stroke speeds at 50 Hz - 1500 rpm: 96, 117, 149 and 175 spm
- Design end load: 2000 daN

Main liquid end configurations

- Packed plunger liquid end ("UT"):
 - Liquid end body: 316L stainless steel
 - Plunger: 316L chromium oxide coated
 - Flushing ring
- Diaphragm liquid end ("M"):
 - Liquid end body: 316L stainless steel
 - Diaphragm: metallic, single or double
 - Hydraulically actuated diaphragm
- Diaphragm liquid end ("H") or ("P"):
 - Liquid end body: 316L stainless steel ("H") or plastic ("P")
 - Diaphragm: PTFE
 - Hydraulically actuated diaphragm
 - "HPD" patented design, life currently exceeding 20,000 hours



PRIMEROYAL[®] N dosing pump, Simplex version equipped with a diaphragm liquid end

Main electrical characteristics

- Motor power supply: 400 V - 50 Hz - 3 phase as standard. Other voltages/frequencies on request
- Electric equipment for non hazardous or hazardous area, large variety of protections and insulations
- Conforming to European standards, Nema motors available

Options

- Double or triple diaphragm
- Diaphragm failure detection
- Cooling/heating jacket
- Thermal barrier
- Special materials
- Food grade design
- Slurry configuration
- Special valves
- Automatic flow rate adjustment: electronic servomotor (waterproof or explosion-proof), pneumatic servomotor
- Remote head
- Stroke counter
- Low temperature
- Sand-proof
- Special designs available



PRIMEROYAL[®] N dosing pump - Triplex version with fixed stroke

Principle

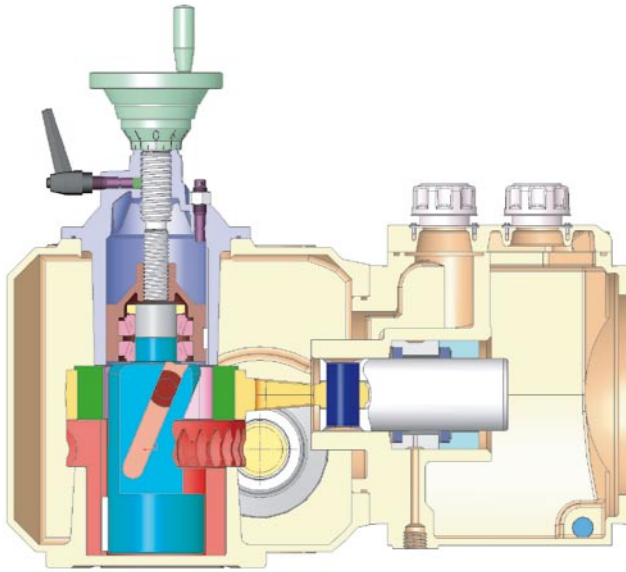

Stroke adjusted to 0%

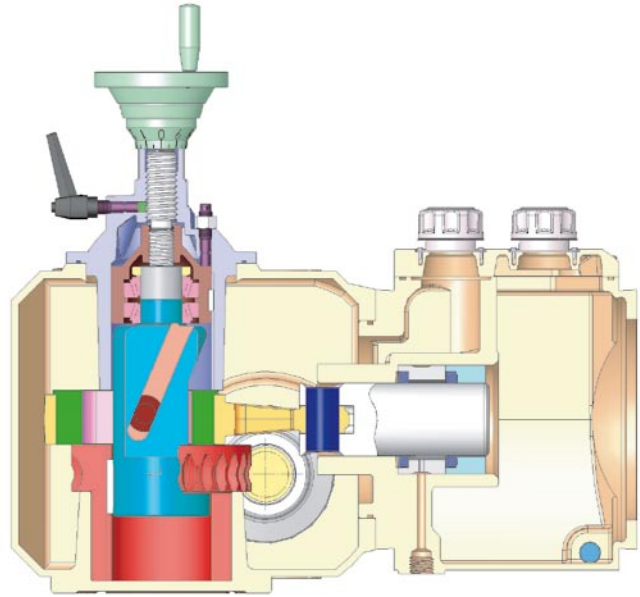

Stroke adjusted to 100%

Performance

- Conformity to API 675 for adjustable stroke version
- Conformity to API 674 for fixed stroke version
- In accordance with ATEX CE EX II 2G/D c T3 or T4 on request

316L chromium oxide coated plunger and 316L stainless steel liquid end ("UT")

Ø Plunger (mm)	Swept volume (cm ³)	Stroke speed max. (spm) Motor speed 1500 rpm	Flow rate max. (l/h)		Pressure max. (bar)	Connections
			10 bar	P. max.		
19.1	17.96	175	181	145	500	1/2" - VV1 m
25.4	31.92	175	321	272	389	1/2" - VV1 m
31.8	49.88	175	502	454	248	1" - VV1 m
38.1	71.83	175	724	677	172	1" - VV1 m
44.5	97.76	175	985	939	126	1" - VV1 m
50.8	127.69	175	1287	1242	96	1" - VV1 m
57.2	161.61	175	1629	1586	75	1" 1/2 - VV1 m
63.5	199.52	175	2011	1969	61	2" - VV1 m
69.9	241.41	175	2433	2394	50	2" - VV1 m
79.4	311.74	175	3142	3106	38	2" - VV1 m
88.9	391.05	175	3941	3909	30	2" - VV1 m
101.6	510.76	149	4383	4360	23	3" - VV3 m - 150 lbs
127	798.06	149	6849	6838	14	3" - VV3 m - 150 lbs
152.4	1149.21	149	9863	9863	10	3" - VV3 m - 150 lbs



Metallic diaphragm liquid end ("M")

	Ø Plunger (mm)	Swept volume (cm ³)	Ø Diaphragm (mm)	Stroke speed max. (spm) Motor speed 1500 rpm	Flow rate max. (l/h)		Pressure max. (bar)	Connections
					10 bar	P. max.		
Single diaphragm	16	12.66	162	175	122	86	500	1/2" - VV1 m
	18	16.03	182	175	154	108	500	1" - VV1 m
	20	19.79	212	175	191	134	500	1" - VV1 m
Double diaphragm	16	12.66	162	175	122	80	350	1/2" - VV1 m
	18	16.03	182	175	154	101	350	1" - VV1 m
	20	19.79	212	175	191	126	350	1" - VV1 m

HPD diaphragm and metallic liquid end ("H")

Ø Plunger (mm)	Swept volume (cm ³)	Ø Diaphragm (mm)	Stroke speed max. (spm) Motor speed 1500 rpm	Flow rate max. (l/h)		Pressure max. (bar)	Connections
				10 bar	P. max.		
25	30.92	106	149	262	155	300	1/2" - VV1 m
32	50.66	166	149	430	383	87	1" - VV1 m
32	50.66	168	175	505	378	248	1" - VV1 m
40	79.16	166	149	672	599	87	1" - VV1 m
40	79.16	168	175	789	694	159	1" - VV1 m
50	123.70	166	149	1050	936	87	1" - VV1 m
50	123.70	168	175	1233	1143	101	1 1/2" - VV1 m
55	149.67	166	149	1271	1137	84	1" - VV1 m
55	149.67	168	175	1493	1404	84	1 1/2" - VV1 m
63	196.38	266	175	1958	1889	35	1 1/2" - VV1 m
63	196.38	168	175	1958	1873	64	1 1/2" - VV1 m
80	316.67	266	175	3158	3029	39	1 1/2" - VV1 m
90	400.78	266	149	3403	3302	31	1 1/2" - VV1 m
100	494.80	266	149	4202	4113	25	1 1/2" - VV1 m
125	773.12	366	149	6427	6002	16	3" - VV3 - 150 lbs
145	1040.31	366	149	8649	8458	12	3" - VV3 - 150 lbs

HPD diaphragm and plastic liquid end ("P")

Ø Plunger (mm)	Swept volume (cm ³)	Ø Diaphragm (mm)	Stroke speed max. (spm) Motor speed 1500 rpm	Flow rate max. (l/h) P. max.	Pressure max. (bar)	Connections
100	494.80	266	117	3299	10	1 1/2" - VV1 f
125	773.12	366	117	5047	10	3" - VV3 - 150 lbs
145	1040.31	366	117	6791	10	3" - VV3 - 150 lbs

General dimensions (in mm)

The general dimensions are given as an indication only.
 The dimensions given correspond to the maximum dimensions (largest liquid end, most powerful motor).

Diaphragm liquid end simplex configuration

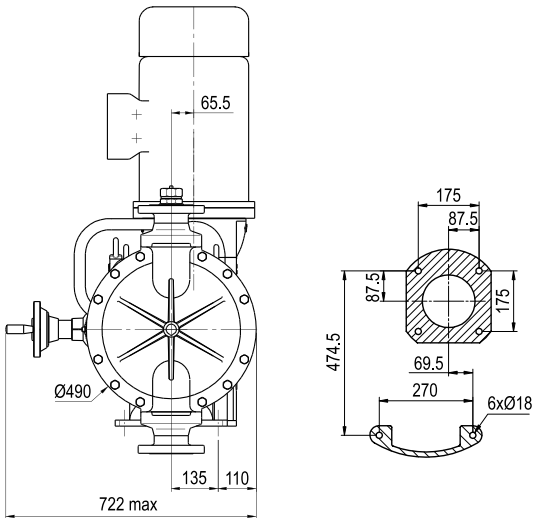
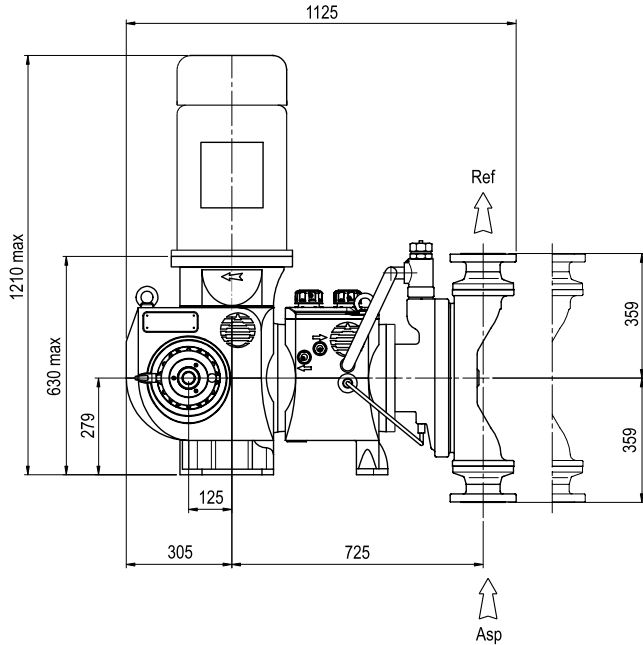

Diaphragm liquid end triplex configuration

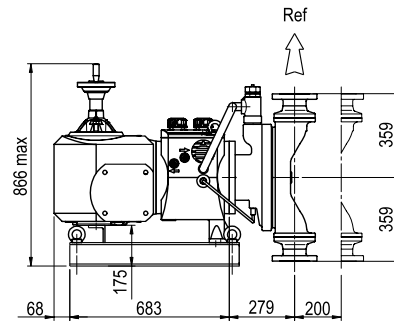
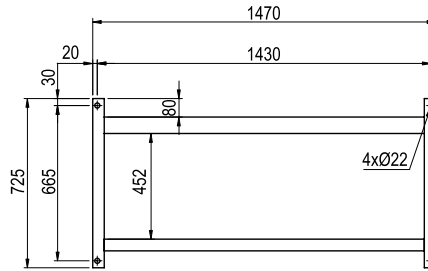
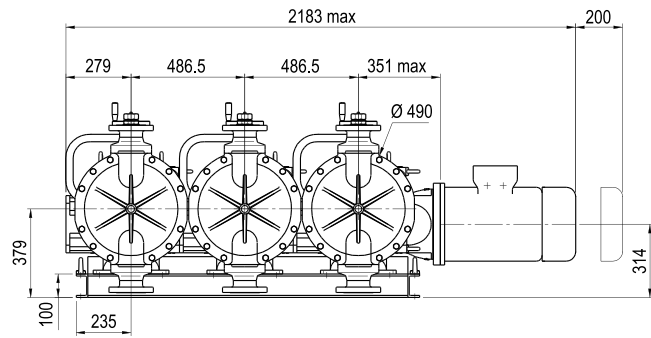

Caption: • Asp: suction
 • Ref: discharge
 ↑ Asp

Weight and packing

Version	Net Weight (*) kg	Gross Weight (*) kg	Packing (mm) (L x W x H)
PRIMEROYAL® N simplex	450	635	1380 x 880 x 1600

(*) Approximately



A network of over 100 distributors and sales and service offices.

To find your local representative, visit our website:

www.miltonroy-europe.com

PRIMEROYAL® N - Ref. 160 5604 201N - 06/07 - Rev. C

All rights reserved for modification without prior notice - SIREN 663 650 547 B - RC Evreux - Printed in France.



VERDER NV

Kontichsesteenweg 17

B-2630 Aartselaar

Belgium

TEL +32 3 877 11 12

FAX +32 3 877 05 75

MAIL info@verder.be

WEB www.verder.be