

PRIMEROYAL[®] K dosing pump

- Hydraulically actuated diaphragm liquid end • Packed plunger liquid end
- Flow rate up to 2062 l/h • Pressure up to 500 bar



Main mechanical characteristics

- Reciprocating dosing pump with variable stroke length
- Stroke micrometric adjustment while running or stopped
- Multiplexing capability up to 2x6 heads
- Maximum stroke length: 40 mm
- Stroke speeds at 50 Hz - 1000 rpm: 39 and 120 spm
- Stroke speeds at 50 Hz - 1500 rpm: 59, 100, 144 and 180 spm
- Design end load: 475 daN

Main liquid end configurations

- Packed plunger liquid end ("UT"):
 - Liquid end body: 316L stainless steel
 - Plunger: 316L chromium oxide coated
 - Flushing ring
- Diaphragm liquid end ("M"):
 - Liquid end body: 316L stainless steel
 - Diaphragm: metallic, single or double
 - Hydraulically actuated diaphragm
- Diaphragm liquid end ("H") or ("P"):
 - Liquid end body: 316L stainless steel ("H") or plastic ("P")
 - Diaphragm: PTFE
 - Hydraulically actuated diaphragm
 - "HPD" patented design, life currently exceeding 20,000 hours

Main electrical characteristics

- Motor power supply: 400 V - 50 Hz - 3 phase as standard. Other voltages/frequencies on request
- Electric equipment for non hazardous or hazardous area, large variety of protections and insulations
- Conforming to the European standards, Nema motors available

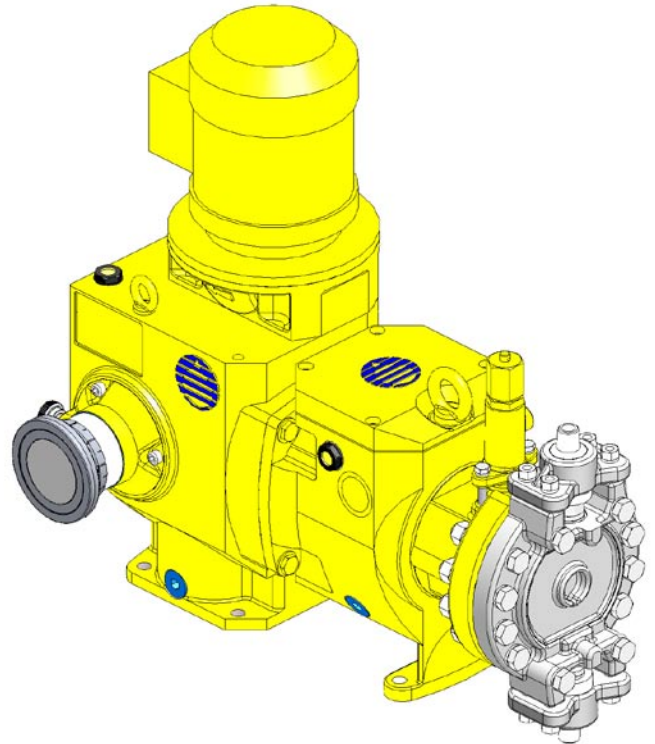

*PRIMEROYAL[®] K dosing pump, simplex version
equipped with a diaphragm liquid end*

Options

- Double or triple diaphragm
- Diaphragm failure detection
- Cooling/heating jacket
- Thermal barrier
- Special materials
- Food grade design
- Slurry configuration
- Special valves
- Automatic flow rate adjustment: electronic servomotor (waterproof or explosion-proof)
- Remote head
- Rev counter
- Low temperature
- Sand-proof
- Special designs available

Principle

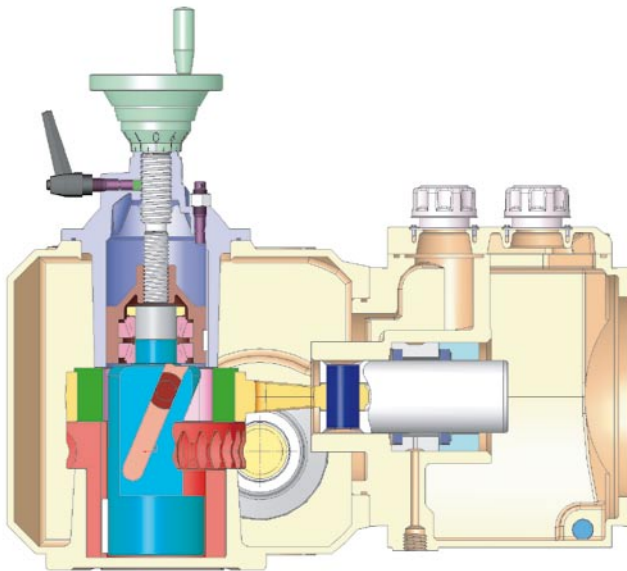

Stroke adjusted to 0%

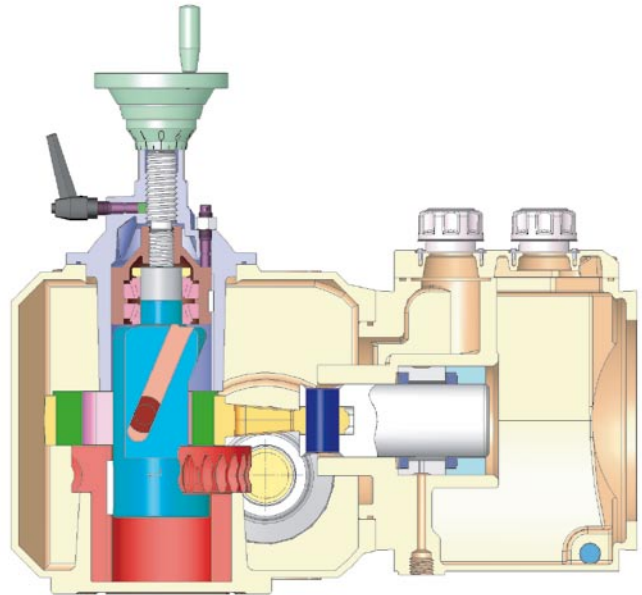

Stroke adjusted to 100%

Performance

- Conformity to API 675
- In accordance with ATEX CE EX II 2G/D c T3 or T4 on request

316L chromium oxide coated plunger and 316L stainless steel liquid end ("UT")

Ø Plunger (mm)	Swept volume (cm ³)	Stroke speed max. (spm) Motor speed 1500 rpm	Flow rate max. (l/h)		Pressure max. (bar)	Connections
			10 bar	P. max.		
9.5	2.85	180	29.5	23.7	500	1/2" - VV1 m
12.7	5.07	180	52	44	364	1/2" - VV1 m
15.9	7.92	180	82	74	231	1/2" - VV1 m
19.1	11.40	180	118	110	159	1/2" - VV1 m
25.4	20.27	180	210	203	88	1/2" - VV1 m
31.8	31.67	180	328	322	55	1/2" - VV1 m
38.1	45.60	180	472	466	38	1" - VV1 m
44.5	62.07	180	643	638	27	1" - VV1 m
50.8	81.07	180	840	836	20	1" - VV1 m
57.2	102.61	180	1063	1060	16	1" - VV1 m
63.5	126.68	180	1313	1311	12	1" - VV1 m
69.9	153.28	180	1589	1589	10	2" - VV1 m
79.4	197.93	144		1642	7	2" - VV1 m
88.9	248.29	144		2062	6	2" - VV1 m

HPD diaphragm and metallic liquid end ("H")

Ø Plunger (mm)	Swept volume (cm ³)	Ø Diaphragm (mm)	Stroke speed max. (spm) Motor speed 1500 rpm	Flow rate max. (l/h)		Pressure max. (bar)	Connections
				10 bar	P. max.		
20	12.57	106	180	128	102	151	1/2" - VV1 m
25	19.63	106	180	201	176	96	1/2" - VV1 m
32	32.17	106	180	330	307	59	1/2" - VV1 m



HPD diaphragm and plastic liquid end ("P")

Ø Plunger (mm)	Swept volume (cm ³)	Ø Diaphragm (mm)	Stroke speed max. (spm) Motor speed 1500 rpm	Flow rate max. (l/h)	Pressure max. (bar)	Connections
32	32.17	106	180	330	10	1/2" - VV1 f

Single or double metallic diaphragm liquid end ("M")

Ø Plunger (mm)	Swept volume (cm ³)	Ø Diaphragm (mm)	Stroke speed max. (spm) Motor speed 1500 rpm	Flow rate max. (l/h)			Pressure max. (bar)		Connections
				10 bar	P. max. single diaphragm	P. max. double diaphragm	single diaphragm	double diaphragm	
8	2.01	92	180	20	14.1	13.2	500	350	1/2" - VV1 m
10	3.14	112	180	31	21	20	500	350	1/2" - VV1 m
12	4.52	112	180	44	33	29	419	350	1/2" - VV1 m
14	6.16	132	180	61	50	42	308	308	1/2" - VV1 m
16	8.04	132	180	79	68	61	236	236	1/2" - VV1 m
18	10.18	162	180	101	90	83	186	186	1/2" - VV1 m
20	12.57	162	180	124	113	106	151	151	1/2" - VV1 m
22	15.21	182	180	151	140	133	124	124	1" - VV1 m
25	19.63	182	180	195	184	178	96	96	1" - VV1 m

General dimensions (in mm)

HPD diaphragm liquid end simplex configuration

The general dimensions are given as an indication only.

The dimensions given correspond to the maximum dimensions (largest liquid end, most powerful motor).

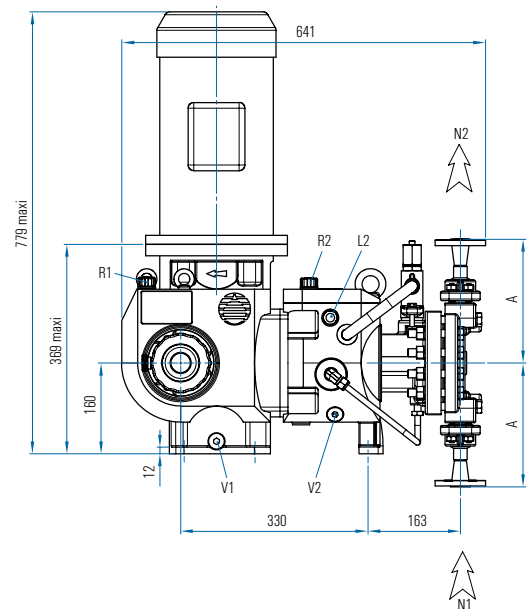
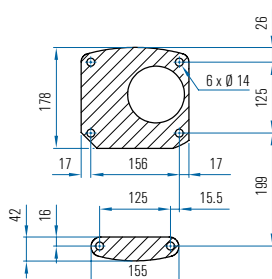
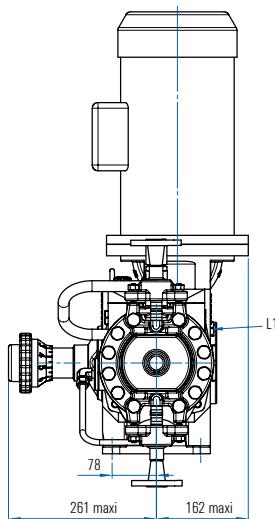

- N1: Suction
- N2: Discharge
- V2: Drain hydraulic oil
- L2: Hydraulic oil level
- R2: Hydraulic oil filling
- V1: Drain mechanic oil
- R1: Mechanic oil filling
- L1: Mechanic oil level

Model	Dimension (mm)	Connections
D20-25	A = 218	N1 = ANSI 1/2" 150 LBS RF / SF N2 = ANSI 1/2" 150 LBS RF / SF
D32	A = 239	N1 = ANSI 1/2" 150 LBS RF / SF N2 = ANSI 1/2" 150 LBS RF / SF

HPD diaphragm liquid end triplex configuration

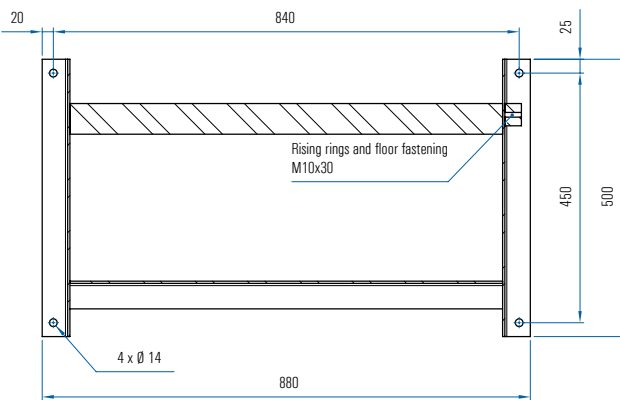
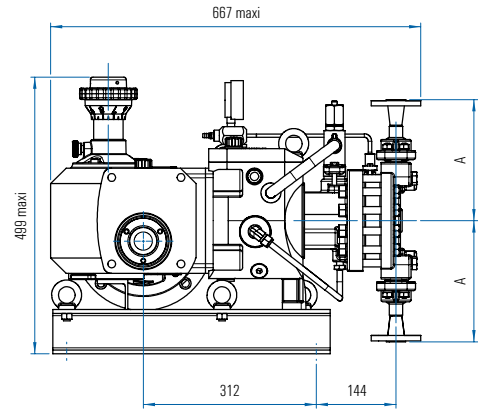
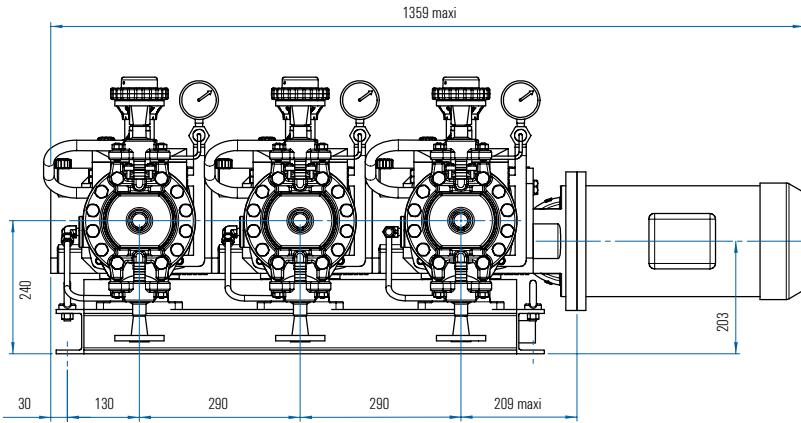

Model	Dimension (mm)	Connections
D20-25	A = 218	N1 = ANSI 1/2" 150 LBS RF / SF
D32	A = 239	N2 = ANSI 1/2" 150 LBS RF / SF

Weight and packing

Version	Net weight (*) kg	Gross weight (*) kg	Packing (mm) (L x W x H)
PRIMEROYAL® K simplex	150	200	900 x 600 x 1050

(*) Approximately



A network of over 100 distributors and sales and service offices.

To find your local representative, visit our website:

www.miltonroy-europe.com



VERDER NV
 Kontichsesteenweg 17
 B-2630 Aartselaar
 Belgium

TEL +32 3 877 11 12
FAX +32 3 877 05 75
MAIL info@verder.be
WEB www.verder.be