

Dosing pumps MAXROY® series A, B and D

Maximum flow rate: 1110 l/h • Maximum pressure: 28 bar • Hydraulically actuated diaphragm



Technical characteristics

- Flow rate up to:
 - 64 l/h for MAXROY® D105
 - 410 l/h for MAXROY® A105
 - 420 l/h for MAXROY® B105
 - 1100 l/h for MAXROY® B145
- Pressure up to:
 - 10 bar for MAXROY® A105 and B145
 - 28 bar for MAXROY® B105 and D105
- Maximum temperature of pumped liquid:
 - +90 °C for metallic liquid end
 - +50 °C for plastic liquid end
- Adjustment of flow rate while running or stopped: from 0 to 100%
- Accuracy: ± 1% of rated flow from 10% to 100% stroke
- Internal safety valve, normally set at the factory
 - Optional relief valve setting
- Suction lift: up to 2 m water save for "Viscous Liquids" version
- Maximum suction pressure condition: 2 bar
- Working life of the diaphragm can exceed 20,000 hours depending on the pumped fluid, working conditions and installation
- Single or double diaphragm
- Multiplexing available
- Can comply with API 675
- Explosion-proof version is in accordance with ATEX CE II 2 G/D c T4 (plastic liquid end, please consult us)



MAXROY® A dosing pump - Plastic liquid end

Options

- Flexible coupling (API 675)
- Double diaphragm with rupture detector
- Automatic flow rate adjustment: electronic servomotor, explosion-proof servomotor, pneumatic servomotor, frequency variation
- Flange connections
- Stroke counter

Liquid end construction

COMPONENTS	CONSTRUCTION	
	PVC ⁽¹⁾	316L ⁽²⁾
Liquid end body	PVC	316L
Check valve cartridge	PVC	316L
Seats	PE ⁽³⁾	316L
Balls	Glass ⁽³⁾	316L
Contour plate	PVC	316L
Diaphragm	PTFE	PTFE
Discharge ball spring	Hastelloy C	316L
Seals	Viton ⁽⁴⁾	PTFE

⁽¹⁾ Pressure is limited to 10 bar at 20 °C and pressure derated 1.1 bar / 5 °C.
Maximum operating temperature: 50 °C.

⁽²⁾ Milton Roy Europe keeps an interchangeability table for national and international standards (AFNOR, DIN, ASTM, BS, etc).

⁽³⁾ MAXROY® B145: PVC

⁽⁴⁾ Other material on request

OTHER LIQUID END MATERIAL

- "H₂SO₄ concentrated" version: 316L S.S. liquid end with seats in 904L and balls in Hastelloy C
- "Viscous liquids" version: 316L S.S. liquid end with balls in 316L S.S. and spring in Hastelloy C
- "Slurries" version: 316L S.S. liquid end with seats and balls in 440C
- "Polyelectrolytes" version: PVC liquid end with seats and balls in 316L and spring in Hastelloy C
- Other version on request: consult us

Electrical characteristics of motors

Standard motor data:

- Supply: 230/400 V, 3-phase, 50 Hz or 260/460 V, 3-phase, 60 Hz
- IM V1 mounting, FF130 flange, 14x30 mm shaft for MAXROY® A105, B145 and D105
- IM V1 mounting, FF165 flange, 19x40 mm or 24x50 mm shaft for MAXROY® B105
- Protection: IP 55, tropicalized (90%)
- Insulation: class F
- Ambient temperature: -16 °C to +40 °C
- Motor speed:
 - 1500 rpm for MAXROY® A105, B145 and D105
 - 1000 or 1500 rpm for MAXROY® B105
- Motors are in accordance with national and international standards
- Special or specific motors on request

Performances

Type	Plastic liquid end	Metallic liquid end		Stroke speed (spm) ⁽¹⁾	Gear	Plunger Ø (mm)	Diaphragm Ø (mm)	Swept volume (cm ³) ⁽³⁾
	Flow rate at 10 bar (l/h)	Flow rate at 10 bar (l/h)	Flow rate at 28 bar (l/h)					
MAXROY® D105	18		16	58	1/25	22	105	7.2
	32		28	96	1/15	22	105	7.2
	47		42	144	1/10	22	105	7.2
	58		52	180 ⁽²⁾	1/8	22	105	7.2
MAXROY® B105	84		84	36	1/25	41.1	105	38.8
	130		130	58	1/25	41.1	105	38.8
	209		209	96	1/15	41.1	105	38.8
	316		316	144	1/10	41.1	105	38.8
	391		391	180 ⁽²⁾	1/8	41.1	105	38.8
MAXROY® A105	127	127		58	1/25	50	105	38.8
	210	210		96	1/15	50	105	38.8
	322	322		144	1/10	50	105	38.8
	400	400		180 ⁽²⁾	1/8	50	105	38.8
MAXROY® B145	363	363		58	1/25	66.5	145	118.1
	621	621		96	1/15	66.5	145	118.1
	860	860		144	1/10	66.5	145	118.1
	1051	1051		180 ⁽²⁾	1/8	66.5	145	118.1

⁽¹⁾ Stroke rates are given for a motor speed of 1440 rpm.

Flow and stroke rates increase by 20% for a 60 Hz motor

⁽²⁾ Do not use with 60 Hz motor

⁽³⁾ Theoretical swept volume

MAXROY® D105

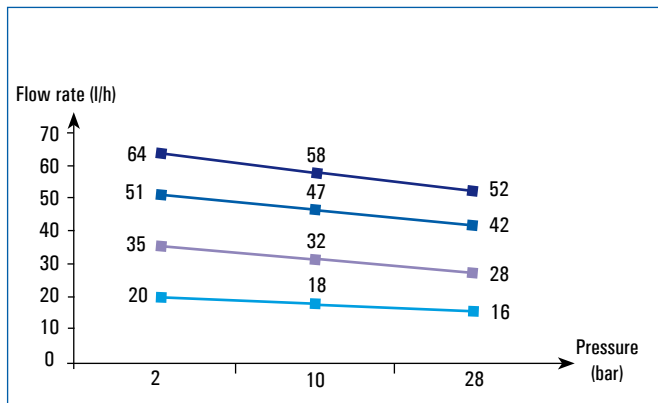

MAXROY® B105

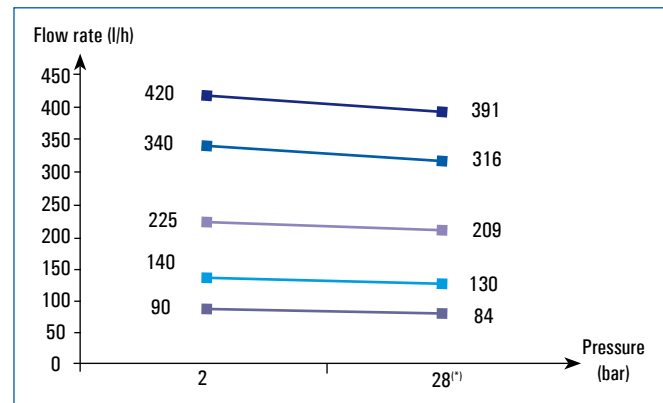

* Plastic liquid end: Pmax = 10 bar

MAXROY® A105

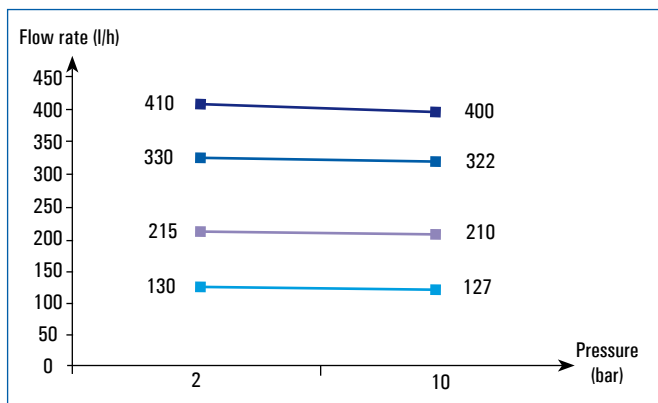

MAXROY® B145

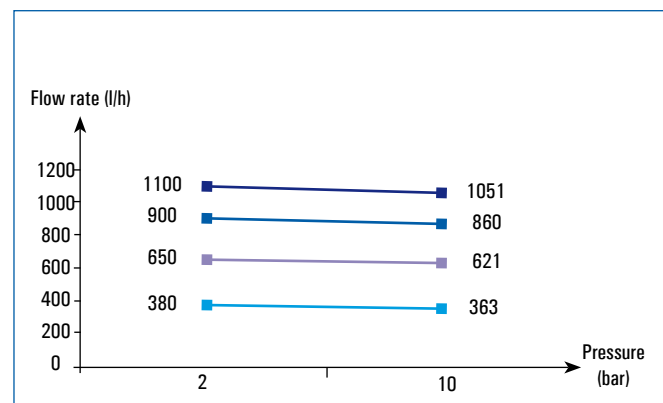

Dimensions (in mm)

MAXROY® A105 and D105 – Metallic liquid end Simplex version

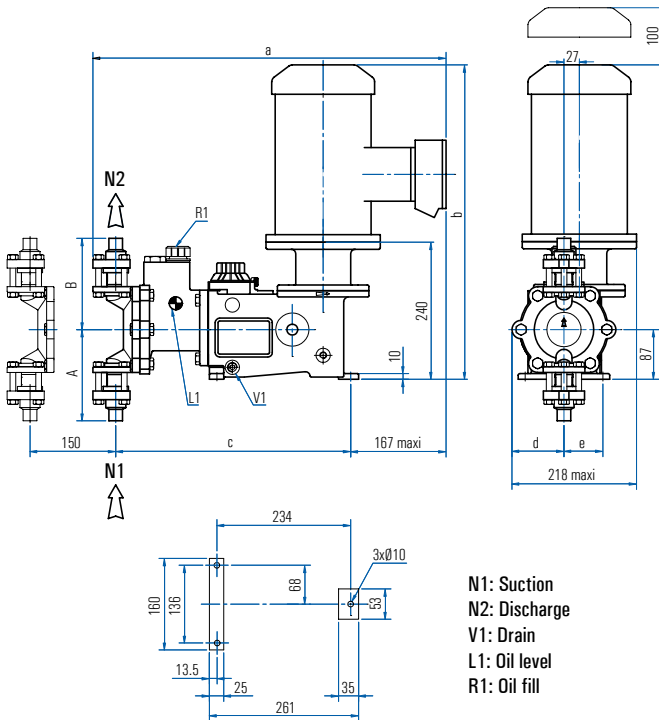

MAXROY® B105 – Plastic liquid end Simplex version

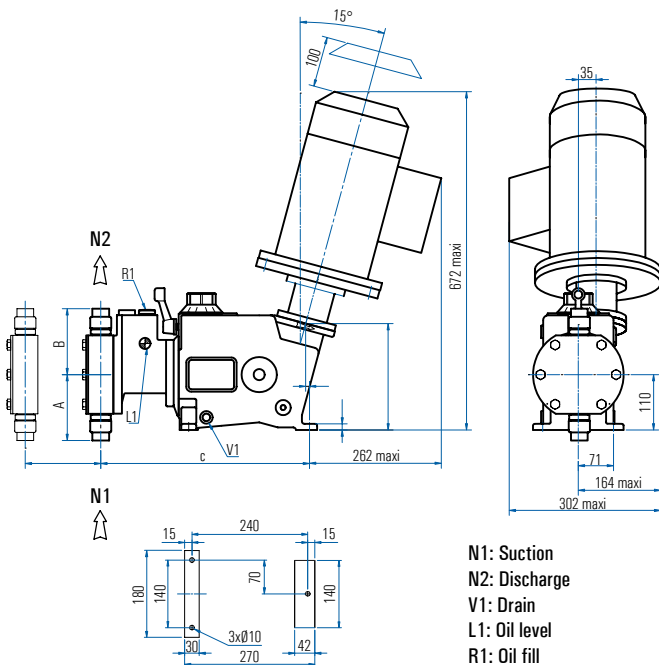

MAXROY® A105, D105 and B105

Models (spm)		Dimensions (mm)	Connections
Metallic liquid end			
All models (*)		a = 618 maxi b = 550 maxi c = 411 d = 91 e = 68	-
Screwed	58 - 96 - 144	A = 160 B = 160	N1 = R 1/2" G or 1/2" NPT N2 = R 1/2" G or 1/2" NPT
	180	A = 186 B = 160	N1 = R 3/4" G or 3/4" NPT N2 = R 1/2" G or 1/2" NPT
Welded	58 - 96 - 144	A = 160 B = 160	N1 = 1/2" N2 = 1/2"
	180	A = 186 B = 160	N1 = 3/4" N2 = 1/2"
Flanged	58 - 96 - 144	A = 208 B = 208 (**)	N1 = 1/2" ANSI 150 LBS N2 = 1/2" ANSI 150 LBS (**)
	180	A = 239 B = 208 (**)	N1 = 3/4" ANSI 150 LBS N2 = 1/2" ANSI 150 LBS (**)
Food grade	58 - 96 - 144	A = 160	DIN 11851 Ø 28 or SMS 1145 Ø 25
	180	B = 160	

Plastic liquid end

All models (*)		a = 597 maxi b = 539 maxi c = 394 d = 93 e = 66	-
Female plain socket	58 - 96 - 144	A = 131 B = 131	N1 = Ø 15x20 F N2 = Ø 15x20 F
	180	A = 160 B = 131	N1 = Ø 25x32 F N2 = Ø 15x20 F
Flanged	58 - 96 - 144	A = 195 B = 195	N1 = PN 10 DN 15 N2 = PN 10 DN 15
	180	A = 196 B = 195	N1 = PN 10 DN 25 N2 = PN 10 DN 15

(*) MAXROY® B105: c = 432 for metallic liquid end and 415 for plastic liquid end

(**) MAXROY® B105: B = 213 and N2 = 1/2" ANSI 300 LBS

**MAXROY® B145 – Plastic liquid end
 Simplex version**

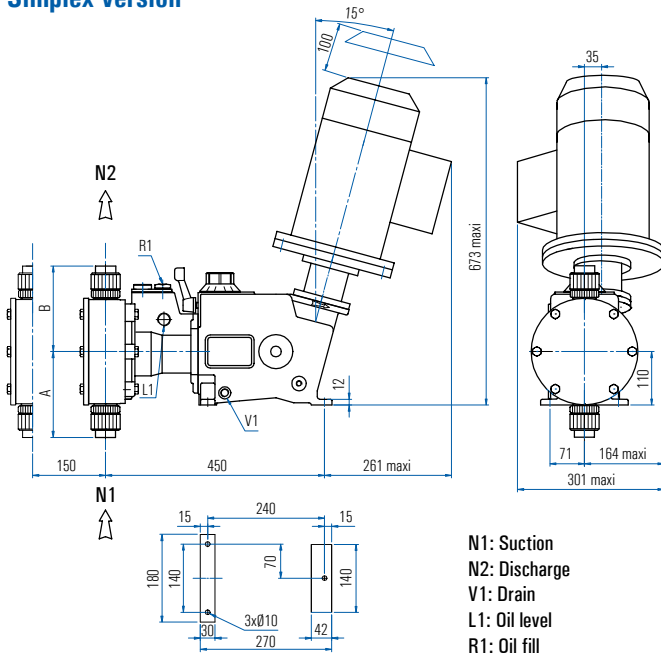

Models (spm)	Dimensions (mm)	Connections
Metallic liquid end		
Screwed	58 - 96 - 144	A = 191 B = 191 N1 = R 1" or 1"NPT N2 = R 1" or 1"NPT
	180	A = 231 B = 191 N1 = R 1 1/2" or 1 1/2"NPT N2 = R 1" or 1"NPT
Welded	58 - 96 - 144	A = 191 B = 191 N1 = 1" N2 = 1"
	180	A = 231 B = 191 N1 = 1 1/2" N2 = 1"
Flanged	58 - 96 - 144	A = 246 B = 246 N1 = 1" ANSI 150 LBS N2 = 1" ANSI 150 LBS
	180	A = 316 B = 246 N1 = 1 1/2" ANSI 150 LBS N2 = 1" ANSI 150 LBS
Food grade	58 - 96 - 144	A = 208 B = 208 DIN 11851 Ø 40 or SMS 1145 Ø 38
	180	A = 208 B = 208
Plastic liquid end		
Female plain socket	58 - 96 - 144	A = 176 B = 176 N1 = Ø 25x32 F N2 = Ø 25x32 F
	180	A = 219 B = 176 N1 = Ø 32x40 F N2 = Ø 25x32 F
Flanged	58 - 96 - 144	A = 217 B = 217 N1 = PN 10 DN 25 N2 = PN 10 DN 25
	180	A = 276 B = 217 N1 = PN 10 DN 25 N2 = PN 10 DN 25

**MAXROY® B105 - Metallic liquid end
 Duplex and Triplex versions**

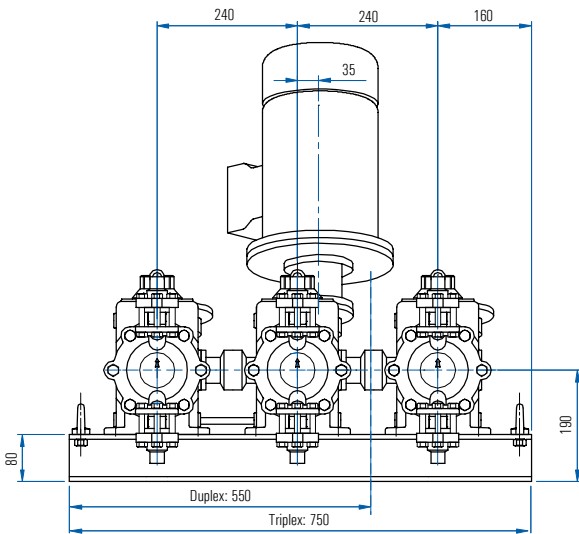

Protection

- As a standard pumps are protected with one coat of AMERON polyurethane paint of 100 microns, yellow RAL 1018
- Other treatment: consult us

Lubrication

- Ambient temperature from -5 °C to +50 °C: Oil ISO - VG150 equivalent
- Quantity:
 - 2.5 litres for MAXROY® A105 and D105
 - 4 litres for MAXROY® B105 and B145

Weight and Packing

Simplex version	Net weight (kg) (with oil) ⁽¹⁾	Gross weight (kg) (with packing) ⁽¹⁾	Packing ⁽²⁾ (L x W x H - mm)
MAXROY® A105 and D105	33	40	515 x 465 x 720
MAXROY® B105	57	67	800 x 400 x 900
MAXROY® B145	63	70	790 x 390 x 740

⁽¹⁾ Approximately - ⁽²⁾ Standard cardboard packing



A network of over 100 distributors and sales and service offices.

To find your local representative, visit our website:

www.miltonroy-europe.com

MAXROY® Series - Ref. 160 5502 201N - 07/08 - Rev. B

All rights reserved for modification without prior notice - SIREN 663 650 547 B - RC Evreux - Printed in France.



VERDER NV
 Kontichsesteenweg 17
 B-2630 Aartselaar
 Belgium

TEL +32 3 877 11 12
 FAX +32 3 877 05 75
 MAIL info@verder.be
 WEB www.verder.be