



SGL Series

Ductile Iron Pumps for Refrigerants and Other Liquefied Gas Service

SGL pumps are designed for the liquid transfer or recirculation of refrigerants and other liquefied gasses. Available in five sizes with capacities of 4 to 300 gpm (15 - 1,135 L/min), constructed of shock-resistant ductile iron and available with a wide variety of seal materials, an SGL pump is the pump to use for almost any liquefied gas application.

The sliding vane, positive displacement design provides excellent priming capability and high performance over a wide range of temperatures and differential pressures. The vanes self-adjust as they wear, maintaining the efficiency of a new pump. The vanes, liner and end discs are all easily replaced, bringing the pump back to like-new specifications.

Replaceable casing liner and end discs

Blackmer SGL models can be economically rebuilt for like-new performance with replaceable end discs and liners, specially designed to suppress cavitation and reduce wear.

Two-piece threaded lock collars

Precisely position the rotor and shaft, allowing the pump to operate under high inlet pressures. In addition, this positive lock thrust control helps prevent premature wear to internal components.

External ball bearings

Low friction grease-lubricated ball bearings are completely isolated from the pumpage by mechanical seals for trouble-free service and long life.

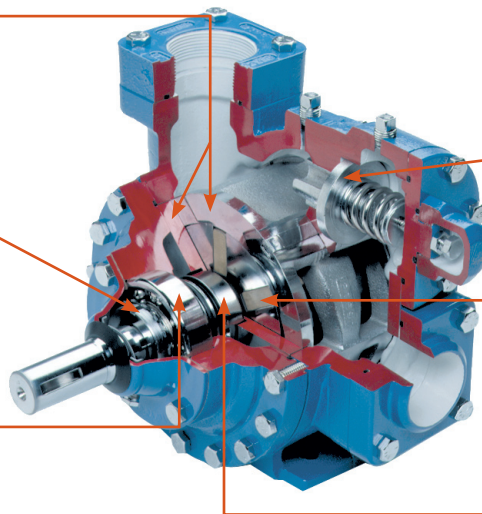

Ductile iron construction

All pressure parts are of ductile iron for greater resistance to both thermal and mechanical shock.

Internal relief valve

Protects the pump from excessive pressure buildup in the event of an obstructed or closed return line.

Nonmetallic Duravanes

Designed to resist wear under non-lubricating conditions. These chemically inert vanes are formulated of a tough resin material for long life and quiet operation.

Blackmer mechanical seals

Specially developed for non-lubricating liquids, Blackmer's exclusive component type design is field proven to provide long life and reliable service on a wide range of liquefied gas applications.

How sliding vane maintains efficiency

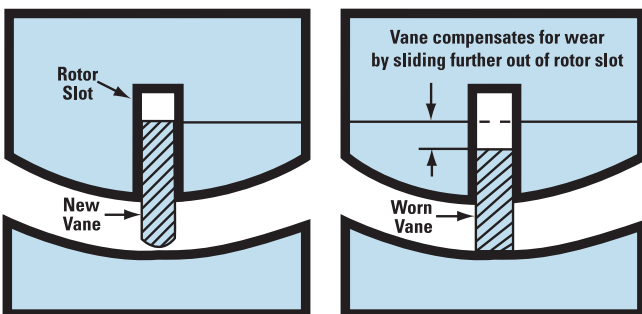

How Blackmer's sliding vane action works

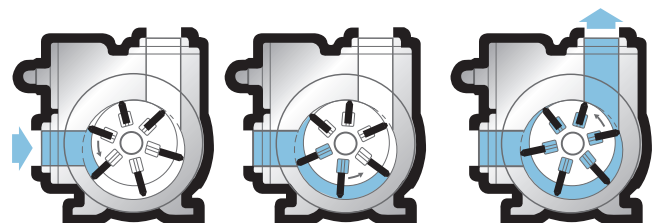



SGL Series Ductile Iron Pumps for Refrigerants and Other Liquefied Gas Service

Pump Performance Data

	Pump Model																				
	SGRL1.25				SGL1.25				SGL1.5				SGLD2			SGLD3			SGLD4		
Speed (rpm)	1,750	1,450	1,150	850	1,750	1,450	1,150	850	1,750	1,450	1,150	850	640	520	420	640	520	420	640	520	420
U.S. gpm	16	13	10	6	21	17	13	8	32	26	21	14	67	50	40	133	108	80	108	220	170
L/min	61	49	38	23	79	64	49	30	121	98	79	53	254	189	151	503	409	303	1,022	833	643
hp	1.3	1.1	0.9	0.7	1.7	1.4	1.2	0.9	2.2	1.8	1.4	1.2	3.9	3.1	2.5	8.0	6.7	5.2	15.5	12.2	10.0

* Approximate data based on handling various liquefied gasses as 50 psi (3.45 bar) differential pressure. Refer to characteristic curves for capacities and horsepower at other pressures.

Maximum Operating Limits

Pump Model	Nominal Flowrate		Pump Speed	Differential Pressure		Working Pressure		Minimum Temperature	
	gpm	L/min	rpm	psi	bar	psi	bar	°F	°C
SGRL1.25	16	61	1,750	150	10.3	525	36.2	-30	-34
SGL1.25	21	79	1,750	150	10.3	525	36.2	-30	-34
SGL1.5	32	121	1,750	150	10.3	525	36.2	-30	-34
SGLD2	67	254	640	150	10.3	525	36.2	-30	-34
SGLD3	133	503	640	150	10.3	525	36.2	-30	-34
SGLD4	270	1,022	640	125	8.6	525	36.2	-30	-34

Note: Optional materials of construction may be required to meet specific application requirements – refer to Blackmer Material Specification Sheets.

Companion Flanges

Pump Model	Standard	Optional
SGRL1.25 SGL1.25	1-1/4" NPT Tapped Ports	—
SGL1.5	1-1/2" NPT Tapped Ports	—
SGLD2	2" NPT	2" Weld
SGLD3	3" NPT	3" Weld
SGLD4	4"x 3" Weld	—

SGL Applications – Typical Products

- Butadiene
 - Butene
 - Dimethyl Ether
 - Ethyl Chloride
 - HCFC - 22
 - HFC - 23
 - HCF - 125
 - HCFC - 134a
 - HCFC - 142b
 - HFC - 143
 - HFC - 152a
 - MAPP Gas
 - Methyl Chloride
 - n-Pentane
 - R11
 - R12
 - R13
 - R22
 - R112
 - R113
 - R114
 - R115
 - R502
 - Refrigerants – MF/TA/TMS/TF
 - Most 400 & 500 Series Blends
 - Sulfur Dioxide
- ...and others

For Other Applications...

For propane/butane or anhydrous ammonia applications, consider Blackmer's LGL pumps or LB compressors. For CO₂ applications, consider Blackmer's CRL pumps or HD compressors. For railcar transfer, or where vapor recovery is desired, consider Blackmer's HD compressors.

Visit Blackmer's web site www.blackmer.com for more detailed information on the SGL pumps and other Blackmer products.



Distributed by:



World Headquarters
1809 Century Avenue SW
Grand Rapids, MI 49503-1530 USA
T 616.241.1611 F 616.241.3752

