

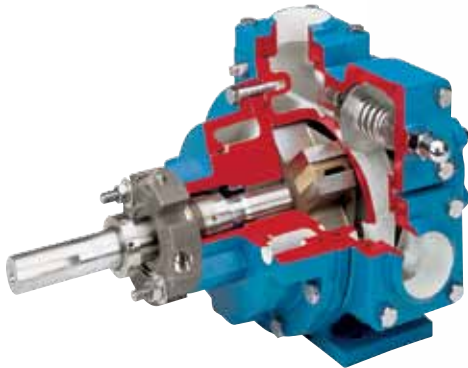

NP Series Fluid Processing and Transfer Sliding Vane Pumps

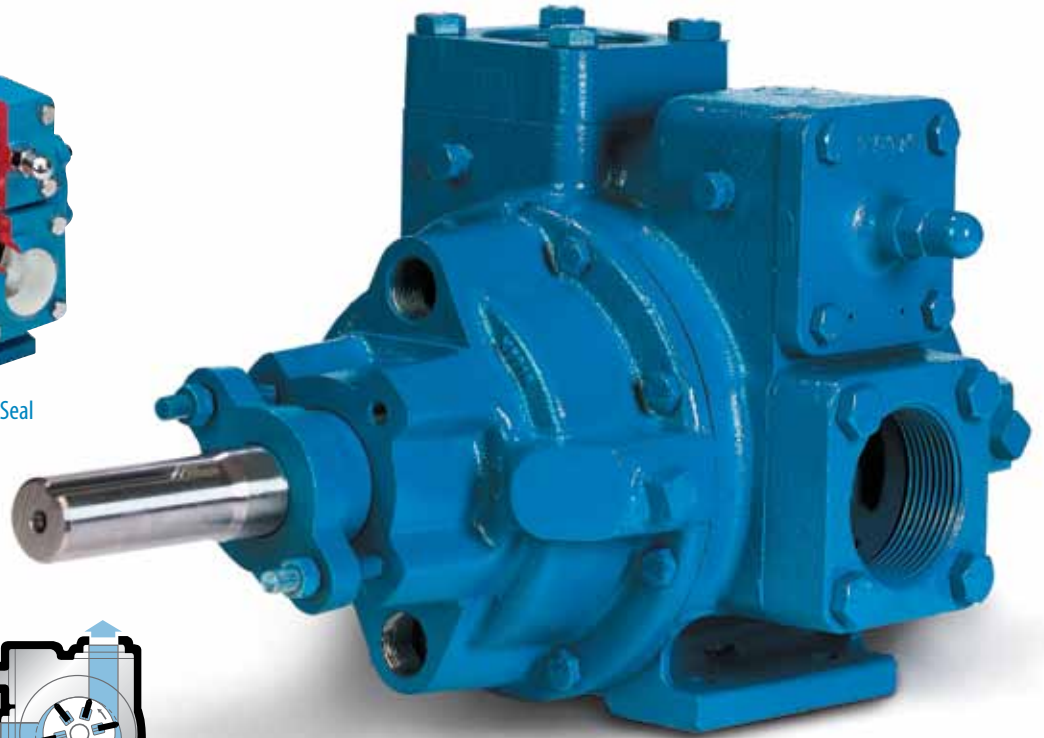

NP2 with Cartridge Mechanical Seal



NP2 with Steam Jackets

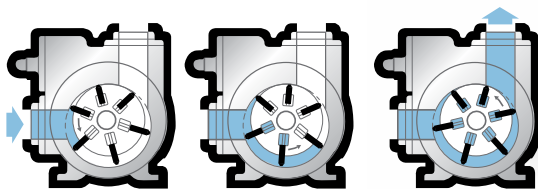

How Blackmer's sliding vane action works

Application Versatility

The NP type positive displacement sliding vane pumps are specially designed to offer maximum versatility for handling a wide range of clean, non-corrosive fluids.

Efficiency Means Energy Savings

The high volumetric efficiency and symmetrical bearing support of the NP pumps means they require less horsepower

than other PD pumps and up to 50% less power when handling viscous fluids. This means cost savings on both motors and electricity to operate the pumps.

Self-Priming and Dry Run Capability

The NP pumps are self-priming, and the self-adjusting vanes help maintain this capability. NP pumps can run dry for short periods of time for priming and line stripping.

High Viscosity

The NP pumps are ideal for handling viscous or shear sensitive fluids. The key to the NP series' versatility is Blackmer's unique sliding vane rotor design that provides sustained, high level performance over a wide viscosity range. Slow operating speeds and non-pulsating flow minimizes shear and agitation of the fluid. Optional Heating Jackets are available if required.



NP Series

Multipurpose Sliding Vane Pumps for a wide range of fluids and viscosities

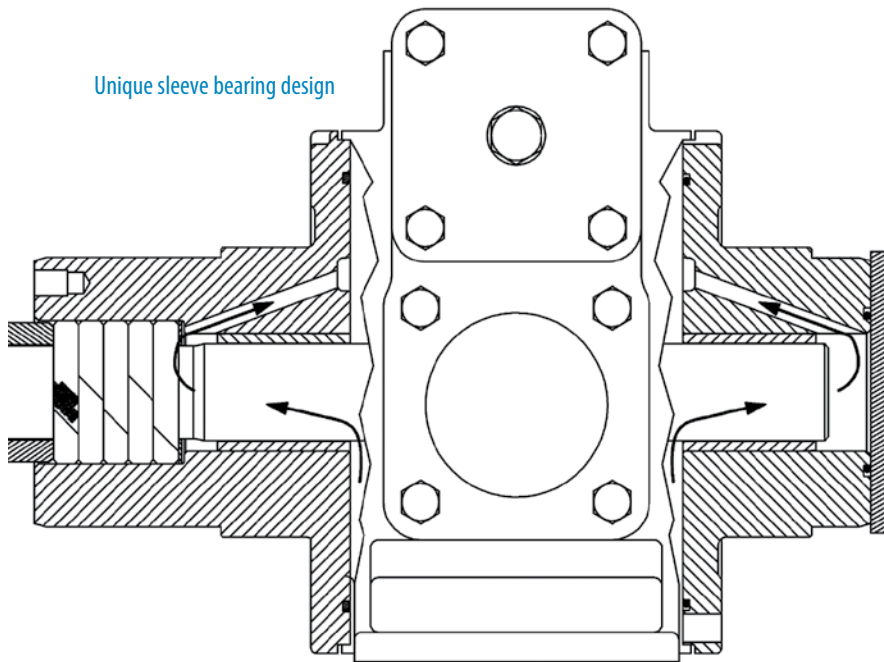

Long Bearing Life

The unique head and bearing design allows a small quantity of fluid to flow from the discharge side of the pump to the bearings. The pumpage is then drawn to the suction side of the pump through passages in the heads. The small, continuous flow of fluid over the bearing surfaces provides a hydrodynamic film, which minimizes temperature rise for longer bearing life.



Applications

- Refined Fuels
- Wax
- Greases
- Glues
- Solvents (VOC's)
- Adhesives
- Chocolate
- Creosote
- Syrup
- Asphalt
- Molasses
- Aqueous Film Forming Foam (AFFF)
- Edible Oils
- Black Liquor
- Sodium Silicate
- Tallow



Options and Specifications

Casing:

Cast iron construction

Drain Plugs:

Allow for easy draining, standard on ductile iron casing, optional on cast iron casing

Rotor & Shaft:

Ductile iron rotor with hardened steel shaft

Jacket Options:

Pumps available with optional Electric Heater ports or heating jackets for use with steam or hot oil. Both options heat the pump for highly viscous fluids and controlling bearing temperature. Electric heater ports are ready to accept standard heating elements. Steam and hot oil jackets use standard NPT connections.

Relief Valve:

Integral cast iron valve with steel spring (optional corrosion resistant relief valve with stainless steel spring)

Flanges: NP1.5" model:

NPT tapped casing ports

NP2, 2.5, 3 & 4" models:

NPT tapped companion flanges standard—optional weld neck, ANSI 150 lb. available

Elastomer:

FKM is standard. PTFE is optional.

Seals:

PTFE impregnated shaft packing is standard

Carbon filled PTFE lip seals, Blackmer triple lip seals, single or multiple cartridge mechanical seal options available.

Design Parameters

Flow Rates:

5 to 500 U.S. gpm
(19 to 1,893 L/min)

Operating Temperatures:

to 500°F (260°C)

Viscosity Range:

30-100,000 ssu
(1.0-22,000 cP)

Maximum Differential Pressure:

200 psi (13.8 bar)

300 psi (20.7 bar) hydrostatic pressure

Basic Design And Construction

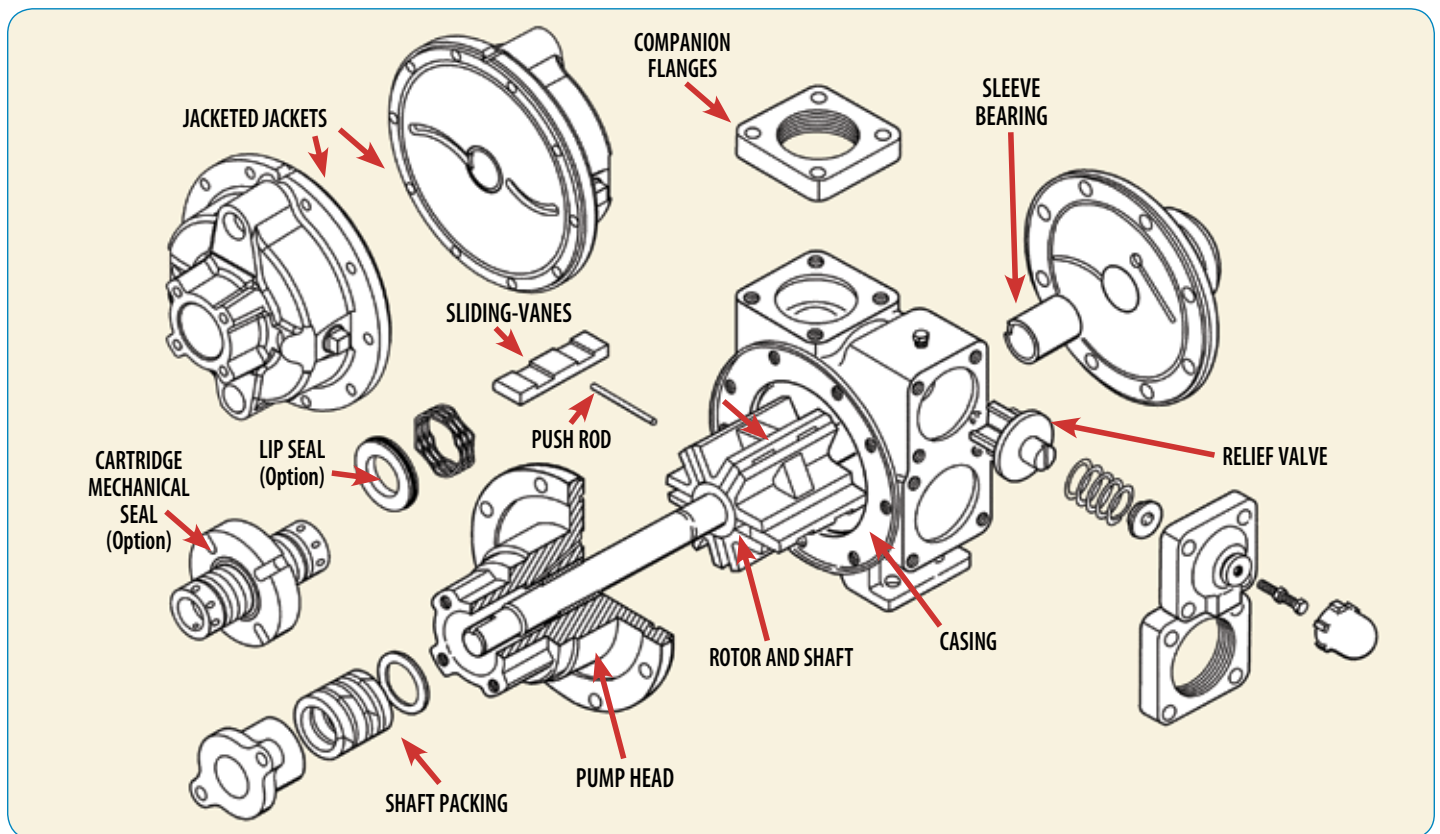



NP Series Fluid Processing and Transfer Pumps

Pump Performance Data*

Pump Model	NP1.5				NP2				NP2.5			
ssu	31	1,000	20,000	50,000	31	1,000	20,000	50,000	31	1,000	20,000	50,000
cP	1	210	4,200	11,000	1	210	4,200	11,000	1	210	4,200	11,000
gpm	38	45	24	10	60	70	38	16	110	122	64	28
L/min	144	170	91	38	227	265	144	61	416	462	242	106
Max rpm	640	640	350	155	640	640	350	155	640	640	350	155
bhp	1.7	2.2	2.2	0.9	2.8	2.8	2.6	1.2	4.7	5.1	4.3	2.1
kW	1.3	1.6	1.6	0.7	2.1	2.1	1.9	0.9	3.5	3.8	3.2	1.6

Pump Model	NP3				NP4			
ssu	31	1,000	20,000	50,000	31	1,000	20,000	50,000
cP	1	210	4,200	11,000	1	210	4,200	11,000
gpm	252	268	135	61	512	525	355	155
L/min	954	1,014	511	231	1,938	1,987	1,344	587
Max rpm	640	640	350	155	640	640	350	155
bhp	11.5	12.1	8.8	3.8	20	27	22	9
kW	8.6	9	6.6	2.8	14.9	20.1	16.4	6.7

* Approximate capacities and horsepower (bhp) are for the conditions specified at 50 psi (3.45 bar) differential pressure. Refer to Blackmer Characteristic Curves for capacities and horsepower at other operating conditions.

Maximum Operating Limits

Pump Model	Nominal Flowrate		Pump Speed rpm	Viscosity		Differential Pressure		Hydrostatic Pressure		Temperature	
	gpm	L/min		ssu	cP	psi	bar	psi	bar	°F	°C
NP1.5	47	178	640	100,000	22,000	200	13.79	300	20.68	500	260
NP2	77	291	640	100,000	22,000	200	13.79	300	20.68	500	260
NP2.5	136	515	640	100,000	22,000	200	13.79	300	20.68	500	260
NP3	276	1,045	640	100,000	22,000	200	13.79	300	20.68	500	260
NP4	525	1,985	500	100,000	22,000	200	13.79	300	20.68	500	260

Note: Optional materials of construction may be required to meet specific application requirements – refer to Blackmer Material of Construction Sheets. For operating limits that exceed those listed – consult factory.

Pump Dimensions

Pump Model	A	B	D	E	G	K	N	Q	S	T	V	Approx. Wt. with Std. Flanges	
NP1.5	in.	1	1/4	3 3/4	3 3/4	3 1/8	6 1/2	4	8 1/2	7	3 9/16	2 1/4	47 lbs.
	mm	—	—	95	95	79	165	102	216	178	90	57	21 kg
NP2	in.	1	1/4	11 1/4	4 7/8	3 1/2	6 1/2	3 1/2	8 3/4	5 7/8	3 7/8	1 1/2	65 lbs.
	mm	—	—	286	124	89	165	89	221	149	98	38	30 kg
NP2.5	in.	1 1/4	1/4	13	5 7/8	4 7/8	7	3 3/4	9 10/16	6 13/16	3 7/8	1 3/4	92 lbs.
	mm	—	—	330	149	124	178	95	244	173	98	44	42 kg
NP3	in.	1 1/4	1/4	13	5 7/8	4 3/8	7 1/4	4 10/16	12 1/4	8 9/16	4 7/8	2 1/2	134 lbs.
	mm	—	—	330	149	111	184	117	311	217	124	64	61 kg
NP4	in.	2	1/2	18	8 1/8	7	9 1/2	5	15 1/2	10 9/16	6 3/8	2 1/2	314 lbs.
	mm	—	—	457	206	178	241	127	394	268	162	64	142 kg

Note: Please refer to Blackmer catalog Dimension Sheets for optional jacketed head dimensions and NPT, weld neck, ANSI or DIN compatible companion flange dimensions.

Dimensions

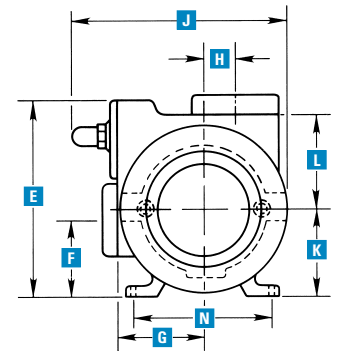
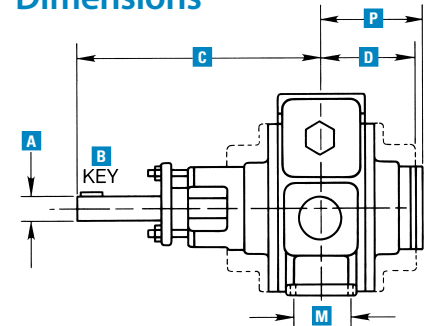

VERDER NV
Kontichsesteenweg 17
B-2630 Aartselaar
Belgium

TEL +32 3 877 11 12
FAX +32 3 877 05 75
EMAIL info@verder.be
WEB www.verder.be

AT Wien **BE** Aartselaar **BG** Sofia **CH** Basel **CN** Shanghai **CZ** Praha
DE Haan **DK** Rødovre **FR** Eragny s/Oise **GB** Castleford **HU** Budapest
IN Pune **NL** Groningen/Vleuten **PL** Katowice **RO** Bucuresti/Sibiu
SK Bratislava **TH** Bangkok **US** Macon (GA) **ZA** Northriding