

VERDERHUS



Stainless Steel Screw Channel Pump

Original Operating Manual

HSB

Version 1.0v-12/2018

Print-No. 01

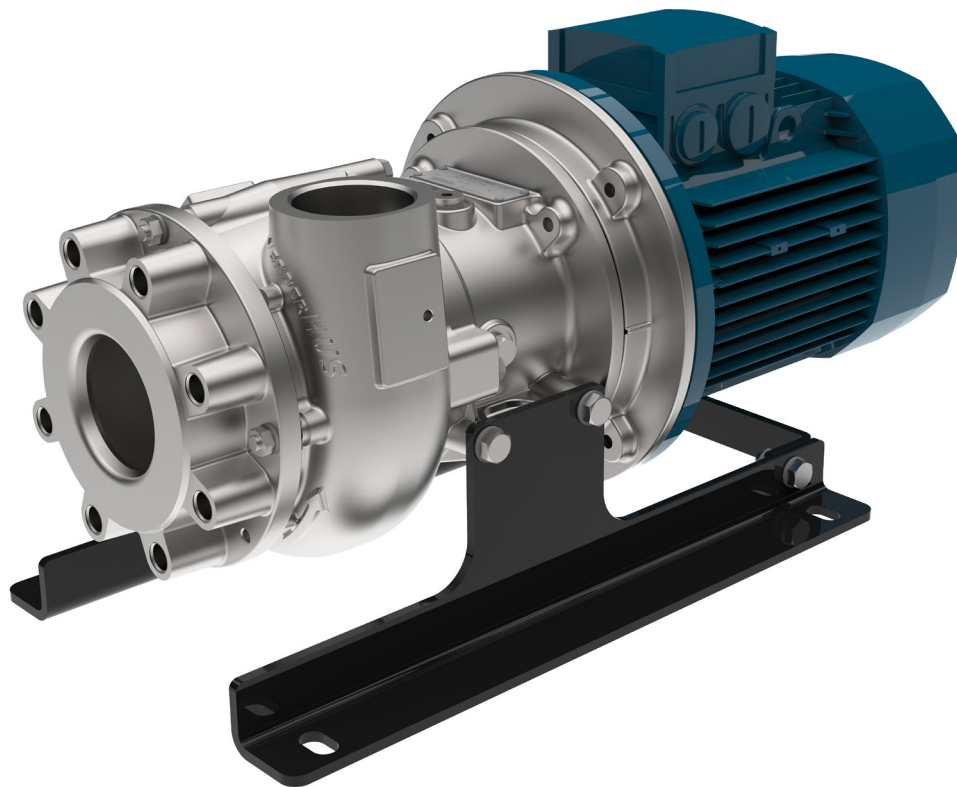

VERDER
passion for pumps



Version 1.0v -12/2018
Print-N o. 01

Series HSB SS 50 - 80



The information in this document is essential for the safe operation of Verderhus®. This document must be read and understood thoroughly prior to installation of pump, electrical connection and commissioning.

Table of Contents

1. About this Document

- 1.1 Target Groups
- 1.2 Warnings and Symbols Used in the Manual

2. Safety

- 2.1 Intended Use
- 2.2 General Safety Instructions
 - 2.2.1 Product Safety
 - 2.2.2 Obligation of the Operating Company
 - 2.2.3 Obligation of Personnel
- 2.3 Specific Hazards
 - 2.3.1 Hazardous Pumped Liquids
 - 2.3.2 Sharp Edges

3. Transport, Storage and Disposal

- 3.1 Transport
 - 3.1.1 Unpacking and Inspection on Delivery
 - 3.1.2 Lifting
- 3.2 Treatment for Storage
- 3.3 Disposal

4. Layout and Function

- 4.1 Design Details
- 4.2 Labelling
 - 4.2.1 Name Plate
- 4.3 Layout
 - 4.3.1 Verderhus® Stainless Steel Exploded View - Closed
- Coupled Pump
- 4.4 Lubrication

5. Installation and Connection

- 5.1 Preparing for Installation
 - 5.1.1 Checking the Ambient Conditions
 - 5.1.2 Preparing the Installation Site
 - 5.1.3 Preparing the Foundation and Surface
- 5.2 Planning the Pipes
- 5.3 Electrical Connection
 - 5.3.1 Connecting to a Power Supply
 - 5.3.2 Check Rotational Direction

6. Commissioning and Operation

- 6.1 Shutdown and Removal/Storing the Pump
Over Longer periods
- 6.2 Shutdown Without Removal Over Longer Periods
(On-Site Preservation)

7. Inspection, Maintenance and Repairs

- 7.1 Inspections
- 7.2 Maintenance
 - 7.2.1 Cleaning the Pump
- 7.3 Repair
 - 7.3.1 Returning Pump to the Manufacturer
- 7.4 Ordering Spare Parts

8. Troubleshooting

- 8.1 Pump Malfunctions

9. List of Figures and Tables

- 9.1 List of Figures
- 9.2 List of Tables

10. Declaration of Conformity

Appendix A

11. Pump Specifications

- 11.1 Pump Range Specifications
- 11.2 Ambient Conditions
- 11.3 Tightening Torques
- 11.4 Preservatives

Appendix B

12. Impeller Adjustment

Appendix C

13. Disassembly the Spare Parts

- 13.1 Impeller and Mechanical Seal (outer) Removal
- 13.2 Mechanical Seal Removal (Inner)
- 13.3 Spare Parts Replacement

Appendix D

14. Reassembly the Spare Parts

- 14.1 Installation of the Mechanical Seal (Inner)
- 14.2 Installation of the Mechanical Seal (Outer)
- 14.3 Install the Impeller
- 14.4 Install the Intake Socket
- 14.5 Filling the Pump with Oil
- 14.6 Completing the Reassembly of the Spare Parts

1. About this Document

Verderhus® Stainless Steel, series HSB 50-50, 80-50 and 80-80, have been developed according to the latest technology and subject to continuous quality control. These operating instructions are intended to facilitate familiarization with the pump and its designated use. This manual will act as a guide for operating the pump. You are advised to follow these guidelines to operate the pump correctly. These operating instructions do not take local regulations into account; the operator must ensure that such regulations are strictly observed by all, including the personnel responsible for installation.

1.1 Target Groups

Target Groups	Duty
Operating Company	<ul style="list-style-type: none"> ▶ Keep this manual available at the operating site of the pump. ▶ Ensure that personnel read and follow the instructions in this manual and any other applicable documents, especially all safety instructions and warnings. ▶ Observe any additional rules and regulations referring to the system.
Qualified personnel, fitter	<ul style="list-style-type: none"> ▶ Read, observe and follow this manual and the other applicable documents, especially all safety instructions and warnings.

Table 1 Target Groups

1.2 Warnings and Symbols Used in the Manual



Warning	Risk Level	Consequences of disregard
 DANGER	Immediate risk	Death, serious bodily harm
 WARNING	Potential acute risk	Death, serious bodily harm
 CAUTION	Potential hazardous situation	Potential damage to the pump
Note	For information	Possible incorrect use / maintenance of pump

Table 2 Warnings Used in the Manual



Symbol	Meaning
	Safety warning sign in accordance with DIN 4844 - W9 <ul style="list-style-type: none"> ▶ Take note of all information highlighted by the safety warning sign and follow the instructions to avoid injury or death.
▶	Instruction
1., 2.,	Multiple-step instructions
☐	Checklist
→	Cross-reference
	Information

Table 3 Symbols Used in the Manual

2. Safety

 The manufacturer does not accept any liability for damage resulting from disregard of this documentation.

2.1 Intended Use

- ▶ Only use the pump to handle compatible fluids as recommended by the manufacturer (→ Appendix A - 11 Pump Specifications)
- ▶ Adhere to the operating limits
- ▶ Consult the manufacturer regarding any other use of the pump
- ▶ Pumps delivered without a motor must be fitted with a motor in accordance with the provisions of EC Machine Directive 2006/42/EC.

Prevention of misuse (examples)

- ▶ Note the operating limits of the pump with regard to temperature, pressure, flow rate and motor speed (→ Appendix A - 11 Pump Specifications)
- ▶ Do not operate the pump with any inlet/outlet valves closed
- ▶ Only install the pump as recommended in this manual. For example, the following are not allowed:
 - Installing the pump without proper support
 - Installation in the immediate vicinity of extreme hot or cold sources (→ Appendix A - 11 Pump Specifications)

2.2 General Safety Instructions

 Observe the following instructions before carrying out any work.

2.2.1 Product Safety

- These operating instructions contain fundamental information which must be complied with during installation, operation and maintenance. Therefore this operating manual must be read and understood both by the installing personnel and the responsible trained personnel / operators prior to installation and commissioning, and it must always be kept easily accessible within the operating premises of the machine.
Not only must the general safety instructions laid down in this chapter on “Safety” be complied with, but also the safety instructions outlined under specific headings.
- Operate the pump only if it and all associated systems are in good functional condition.
- Only use the pump as intended, be fully aware of safety and risk factors involved and the instructions in this manual.
- Keep this manual and all other applicable documents complete, legible and accessible to personnel at all times.
- Refrain from any procedure or action that would pose a risk to personnel or third parties.
- In the event of any safety-relevant faults, shut down the pump immediately and have the malfunction corrected by qualified personnel.

- The installation of the pump must comply with the requirements of installation given in this manual and any local, national or regional health and safety regulations.

2.2.2 Obligation of the Operating Company

Safety-conscious operation

- ▶ Ensure that the following safety aspects are observed and monitored:
 - Adherence to intended use
 - Statutory or other safety and accident-prevention regulations
 - Safety regulations governing the handling of hazardous substances if applicable
 - Applicable standards and guidelines in the country where the pump is operated
- ▶ Make personal protective equipment available appropriate to operation of the pump.

Qualified personnel

- ▶ Ensure that all personnel tasked with operating the pump have read and understood this manual and all other applicable documents, including the safety, maintenance and repair information, prior to use or installation of the pump.
- ▶ Organize responsibilities, areas of competence and the supervision of personnel.
- ▶ Have all work carried out by specialist technicians only.
- ▶ Ensure that trainee personnel are under the supervision of specialist technicians at all times when working with the pump.

Safety equipment

Provide the following safety equipment and verify its functionality:

- For hot, cold and moving parts: safety guarding should be provided by the operating company.
- For potential build up of electrostatic charge: ensure appropriate grounding if and when required.

Warranty

 The warranty is void if the customer fails to follow any Instruction, Warning or Caution in this document. Verder has made every effort to illustrate and describe the product in this document. Such illustrations and descriptions are however, for the sole purpose of identification and do not express or imply a warranty that the products are merchantable or fit for a particular purpose, or that the products will necessarily conform to the illustration or descriptions.

Obtain the manufacturer's approval prior to carrying out any modifications, repairs or alterations during the warranty period. Only use genuine parts or parts that have been approved by the manufacturer.

For further details regarding warranty, refer to terms and conditions.

2.2.3 Obligation of Personnel



It is imperative that the instructions contained in this manual are complied with by the operating personnel at all times.

- ▶ Pump and associated components:
 - Do not lean or step on them or use as climbing aid
 - Do not use them to support boards, ramps or beams
 - Do not use them as a fixing point for winches or supports
 - Do not de-ice using gas burners or similar tools
- ▶ Do not remove the safety guarding for hot, cold or moving parts during operation.
- ▶ Reinstall the safety equipment on the pump as required by regulations after any repair / maintenance work on the pump.

2.3 Specific Hazards

2.3.1 Hazardous Pumped Liquids

Follow the statutory safety regulations when handling hazardous pumped liquids (e.g. hot, flammable, poisonous or potentially harmful).

Use appropriate Personal Protective Equipment when carrying out any work on the pump.

2.3.2 Sharp Edges

Pump parts, such as the shims and impellers, can be sharp

- Use protective gloves when carrying out any work on the pump

3. Transport, Storage and Disposal

3.1 Transport

 Always transport the pump in a stable position and ensure that the pump is securely attached to the pallet.

3.1.1 Unpacking and Inspection on Delivery

1. Report any transport damage to the manufacturer/distributor immediately.
2. Retain the pallet if any further transport is required.

3.1.2 Lifting

DANGER

Death or crushing of limbs can be caused by falling loads!

1. Use lifting gear appropriate for the total weight to be transported.
2. Make sure the pump and accessories are lifted and moved by qualified lifting personnel equipped with suitable lifting gear.
3. Do not stand under suspended loads.
4. Use a suitable lifting device to lift the pump and secure the pump as outlined in the following sketch. Take note of the centre of gravity.
5. Never use the electrical cable to lift the pump.
6. Before you lift the pump, ensure that neither the pump, the motor, nor the coupling guard can be moved on the base plate.

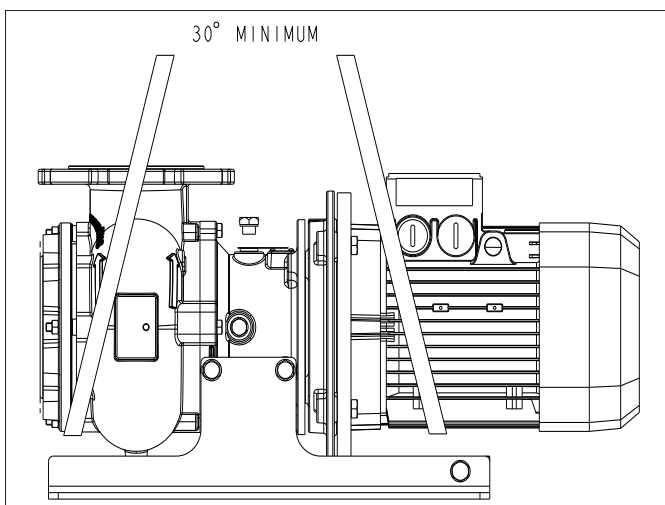

Figure 1 Lifting the Close - Coupled Pump

3.2 Treatment for storage

1. Unpainted steel surfaces should be coated with rust inhibitor and the pump should be stored in a dry, dust free environment not exceeding +5 to 60°C (+40 to 140°F). (→ Appendix A - 11.1.2 Ambient conditions)
2. Close all openings with blanks, plugs or plastic covers.
3. Make sure the storage room meets the following conditions:
 - Dry, humidity not to exceed 85%, non-condensing
 - Out of direct sunlight
 - Frost-free; temperature range +5 to 60°C (+40 to 140°F)
 - Vibration-free; minimize
 - Dust-free; minimize
4. Turn the shaft of the impeller every two weeks to prevent oxidation and rust by rotating the impeller.
5. Ensure the rust inhibitor is fully removed from the pump before putting it back into use.

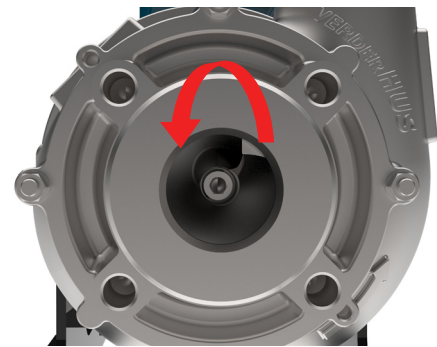



Figure 2 Turn the Shaft of the Impeller

3.3 Disposal

 With prolonged use, pump parts can get contaminated by hazardous pumped liquids to such an extent that cleaning may be insufficient.

WARNING

Risk of poisoning and environmental damage by the pumped liquid or oil!

- ▶ Use suitable personal protective equipment when carrying out any work on the pump.
- ▶ Prior to disposal of the pump:
 - Collect and dispose the lubricant in accordance with local regulations.
 - Collect and dispose of any leaking pumped liquid or oil in accordance with local regulations.
 - Neutralize residues of pumped liquid in the pump.
- ▶ Dispose of the pump and associated parts in accordance with local regulations.

4. Layout and Function

i Verderhus® Stainless Steel screw-channel pumps can transport numerous types of slurry and sludge with minimal wear, thanks to a large, open impeller based on the working principle of a corkscrew. The suction port is a large inlet of at least 50 mm (2 in) which allows the easy passage of pulverized and intact solids. The wide flow path is unsusceptible to clogging, ragging and when pumping long fibrous fluids. The Verderhus® stainless steel range of screw channel pumps is available in several different inlet sizes, ranging from 50 - 80 mm (2-3 in).

4.1 Design Details

i The Verderhus® Stainless Steel range of screw channel pump has an open channel impeller design. Because of the combination of an open channel and the centrifugal forces, high flow rates and efficiencies are accomplished.

4.2 Labelling

4.2.1 Name Plate

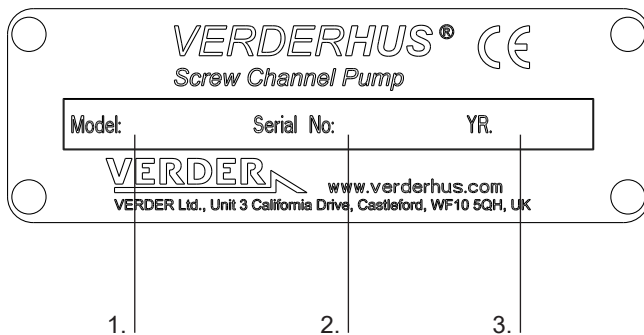

Figure 3 Name Plate

1. Pump Type
2. Serial Number
3. Year of manufacture

i When requesting spares, the model and serial number should always be quoted.

4.3 Layout

4.3.1 Verderhus® Stainless Steel Exploded View - Closed - Coupled Pump

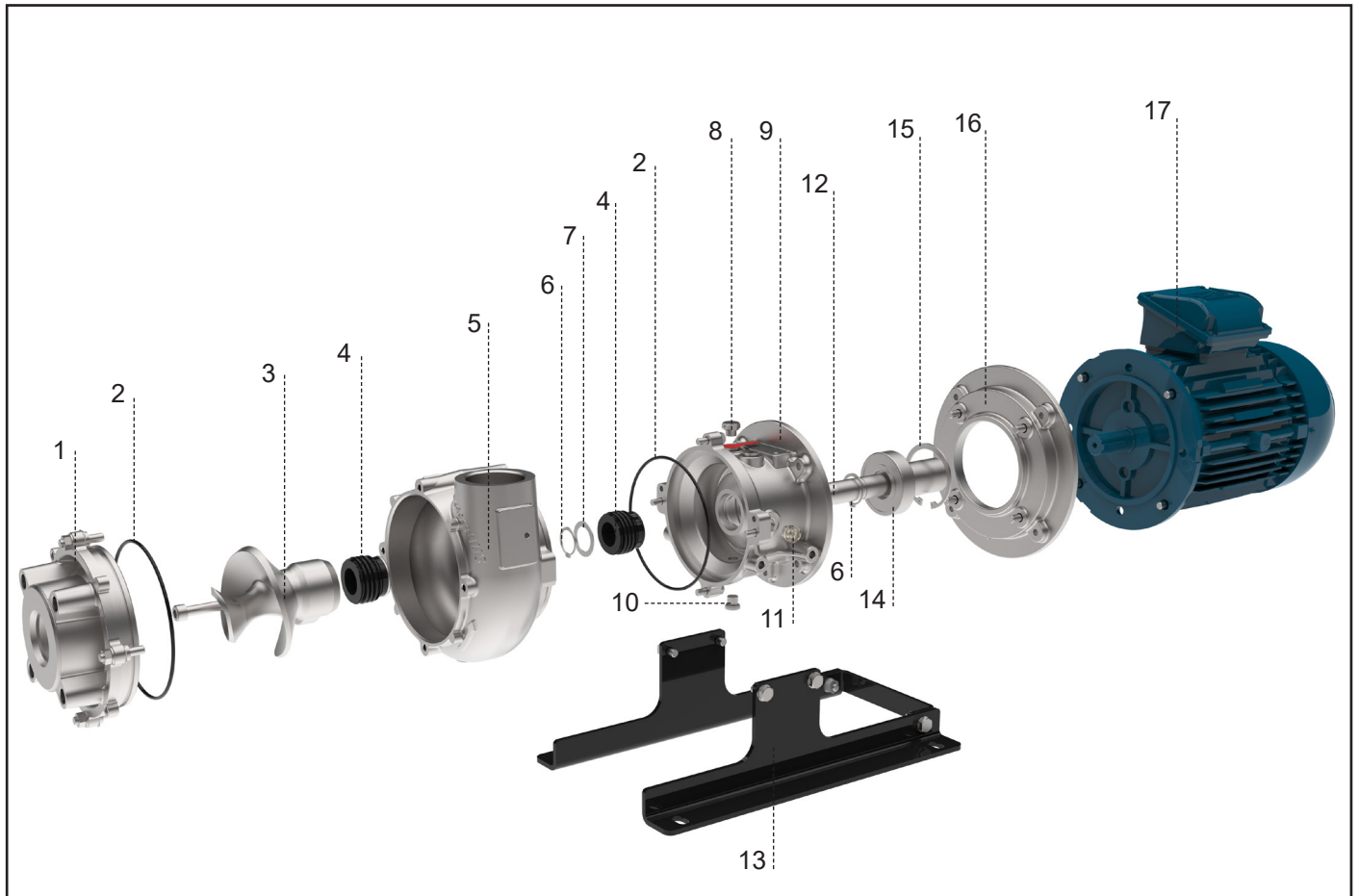

Figure 4 Verderhus® Stainless Steel Exploded View - Closed - Coupled Pump (generic view)

1	Intake Socket	6	External Cir-Clip	11	Oil Sight Plug	16	Transition Flange
2	O-Ring	7	Spacer	12	Shaft	17	Motor
3	Impeller	8	Oil Filler Plug	13	Base Plate		
4	Mechanical Seal (viton)	9	Bearing Housing	14	Bearing		
5	Pump Housing	10	Oil Drain Plug	15	Internal Cir-Clip		

4.4 Lubrication

- ▶ Bearing housing: To be filled at installation with appropriate lubricant if not supplied pre filled. (→10.1.5 Oil and Grease)

5. Installation and Connection

NOTE

Material damage due to unauthorized modification on pump!

- ▶ Do not make any structural modifications to the pump or pump casing
- ▶ Do not carry out any welding work on the pump or pump casing

NOTE

Material damage caused by ingress!

- Do not remove any protective flange covers until immediately before connecting the pipes to the pump

5.1 Preparing for Installation

5.1.1 Checking the Ambient Conditions

1. Make sure that the operating conditions are in accordance with the pump specifications
2. Make sure the required ambient conditions are fulfilled (→ Appendix A - 11.1.2 Ambient conditions)

5.1.2 Preparing the Installation Site

- ▶ Ensure the installation site meets the following conditions:
 - Pump is freely accessible
 - Sufficient space is available for the installation/removal of the pipes and for maintenance and repair work.

5.1.3 Preparing the Foundation and Surface

- ▶ Make sure the foundation and surface meet the following conditions:
 - Level
 - Clean (no oil, dust or other impurities)
 - Capable of bearing the weight of the pump and all operating forces
 - Ensure the pump is anchored securely at all required locations

5.2 Planning the Pipes

1. Always use pipes with a nominal diameter and pressure rating that is greater than or equal to the pump connections.
2. Pipes should be straight for at least 5 diameters to both inlet and outlet before any obstructions are mounted.
3. Include drainage taps in suction and discharge lines at the lowest point.

5.3 Electrical Connection



DANGER

Risk to health due to electric shock!

All electrical work must be carried out by qualified electricians.

1. Connect the motor to the rated power supply. Ensure the correct gland is used and that the earth connection is made and secured.
2. Make sure the motor's direction of rotation is correct.

5.3.1 Connecting to a Power Supply

DANGER

Isolate power supply from the pump before performing the installation.

1. The pump must be installed by a qualified individual.
2. The impeller must be turned by hand to ensure free rotation.
3. The motor cover and cable inlet must be checked for visible damage.
4. Check rotational direction. (→ 5.3.2 Check rotational direction)

5.3.2 Check Rotational Direction

WARNING

Risk of injury and damage to property due to incorrect rotational direction!

► Incorrect rotational direction can result in serious injuries or property damages.

1. The pump must be suspended or placed on its side on the ground.
2. Make sure the impeller's direction of rotation is counter clockwise from suction end.

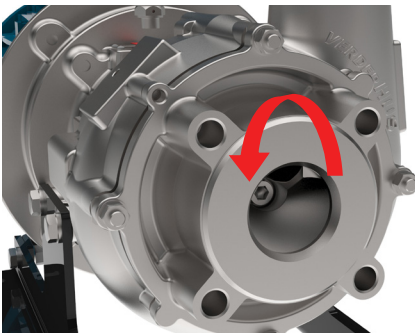

Figure 5 Impeller's Direction of Rotation

NOTE

If the rotational direction is incorrect, switch only the pump's cable conductors or speed with wrong rotational direction at the corresponding starting switch in the control panel.

6. Commissioning and Operation

NOTE

Start-up is not permitted until such time as the pump and all associated and connected devices have been installed and checked, and the safety officer has given the go-ahead for operation to commence.

DANGER

Pumped Medium

The pump may only be operated using the medium specified in the data sheet. The materials used to build the pump are compatible with this medium.

1. Make sure the pump and all levels control are installed correctly.
2. The valves on the suction and discharge side must be completely opened.
3. Ensure the pump is not run dry. (→ 5.3.2 Check rotational direction)

6.1 Shutdown and Removal / Storing the Pump over Longer Periods

1. The parts that come into contact with the pumped medium are to be cleaned and neutralised if necessary.
2. Refer to the storage conditions. (→ 3.2 Treatment for storage)

6.2 Shutdown Without Removal Over Longer Periods (On-Site Preservation)

1. Rinse, and neutralise if necessary, the pump section between the valves.
2. Make sure the pump is drained completely.
3. It is recommended that the impeller is rotated manually or switch the pump on every two weeks to lubricate the mechanical seal.

7. Inspection, Maintenance and Repairs

DANGER

Risk of injury due to running pump!

- ▶ Do not carry out any repair/maintenance work on a pump whilst running.
- ▶ Follow the safety procedures for handling the product being pumped.
- ▶ Decontaminate before handling as per local safety regulations.
- ▶ Appropriate measures must be taken to relieve any pressure build up.

DANGER

Risk of electrocution!

- ▶ Have all electrical work carried out only by qualified electricians.

7.1 Inspections

 The inspection intervals depend on the pump operating cycle.

1. Check at appropriate intervals:
 - No changes in operating conditions
 - The setting distance between impeller and pump housing with feeler gauge after impeller's rotations. (→ Appendix B - 12 Impeller Adjustment)
2. For trouble-free operation, always ensure the following:
 - No leaks
 - No unusual running noises or vibrations
 - Lubricant level (→ Appendix D - 14.4 Filling the Pump with Oil)
 - Temperature is stable

7.2 Maintenance

 VERDER LTD offers customers a service contract, which covers maintenance and repairs to the pump. Contact Customer Service, to request a non-binding offer.

7.2.1 Cleaning the Pump

Make sure that no cleaning agent contaminates the pump bearings and motor.

- ▶ Cover all parts that should not come into contact with cleaning agent.
- ▶ Never spray cold liquids such as water on hot pump parts. The casing may crack if it cools too quickly, and may render the pump unusable.

NOTE

Contact VERDER LTD. before you use a liquid cleaning agent, and confirm that the product that you intend to use is safe. The operator must ensure that the product is safe to use with the pumped medium.

- ▶ Select a suitable method for cleaning the electrical material, and consult a qualified electrician.

7.3 Repair

DANGER

Risk of death due to electric shock!

- ▶ Have all electrical work carried out by qualified electrician only.

WARNING

Risk of injury due to heavy components!

- ▶ Pay attention to the component weight. Lift and transport heavy components using suitable lifting gear.
- ▶ Set down components safely and secure them against overturning or rolling away.

7.3.1 Returning the Pump to the Manufacturer

Obtain prior authorization before repair or return of the pump.

- ▶ Enclose a completed document of compliance when returning pumps or components to the manufacturer.

7.4 Ordering Spare Parts

 For trouble-free replacement in the event of faults, we recommend keeping spare parts available on site.

NOTE

The Verderhus® stainless steel spare parts list contains the following kits:

1. seal kit including o-rings;
2. impeller kit including fasteners.

- ▶ The following information is mandatory when ordering spare parts (→ Name plate):
 - Pump model
 - Year of manufacture
 - Part number / Description of part required
 - Serial number
 - Quantity

8. Troubleshooting

8.1 Pump malfunctions

If malfunctions occur which are not specified in the following table or cannot be traced back to the specified causes, please consult the manufacturer.

Possible malfunctions are identified and respective cause and remedy are listed in the table.

Malfunction								Potential Cause	Recommended Solution ¹⁾
No flow	Motor overloaded	Low flow	Low discharge pressure	Vibration level high	Overheating	Iregular pressure	Oil chamber overflows		
X	-	X	X	-	-	-	-	closed inlet	<ul style="list-style-type: none"> ▶ check suction valve setting ▶ check for blockages ▶ DO NOT RUN IN THIS CONDITION
X	-	-	-	-	-	-	-	closed discharge	<ul style="list-style-type: none"> ▶ check discharge valve setting ▶ DO NOT RUN IN THIS CONDITION
X	-	-	-	-	-	-	-	motor not running	▶ check wiring
-	-	X	X	-	-	-	-	motor direction	▶ check wire connections are correct
-	-	X	X	-	-	-	-	NPSH exceeded	▶ check suction conditions including pipe work and any associated equipment
-	-	X	-	-	X	-	-	low suction head	▶ check pressures and adjust as required
-	-	X	-	-	X	-	-	high discharge head	▶ check pressures and adjust as required
-	-	X	-	-	X	-	-	low cooling oil level	▶ check oil level and address any shortage
-	-	X	-	-	X	-	-	dirt covering pump	▶ clean
-	-	-	X	-	-	-	-	discharge valve	▶ close down to reinstate pressure
-	-	X	X	X	-	-	-	cavitation	▶ increase suction head; can suction valve be opened up
-	X	-	-	X	X	-	-	duty too high	▶ reconsider impeller choice
-	X	-	-	X	X	-	-	bearing failure	▶ stop pump and repair
-	X	X	-	-	-	X	-	pumped media changed	▶ incorrectly specified impeller for media
-	-	-	-	-	X	-	-	fluid temperature too high	▶ add cooling
-	-	-	-	-	-	-	X	seal leaking	▶ stop pump and repair
-	-	-	-	X	-	-	-	impeller rubbing	▶ stop pump and repair

¹⁾ Make sure the pipe sizes are correct for the pump and installation.

Table 4 Troubleshooting



9. List of Figures and Tables

9.1 List of Figures

Figure 1	Lifting the Pump	3.1.2
Figure 2	Turn the Shaft of the Impeller	3.2
Figure 3	Name Plate	4.2.1
Figure 4	Verderhus® Stainless Steel Exploded View - Closed - Coupled Pump (generic view)	4.3
Figure 5	Impeller's Direction of the Rotation	5.3.2

9.2 List of Tables

Table 1	Target Groups	1.1
Table 2	Warnings Used in the Manual	1.2
Table 3	Symbols Used in the Manual	1.2
Table 4	Troubleshooting	8
Table 5	Declaration of Conformity	10

Appendix A

11 Technical Specifications

11.1 Pump Range Specifications

Size	Value
Max. flow rate	72 m ³ /h (317 GPM)
Max. delivery pressure	20 mwc (65 ft.wc)
Temperature of pumped liquid	< 100 °C (210 °F)
Dimensions	→ refer pump datasheet

Table 1 Pump Range Specifications

11.2 Ambient conditions

 Operation under any other ambient condition would require approval from the manufacturer

Operating conditions

- Ambient temperature -5 °C to +45 °C (-40 to +100 °F)
- Relative humidity (non-condensing) – long-term ≤ 85 %
- Setup height above sea level ≤ 1000 m (320 ft)

Storage conditions

- Ambient temperature 0 to +60°C (+30 to +140°F)
- Relative humidity (non-condensing) – long-term ≤ 85 %

11.3 Tightening Torques

 Tightening torques should be applied at the following torque values:

Fastener Size	Torque Value (Nm)			
	Steel - 8.8	Steel - 12.9	A2 - 70 SS	A4 - 70 SS
M8	23	41	22	22
M10	45	81	43	43
M12	82	142	74	74
M16	204	350	189	189
M20	383	685	370	370

Table 2 Pump Fastener Tightening Torques

11.4 Preservatives

 Use e.g. RUST-BAN 335 or similar preservatives on bare metal.

11.5 Oil and Grease

 Recommended lubricants

Bearings: MULTIPURPOSE Grease
Mechanical seal: PETROLEUM Jelly
 Shell Omala S4 GX 150 H1
 Mobil SHC CIBUS 150 H1
 Renolin CLP GEAR OIL 150*

Pump Size	Amount of Oil
50-50	0.4 Litres
80-50	0.4 Litres
80-80	0.4 Litres

*Verder recommends using Renolin CLP GEAR OIL 150.

Table 3 Recommended Oil and Grease

Appendix B

12 Impeller Adjustment

Check the setting distance between impeller and pump housing with feeler gauge after impeller's rotations.

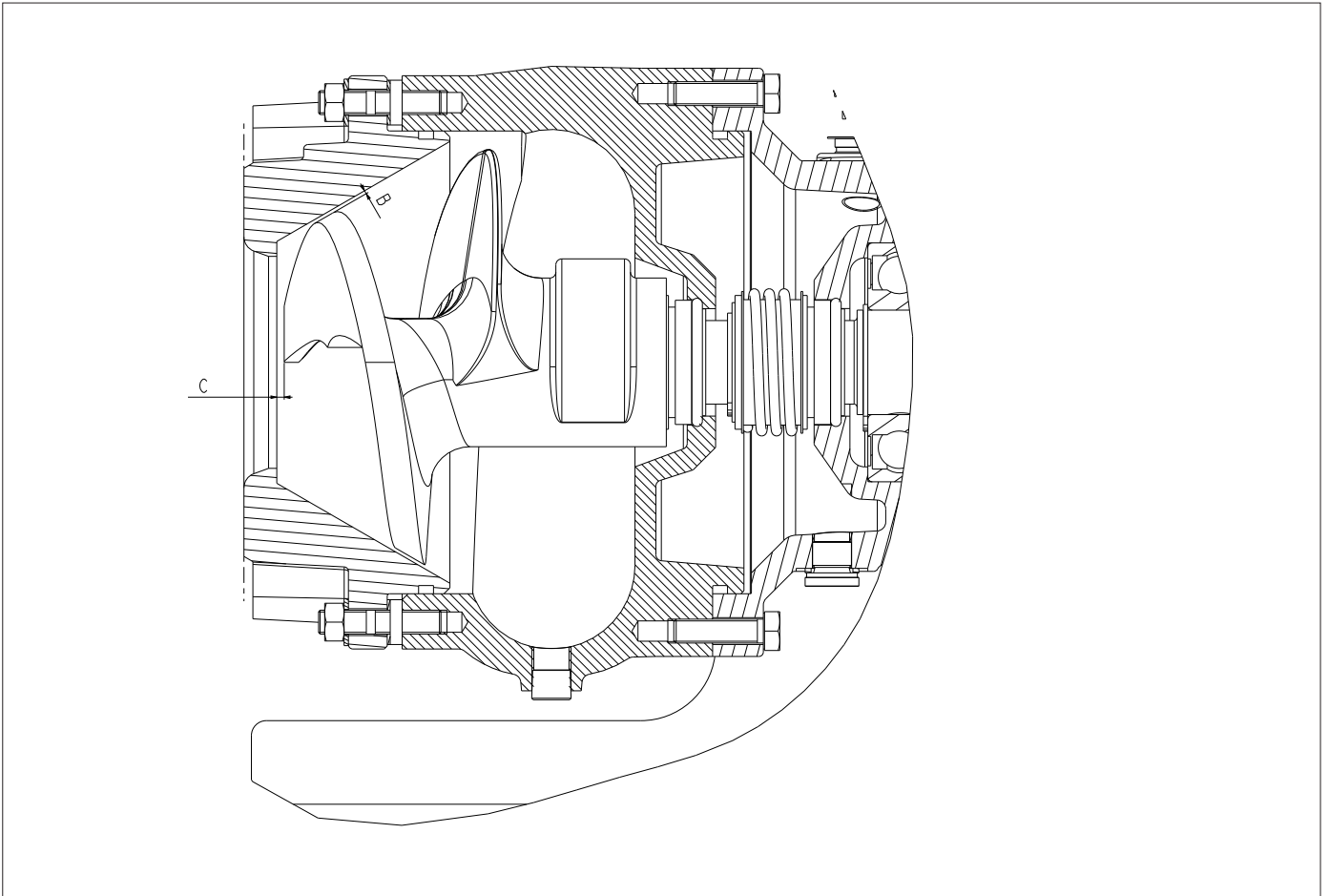

Figure 1 Impeller Setting

Pump Type	B	C
HS50-50	1	1 - 3
HS80-50	1	1 - 3
HS80-80	1	1 - 3

Table 1 Impeller Setting

Appendix C

13 Disassembly the Spare Parts

13.1 Impeller and Mechanical Seal (outer) Removal

DANGER

Risk of death due to electric shock!

- ▶ Always isolate the power supply before working on the pump.
- ▶ System secured against being switched back on again.
- ▶ Make sure the power supply cable never gets in contact with water during the pump servicing.

WARNING

Risk of injury due to heavy components!

- ▶ Pay attention to the component weight. Lift and transport heavy components using suitable lifting gear.
- ▶ Set down components safely and secure them against overturning or rolling away.

1. Draining the oil.

WARNING

Slip hazard due to spill oil!

- ▶ Care must be taken when the oil is drained into a container.
- ▶ Dispose of used oil in accordance with local laws and good environmental practices.

2. Remove the drain plug (item 1).

3. Drain the oil into a suitable container.

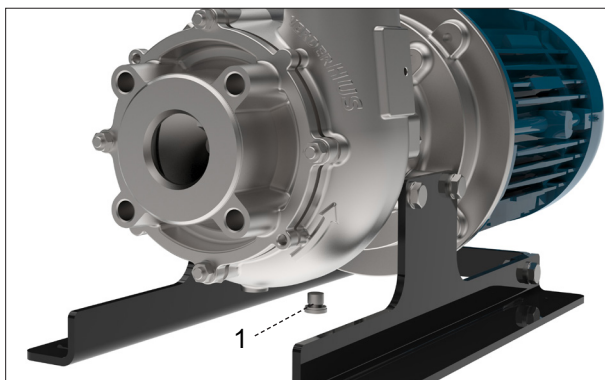

Figure 1 Draining the oil

4. Remove the intake socket (item 2) and the o-ring (item 3).
5. Remove the screws (item 4), using 2 Pry Bars or similar from the two sides ease the impeller from the shaft.

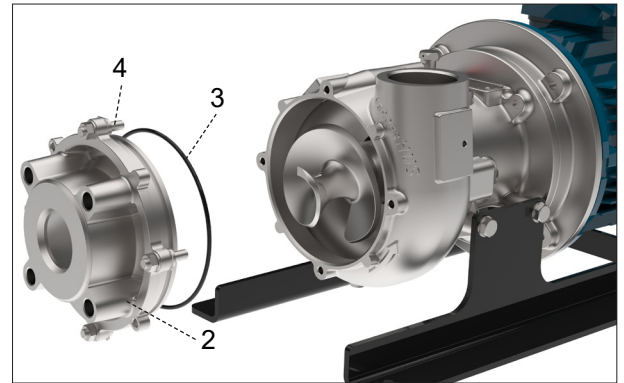

Figure 2 Remove the Intake Socket

6. Untighten the screw (item 5) to remove the impeller (item 6).

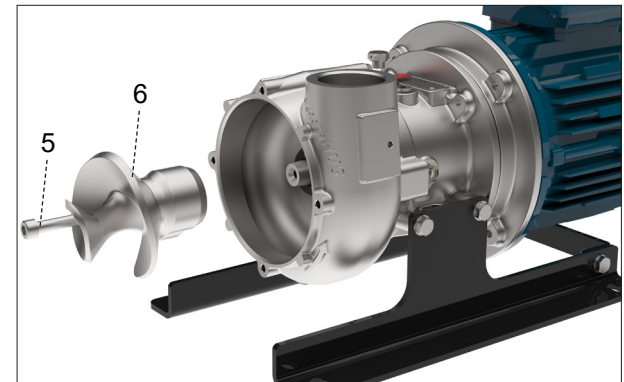

Figure 3 Remove the Impeller

7. Slide out the rotating ring (item 7) and stationary ring (item 8).
8. The mechanical seal (outer) is removed.

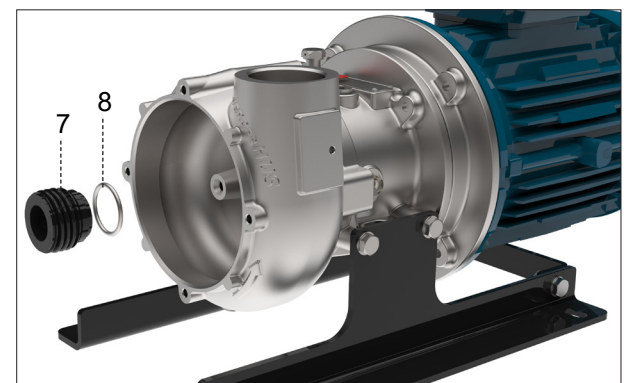

Figure 4 Remove the Mechanical Seal (outer)

13.2 Mechanical Seal Removal (Inner)

1. Remove the pump housing (item 9).

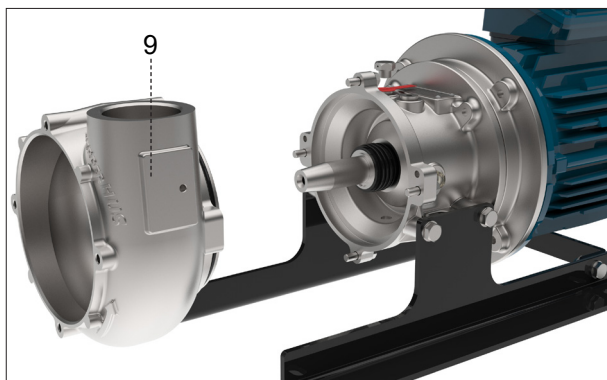

Figure 5 Remove the Pump Housing

2. Remove the cir-clip (item 10) and support washer (item 11).
3. Slide out the rotating ring (item 12) and stationary ring (item 13).
4. The mechanical seal (inner) is removed.

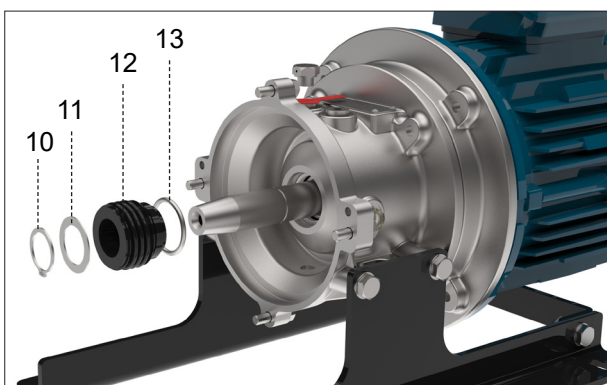



Figure 6 Remove the Mechanical Seal (inner)

13.3 Spare Parts Replacement

-  For trouble-free replacement in the event of faults, we recommend keeping spare parts available on site.

NOTE

The Verderhus® stainless steel spare parts list contains the following kits:

1. seal kit including o-rings;
2. impeller kit including fasteners.

► The following information is mandatory when ordering spare parts (→ Name plate):

- Pump model
- Year of manufacture
- Part number / Description of part required
- Serial number
- Quantity

Appendix D

14 Reassembly the Spare Parts

14.1 Installation of the Mechanical Seal (Inner)

DANGER

Risk of death due to electric shock!

- ▶ Always isolate the power supply before working on the pump.
- ▶ System secured against being switched back on again.
- ▶ Make sure the power supply cable never gets in contact with water during the pump servicing.

WARNING

Risk of cracking or chipping the ceramic seal face!

- ▶ Care must be taken when reassembly the stationary ring to avoid cracking or chipping the ceramic seal face.
- ▶ Apply Petroleum Gel to the stationary ring (item 2).
- ▶ Use a plastic tube for applying pressure to the stationary ring surface to seat it correctly in the seal housing.

1. Press the stationary ring (item 2).
2. Slide rotating ring (item 1) onto drive shaft and locate the seal faces.

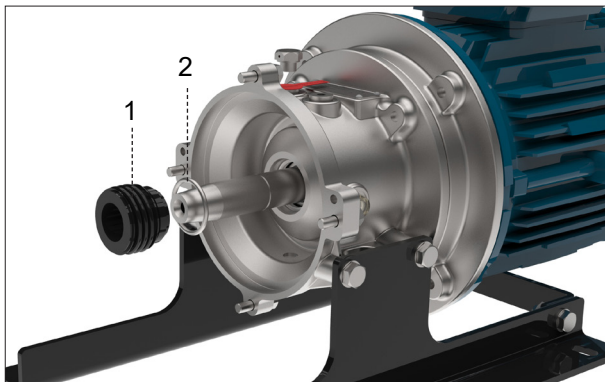

Figure 1 Install the Mechanical Seal (inner)

3. Fit the support washer (item 3) and the cir-clip (item 4). Make sure the cir-clip locates in the correct position.

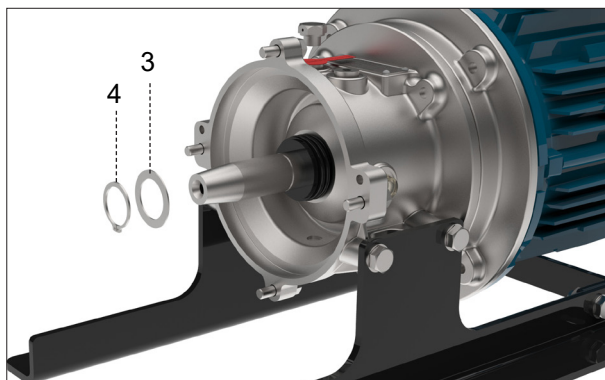

Figure 2 Fit the Support Washer and Cir-Clip

4. Attach the o-ring (item 6) to the housing.
5. Install the pump housing (item 5).

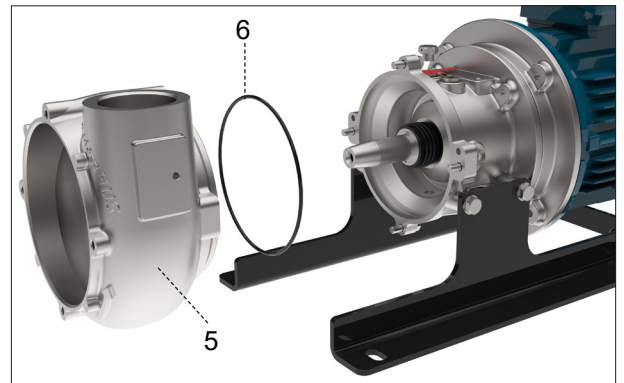

Figure 3 Install the Pump Housing

5. Tighten the screws.
(→ Appendix A - 11.3 Tightening Torques)

14.2 Installation of the Mechanical Seal (Outer)

DANGER

Risk of death due to electric shock!

- ▶ Always isolate the power supply before working on the pump.
- ▶ System secured against being switched back on again.
- ▶ Make sure the power supply cable never gets in contact with water during the pump servicing.

WARNING

Risk of cracking or chipping the ceramic seal face!

- ▶ Care must be taken when reassembly the stationary ring to avoid cracking or chipping the ceramic seal face.
- ▶ Apply Petroleum Gel to the stationary ring (item 7).
- ▶ Use a plastic tube for applying pressure to the stationary ring surface to seat it correctly in the oil-cup housing.

1. Press the stationary ring (item 7).
2. Slide rotating ring (item 6) onto drive shaft and locate the seal faces.

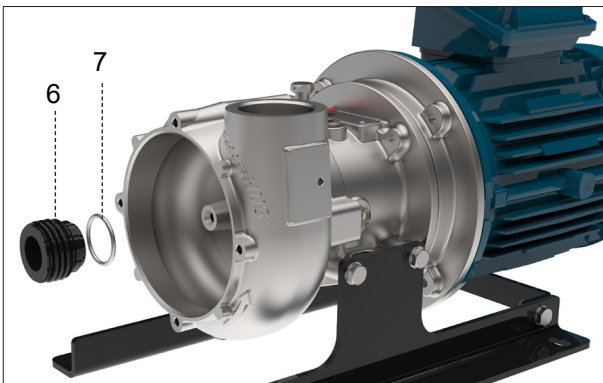

Figure 4 Install the Mechanical Seal (outer)

14.3 Install the Impeller

WARNING

Risk of injury due to heavy components!

- ▶ Pay attention to the component weight. Lift and transport heavy components using suitable lifting gear.
- ▶ Set down components safely and secure them against overturning or rolling away.

1. Attach the impeller (item 8) to the drive shaft.
2. Fix the impeller with a screw (item 9) on the top of impeller.

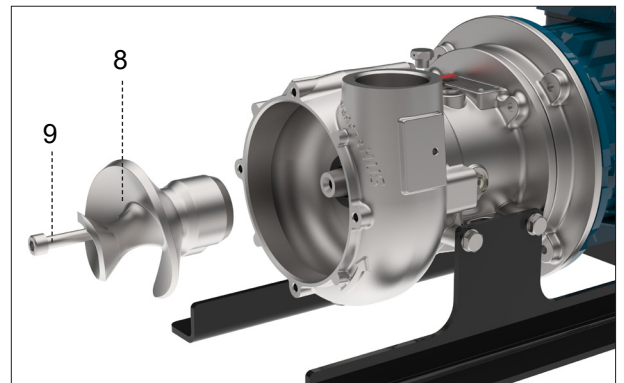

Figure 5 Install the Impeller

14.4 Install the Intake Socket

1. Attach the o-ring (item 10) to the intake socket.
2. Attach the studs (item 12) with the spacers (item 13) to the intake socket (item 11). Add grease on the studs.
3. Fit 4 mm wide spacer (item 14). Set and shim the impeller correctly. (→ see Appendix B - 12 Impeller Adjustment)

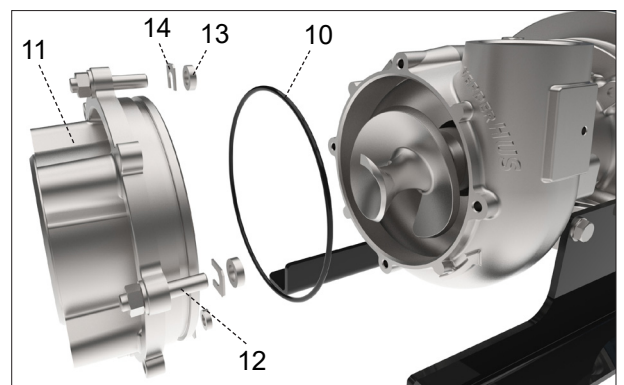



Figure 6 Install the Intake Socket

14.4 Filling the Pump with Oil

 The safety data sheets are available from the manufacturer for compatibility check.

1. Provide a suitable container to collect spilt oil.
2. Refill the bearing housing with the correct grade and quantity of oil. (→ Appendix A - 11.5 Oil and Grease)
3. Fix the oil filler plug (item 15).
4. Check the level of oil through the oil sight plug (item 16).

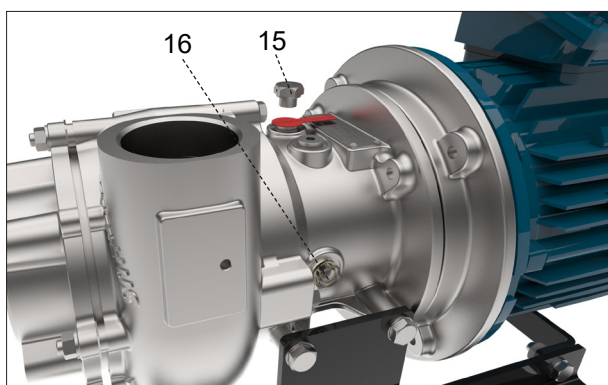

Figure 7 Filling the Pump with Oil

14.5 Completing the Reassembly of the Spare Parts

After completing the installation and before switching on the pump, carry out the following steps:

1. Check that all previously loosened threaded connections are tight (→ Appendix A - 11.3 Tightening Torques).
2. Check that all previously removed protective devices and covers have been replaced properly.
3. Check that all tools, materials and other equipment used have been removed from the work area.
4. Make sure that the work area was cleaned as per local safety regulations.
5. Make sure the pump and all levels control are installed correctly. (→ 5 Installation and Connection)