

# Verderflex VF100

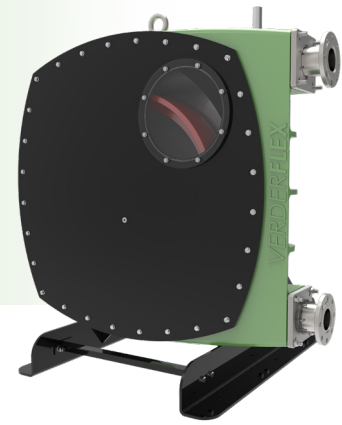

VERDERFLEX®

Description	Material	Paint Detail
Pump Housing	Cast Iron (GG25)	Green Powder Coated
Front Cover	Carbon Steel with Perspex Inspection Window	Powder Coated
Rotor	Cast Iron (GG25)	
Rotor Shoes	Aluminium (6082T6)	
Port Flange	Carbon Steel sheradised screw-on flange in accordance with either DIN PN16 DN100 or ANSI 150# 4" or JIS10K 100mm	
Inserts	Stainless Steel (316L) Options: Polypropylene, PVDF Inserts*	
Mounting Frame	Carbon Steel	Powder Coated
Lubricant	Verderlube - Glycerine based compound** Verdersil - Silicone oil***	
Hose	Natural Rubber (NR) Options: Nitrile Buna Rubber (NBR) Ethylene Propylene Diene Monomer (EPDM), and Hypalon® (CSM)	
Typical Pump Unit Weight	4998 - 5249 lbs	

\* Temperature Limit for PP insert is 95°F and for PVDF insert is 176°F.

\*\* Temperature Limit for Verderlube is 122°F.

\*\*\* Suitable for application above 122°F, but subject to maximum temperature limit of the hose and applications involving strong oxidising agents and nitrogenous compounds.

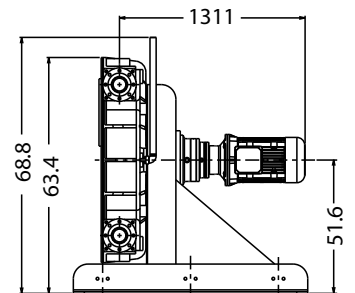
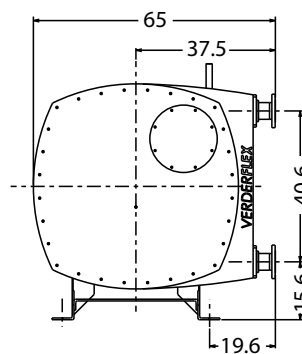
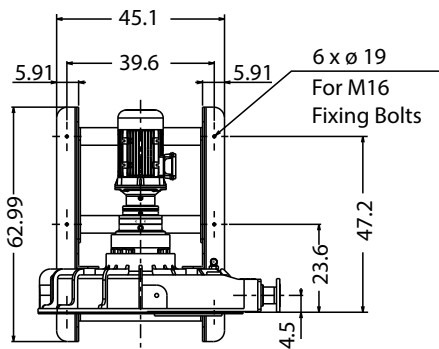

All dimensions are in inches.  
All dimensions and weights are for guidance only.



# Verderflex VF100

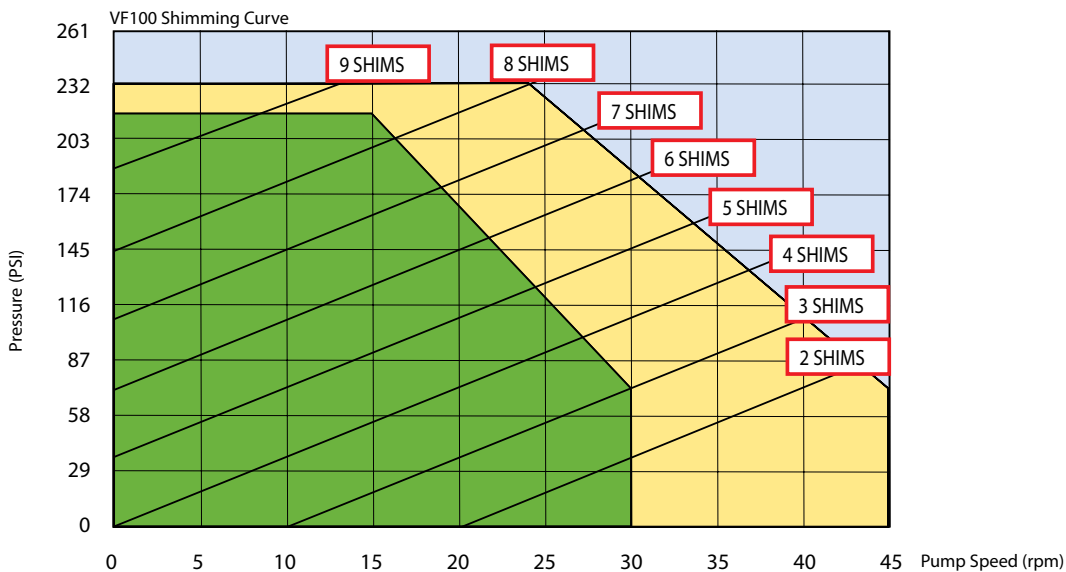
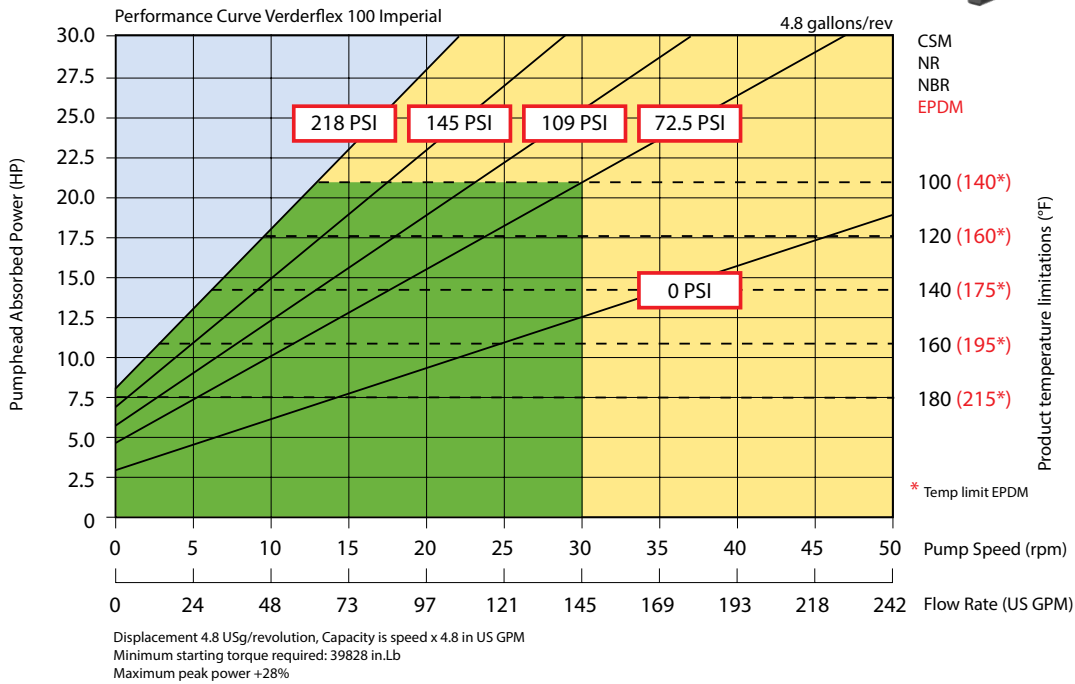
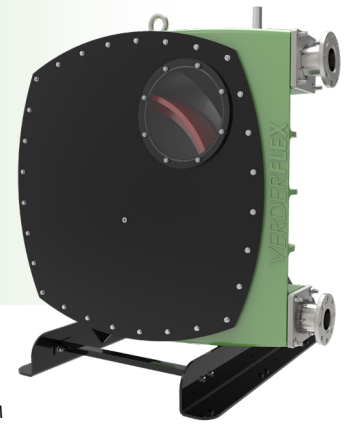

Continuous use (SP) Standard Pressure Rotor

Intermittent use max. 1 hour running min. 1 hour stopped

For product temperatures above 149°F and/or viscosity above 2000 mPas use one shim less than shown

Flows are typical and were measured with water at 68°F with no suction lift or discharge pressure. Actual flows will vary according to suction conditions, discharge pressure and normal component production tolerances.

Find your local supplier  
at [www.verderflex.com](http://www.verderflex.com)

For construction installation and floor mounting drawings  
please contact your local authorised Verderflex® distributor.

**VERDER**  
passion for pumps