

Verder HI-CLEAN VA-H40 and VA-H50 Diaphragm Pumps

819.0418

Rev. J
EN

For use in sanitary applications. For professional use only.

See page 4 for model numbers, descriptions, and compliance approvals.

8 bar (0.8 MPa, 120 psi) Maximum Fluid Working Pressure

8 bar (0.8 MPa, 120 psi) Maximum Air Input Pressure



Important Safety Instructions. Read all warnings and instructions in this manual. Save these instructions.

See page 2 for Table of Contents.

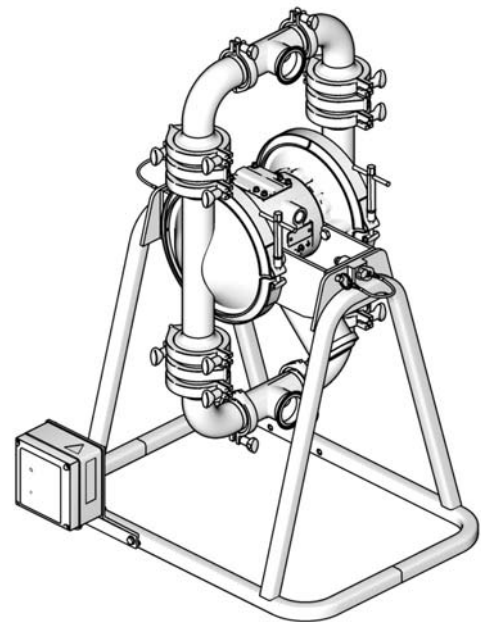

T18760b

Contents

Pump Configuration	3	Service	18
Available Verder HI-CLEAN Configurations	4	Repairing the Air Valve	18
VA-H40	4	Check Valve Repair	21
VA-H50	4	Standard Diaphragm Repair	23
Warnings	5	Overmolded Diaphragm Repair	26
Installation	7	Bearing and Air Gasket Removal	28
General Information	7	Parts Drawing, Fluid Section	30
Leak Detection System	7	Parts List, Fluid Section	31
Tighten Clamps Before First Use	7	Pump Configuration	31
Stand	7	Inlet and Outlet	31
Grounding	8	Diaphragm Material	32
Mountings	8	Parts Drawing, Air Section and Stand	34
Air Line	9	Parts List, Air Section and Stand	35
Fluid Suction Line	9	Air Section - All Models	35
Fluid Outlet Line	9	Leak Detector and Pump Stand	35
Typical Installation	10	Kit 819.0583 Hinge Repair Kit	35
Changing the Orientation of the Fluid Inlet and Outlet Ports	11	Kit 819.0584 Quick-Release Pin Repair Kit . . .	35
Air Exhaust Ventilation	12	Accessories	36
Operation	13	819.0517 Leak Detector 36	
Pressure Relief Procedure	13	VA-H50 Conversion Kits	36
Sanitizing the Pump Before First Use	13	819.0580 3A Approved Ball Check Conversion Kit	36
Starting and Adjusting the Pump	13	819.0581 Flapper Valve Conversion Kit	36
Pump Shutdown	13	819.0578 Sanitary Ball Check Conversion Kit . .	36
Maintenance	14	Model VA-H40 Dimensional Drawing	37
Lubrication	14	Model VA-H40 Technical Data	38
Flushing	14	Model VA-H40 Performance Chart	39
Routine Cleaning of Product Contact Section of Pump	14	Model VA-H50 Dimensional Drawing	40
Tightening Connections	14	Model VA-H50 Technical Data	41
Preventive Maintenance Schedule	15	Model VA-H50 Performance Chart	42
Troubleshooting	16	Customer Services/Guarantee	47
		Customer Services	47

Pump Configuration

Sample Configuration Number: VA-H40 SS SE TF TO T5 SB

VA-H	40	SS	SE	TF	TO	T5	SB
Pump Model	Size	Fluid Section and Air Section	Seats and O-Rings	Balls	Diaphragms	Connections	Pump Style

NOTE: Some combinations are not possible. For a list of current offerings, please see page 4. Also, please check with your local supplier or the pump configurator on www.verderair.com.

Pump Model	Size	Fluid Section and Air Section Material		Seats and O-Rings	
VA-H	40	SS	Stainless Steel Pump with Stainless Steel Air Section	SE	Stainless Steel seats with EPDM o-rings
	50			ST	Stainless Steel seats with PTFE o-rings







Check Valve Balls		Diaphragm		Connections		Pump Style	
BN	Buna-N ball	BN	Buna-N	T1	TriClamp, 4 in.	SB	Standard Ball
FL	Flapper valve	EO	EPDM Overmolded	T4	TriClamp, 1.5 in.	SF	Standard Flapper
NW	Weighted Neoprene ball	SP	Santoprene	T5	TriClamp, 2 in.	3A	3A Approved
SP	Santoprene ball	TO	PTFE Overmolded	T8	TriClamp 3 in.		
TF	PTFE ball			D4	DIN 11851, 40 mm		
				D5	DIN 11851, 50 mm		
				D8	DIN 11851, 80 mm		
				---	Poultry (no connection)		

Available Verder HI-CLEAN Configurations









Sample Configuration Number: VA-H40 SS SE TF TO T5 SB

VA-H	40	SS	SE	TF	TO	T5	SB
Pump Model	Size	Fluid Section and Air Section	Seats and O-Rings	Balls	Diaphragms	Connections	Pump Style

VA-H40

Tri-Clamp Models		DIN Models		Compliance Approvals
Pump Model	Configurator Number	Pump Model	Configurator Number	
810.0830	VA-H40 SS SE TF EO T5 3A	810.0831	VA-H40 SS SE TF EO D5 3A	 EC 1935/2004  
810.0832	VA-H40 SS SE TF EO T5 SB	810.0833	VA-H40 SS SE TF EO D5 SB	
810.0844	VA-H40 SS SE TF TO T5 SB	810.0845	VA-H40 SS SE TF TO D5 SB	 EC 1935/2004  



VA-H50

Tri-Clamp Models		DIN Models		Compliance Approvals
Pump Model	Configurator Number	Pump Model	Configurator Number	
810.0834	VA-H50 SS SE TF EO T5 3A	810.0835	VA-H50 SS SE TF EO D5 3A	 EC 1935/2004  
810.0838	VA-H50 SS SE TF EO T8 3A	810.0839	VA-H50 SS SE TF EO D8 3A	
810.0840	VA-H50 SS SE SP SP T8 SB	810.0841	VA-H50 SS SE SP SP D8 SB	 
810.0846	VA-H50 SS SE FL SP T8 SF	810.0847	VA-H50 SS SE FL SP D8 SF	
810.0836 810.0889†	VA-H50 SS SE TF TO T8 SB	810.0837	VA-H50 SS SE TF TO D8 SB	 EC 1935/2004  
810.0842	VA-H50 SS SE TF EO T8 SB	810.0843	VA-H50 SS SE TF EO D8 SB	
810.0848	VA-H50 SS SE FL EO T8 SF	810.0849	VA-H50 SS SE FL EO D8 SF	









† DS/EN 10204, Type 3.1

Warnings

The following warnings are for the setup, use, grounding, maintenance, and repair of this equipment. The exclamation point symbol alerts you to a general warning and the hazard symbols refer to procedure-specific risks. When these symbols appear in the body of this manual or on warning labels, refer back to these Warnings. Product-specific hazard symbols and warnings not covered in this section may appear throughout the body of this manual where applicable.

 WARNING	
	<p>FIRE AND EXPLOSION HAZARD</p> <p>Flammable fumes, such as solvent and paint fumes, in work area can ignite or explode. To help prevent fire and explosion:</p> <ul style="list-style-type: none"> • Use equipment only in well ventilated area. • Eliminate all ignition sources; such as pilot lights, cigarettes, portable electric lamps, and plastic drop cloths (potential static arc). • Keep work area free of debris, including solvent, rags and gasoline. • Do not plug or unplug power cords, or turn power or light switches on or off when flammable fumes are present. • Ground all equipment in the work area. See Grounding instructions. • Use only grounded hoses. • Hold gun firmly to side of grounded pail when triggering into pail. • If there is static sparking or you feel a shock, stop operation immediately. Do not use equipment until you identify and correct the problem. • Keep a working fire extinguisher in the work area.
	<p>PRESSURIZED EQUIPMENT HAZARD</p> <p>Fluid from the gun/dispense valve, leaks, or ruptured components can splash in the eyes or on skin and cause serious injury.</p> <ul style="list-style-type: none"> • Follow the Pressure Relief Procedure when you stop spraying and before cleaning, checking, or servicing equipment. • Tighten all fluid connections before operating the equipment. • Check hoses, tubes, and couplings daily. Replace worn or damaged parts immediately.

WARNING

 	<p>EQUIPMENT MISUSE HAZARD Misuse can cause death or serious injury.</p> <ul style="list-style-type: none"> • Do not operate the unit when fatigued or under the influence of drugs or alcohol. • Do not exceed the maximum working pressure or temperature rating of the lowest rated system component. See Technical Data in all equipment manuals. • Use fluids and solvents that are compatible with equipment wetted parts. See Technical Data in all equipment manuals. Read fluid and solvent manufacturer’s warnings. For complete information about your material, request MSDS from distributor or retailer. • Do not leave the work area while equipment is energized or under pressure. Turn off all equipment and follow the Pressure Relief Procedure when equipment is not in use. • Check equipment daily. Repair or replace worn or damaged parts immediately with genuine manufacturer’s replacement parts only. • Do not alter or modify equipment. • Use equipment only for its intended purpose. Call your distributor for information. • Route hoses and cables away from traffic areas, sharp edges, moving parts, and hot surfaces. • Do not kink or over bend hoses or use hoses to pull equipment. • Keep children and animals away from work area. • Comply with all applicable safety regulations.
 	<p>TOXIC FLUID OR FUMES HAZARD Toxic fluids or fumes can cause serious injury or death if splashed in the eyes or on skin, inhaled, or swallowed.</p> <ul style="list-style-type: none"> • Read MSDSs to know the specific hazards of the fluids you are using. • Route exhaust away from work area. If diaphragm ruptures, fluid may be exhausted into the air. • Store hazardous fluid in approved containers, and dispose of it according to applicable guidelines.
	<p>BURN HAZARD Equipment surfaces and fluid that’s heated can become very hot during operation. To avoid severe burns:</p> <ul style="list-style-type: none"> • Do not touch hot fluid or equipment.
  	<p>PERSONAL PROTECTIVE EQUIPMENT You must wear appropriate protective equipment when operating, servicing, or when in the operating area of the equipment to help protect you from serious injury, including eye injury, hearing loss, inhalation of toxic fumes, and burns. This equipment includes but is not limited to:</p> <ul style="list-style-type: none"> • Protective eyewear, and hearing protection. • Respirators, protective clothing, and gloves as recommended by the fluid and solvent manufacturer.

Installation

General Information

- The typical installation shown in FIG. 3, page 10, is only a guide for selecting and installing system components. Contact your Verder representative for assistance in planning a system to suit your needs.
- Reference numbers and letters in parentheses refer to the callouts in the figures and the parts lists on pages 30 - 36.

--	--	--	--	--	--	--

The pump is very heavy (see **Technical Data** on pages 38 and 41 for specific weights). If dropped, the pump may rupture. To avoid serious injury, including from splashing fluid, follow the **Pressure Relief Procedure** on page 13. Have two people lift the pump by grasping the outlet manifold securely, or use appropriate lifting equipment.

--	--	--	--	--	--	--

To reduce the risk of serious injury due to burns, insulate and/or label the pump before pumping hot fluids.

Leak Detection System

NOTE: A leak detection system is included with all

approved pumps. See manual 819.0661 included with the leak detector for installation instructions.

Tighten Clamps Before First Use

After you unpack the pump, and before you use it for the first time, check all clamps, and tighten as necessary.

Stand

NOTE: See pages 34 and 35 for parts.

1. Place the stand assembly on a level surface.
2. Mount the pump securely to the stand brackets using bolts provided.

--	--	--	--	--	--	--

Keep clear of moving parts.

NOTE: To drain or service the pump, pull on the quick-release pins (638e, one on each side) to allow the pump to rotate while still securely mounted to the bracket.

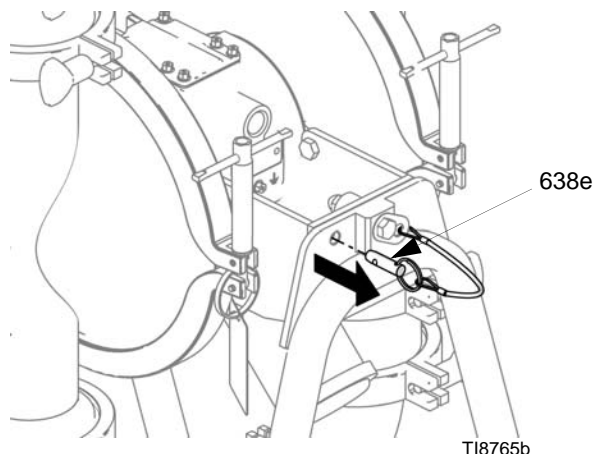





FIG. 1: Quick-release pins for pump rotation

Grounding

						
<p>The equipment must be grounded to reduce the risk of static sparking. Static sparking can cause fumes to ignite or explode. Grounding provides an escape wire for the electric current.</p>						

- Pump:* Connect a ground wire and clamp as shown in FIG. 2. Loosen the grounding screw (W). Insert one end of a 12 ga (1.5 mm²) minimum ground wire (X) behind the grounding screw and tighten the screw securely. Connect the clamp end of the ground wire to a true earth ground. To order a ground wire and clamp, order part number 819.0157.

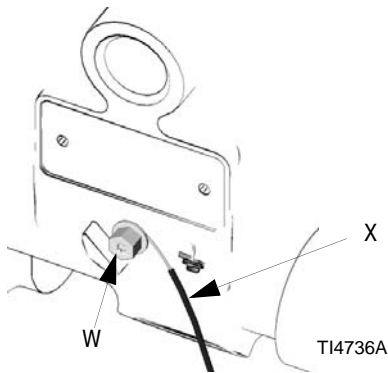

FIG. 2: Ground Wire Connection

- Air and fluid hoses:* Use only grounded hoses with a maximum of 150 m (500 ft) combined hose length to ensure grounding continuity.
- Air compressor:* Follow the manufacturer's recommendations.
- Fluid supply container:* Follow the local code.





Mountings

NOTICE
<p>Ventilate to a remote area. The pump exhaust air may contain contaminants that can contaminate the fluid supply. See Air Exhaust Ventilation, page 12.</p>





- Be sure the mounting surface can support the weight of the pump, hoses, and accessories, as well as the stress caused during operation.
- For all mountings, be sure the pump is bolted directly to the mounting surface.
- For ease of operation and service, mount the pump so the air valve cover, air inlet, and fluid inlet and outlet ports are easily accessible.

Air Line

1. Install the air line accessories as shown in FIG. 3. Mount these accessories on the wall or on a bracket. Be sure the air line supplying the accessories is grounded.
 - a. Install an air regulator (C) and gauge to control the fluid pressure. The fluid outlet pressure will be the same as the setting of the air regulator.
 - b. Locate one bleed-type master air valve (B) close to the pump and use it to relieve trapped air. Be sure the valve is easily accessible from the pump and located downstream from the regulator.

						
<p>Trapped air can cause the pump to cycle unexpectedly, which could result in serious injury, including splashing in the eyes or on the skin, injury from moving parts, or contamination from hazardous fluids.</p>						

- c. Locate the other master air valve (E) upstream from all air line accessories and use it to isolate them during cleaning and repair.
- d. The air line filter (F) removes harmful dirt and moisture from the compressed air supply.

						
<p>In the step below, do not connect the quick-disconnect coupler (D) on the air hose to the mating fitting on the pump until you are ready to operate the pump. Connecting the coupler too early can result in unintentional operation of the pump, leading to serious injury from moving parts, splashing fluid in the eyes or on the skin, and contact with hazardous fluids.</p>						

2. Install a grounded, flexible air hose (A) between the accessories and the 1/2 npt(f) pump air inlet (M). Use a minimum 3/8 in. (9.5 mm) ID air hose. Screw an air line quick disconnect coupler (D) onto the end of the air hose (A), and screw the mating fitting into the pump air inlet snugly.





Fluid Suction Line

1. Use flexible, grounded fluid hoses (G) where possible.
2. For best sealing results, use an appropriate tri-clamp-style or DIN-style sanitary gasket of a flexible material such as EPDM, Buna-N, fluoroelastomer, or silicon.

NOTE: The customer supplied DIN 11851 gasket must be of the type described in 3A bulletin 2011-3 to be compliant with the 3A sanitary standards. Two examples of gaskets that are compliant are the Siersema Componenten System (S.K.S.) B.V., Netherlands, and the ASEPTO-STAR k-flex from Keiselmann GmbH, Germany. Consult the 3A bulletin for more information.

3. If the fluid inlet pressure to the pump is more than 25% of the outlet working pressure, the ball check valves will not close fast enough, resulting in inefficient pump operation. Excessive inlet fluid pressure also will shorten diaphragm life. Approximately 0.21-0.34 bar (0.02 - 0.03 MPa, 3 - 5 psi) should be adequate for most materials.
4. See the **Technical Data** on pages 38 and 41 for maximum suction lift (wet and dry). For best results, always install the pump as close as possible to the material source.

Fluid Outlet Line

						
<p>A fluid drain valve (J) is required to relieve pressure in the hose if it is plugged. The drain valve reduces the risk of serious injury, including splashing in the eyes or on the skin, or contamination from hazardous fluids when relieving pressure.</p>						

1. Use flexible, grounded fluid hoses (L) where possible.
2. For best sealing results, use an appropriate tri-clamp-style or DIN-style sanitary gasket of a flexible material such as EPDM, Buna-N, fluoroelastomer, or silicon. For 3A applications, see **NOTE** under **Fluid Suction Line**.
3. Install a fluid drain valve (J) near the fluid outlet. See FIG. 3.
4. Install a shutoff valve (K) in the fluid outlet line.

Typical Installation

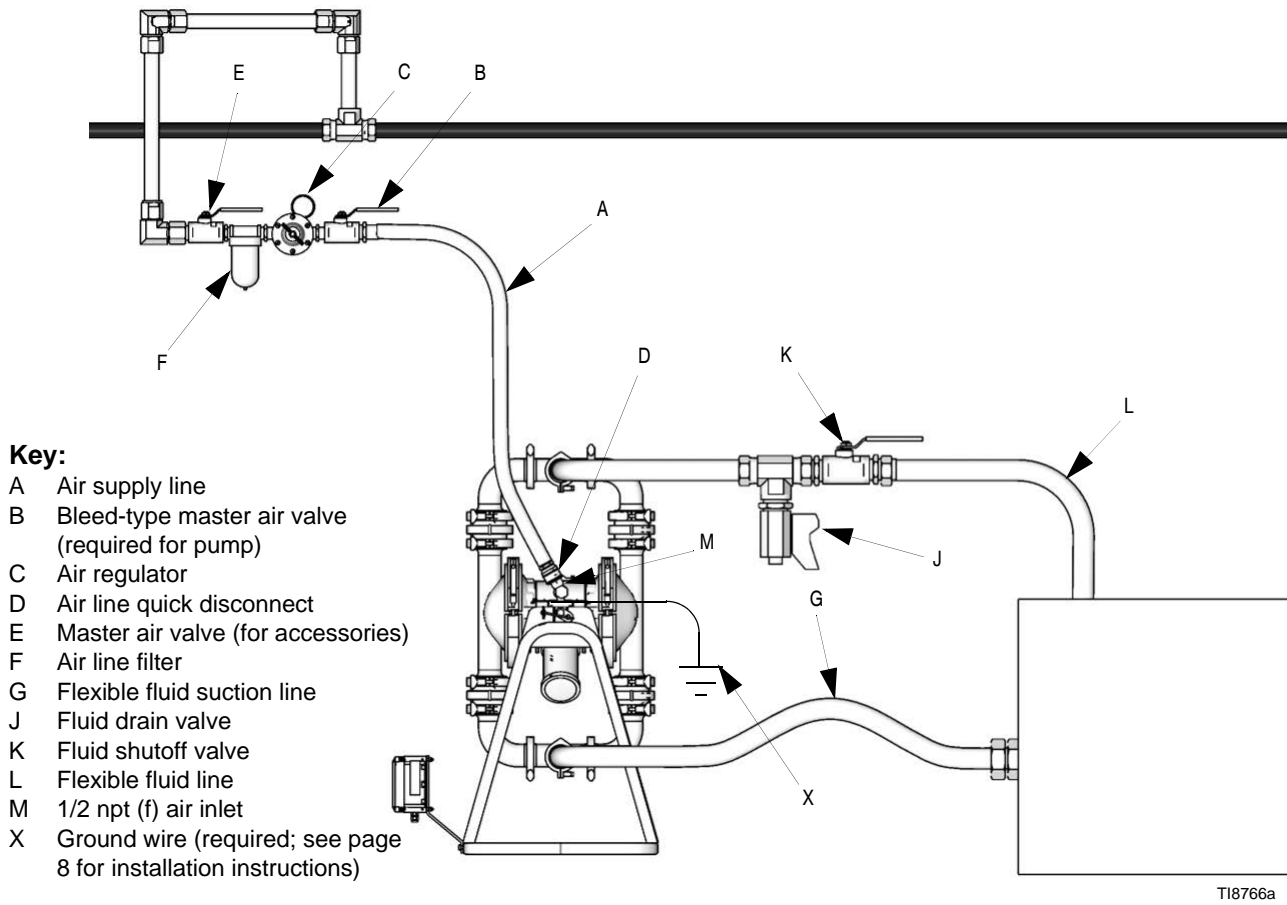

FIG. 3: Typical Floor-Mount Installation

Changing the Orientation of the Fluid Inlet and Outlet Ports

The pump is shipped with the ports facing the same direction. To reorient the ports into any position:

1. Remove the clamps (130) holding the inlet and/or outlet tee to the elbows.
2. Rotate the manifold tee (339) and reattach. Install the clamps (130) and tighten handtight.

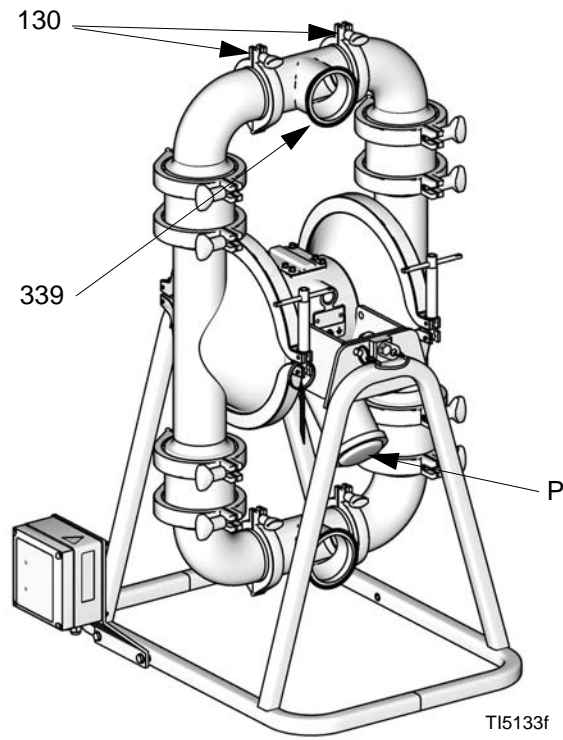





FIG. 4: Orientation of Fluid Ports

Air Exhaust Ventilation

						
---	---	---	--	--	--	--

To avoid serious injury from explosion or hazardous fluids:

- be sure the system is properly ventilated for your type of installation.
- vent the exhaust away from people, animals, food handling areas, and all sources of ignition
- place an appropriate container at the end of the air exhaust line to catch fluid. If a diaphragm ruptures, the fluid being pumped will exhaust with the air. See FIG. 5.

NOTE: The air exhaust port is 3/4 npt(f). Do not restrict the air exhaust port. Excessive exhaust restriction can cause erratic pump operation.

To provide a remote exhaust:

1. Remove the muffler (P) from the pump air exhaust port. See FIG. 5.
2. Install a grounded air exhaust hose (T) and connect the muffler (P) to the other end of the hose. The minimum size for the air exhaust hose is 19 mm (3/4 in.) ID. If a hose longer than 4.57 m (15 ft) is required, use a larger diameter hose. Avoid sharp bends or kinks in the hose.
3. Place a grounded container (U) at the end of the air exhaust line to catch fluid in case of a diaphragm rupture. See FIG. 5.

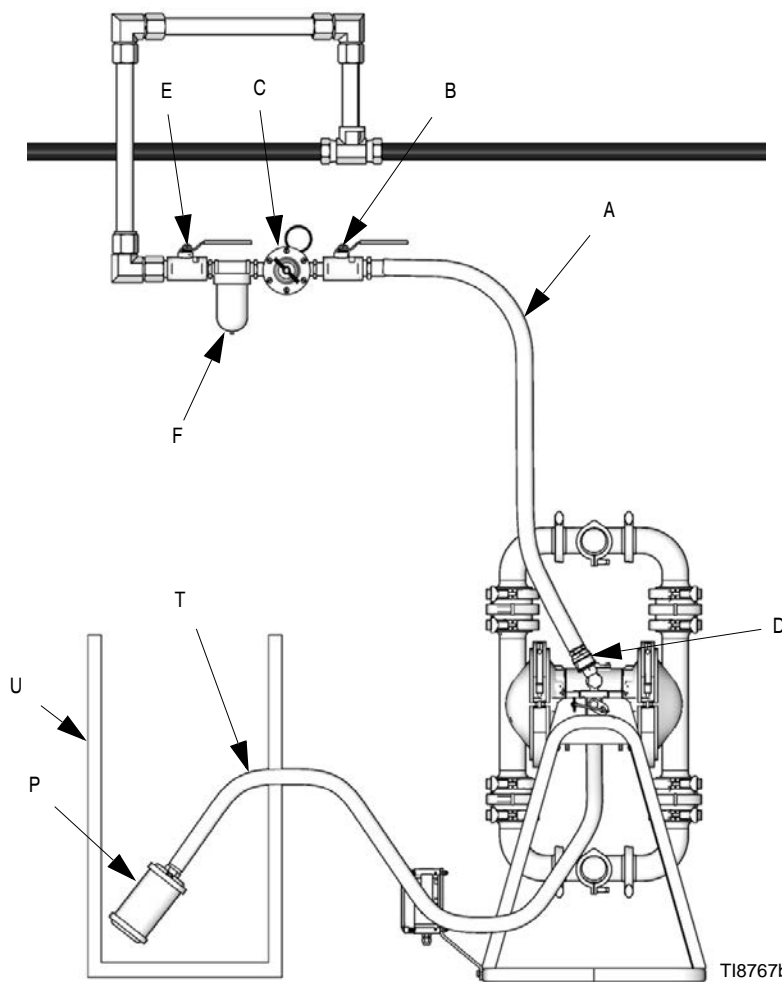

Key:

- A Air supply line
- B Bleed-type master air valve (required for pump)
- C Air regulator
- D Air line quick disconnect
- E Master air valve (for accessories)
- F Air line filter
- P Muffler
- T Grounded air exhaust hose
- U Container for remote air exhaust

FIG. 5: Venting Exhaust Air

Operation

Pressure Relief Procedure



Follow the Pressure Relief Procedure whenever you see this symbol.



The equipment stays pressurized until pressure is manually relieved. To reduce the risk of serious injury from pressurized fluid or splashing fluid, follow this procedure whenever you stop pumping and before cleaning, checking, or servicing equipment.

1. Shut off the air to the pump.
2. Open any available outbound fluid valve to relieve fluid pressure from the pump.
3. If fluid is still in the outbound fluid lines, isolate this fluid as follows:
 - a. Close the outbound fluid valves.
 - b. Slowly remove the fluid connections from the pump, and have a container ready to catch any fluid that runs out.

Sanitizing the Pump Before First Use



NOTE: The pump was built and tested using a food grade lubricant.

It is the user's responsibility to properly sanitize the pump before first use. As necessary, follow the steps under **Starting and Adjusting the Pump** below, under **Flushing** on page 14, or under **Disassembly** in the **Service** section on pages 21, 23, and 26.

Starting and Adjusting the Pump

1. Be sure the pump is properly grounded. See **Grounding**, page 8.
2. Check connections to be sure they are tight. Tighten fluid inlet and outlet connections securely.
3. Place the suction tube (if used) in fluid to be pumped.

NOTE: If fluid inlet pressure to the pump is more than 25% of the outlet working pressure, the ball check valves will not close fast enough, resulting in inefficient pump operation.

4. Place the end of fluid hose (L) into an appropriate container.
5. Close the fluid drain valve (J).
6. Back out the air regulator (C) knob, and open all bleed-type master air valves (B, E).
7. If the fluid hose has a dispensing device, hold it open while continuing with the following step.
8. Slowly increase air pressure with the air regulator (C) until the pump starts to cycle. Do not exceed the maximum operating air pressure as listed in the Technical Data section on pages 38 and 41. Allow the pump to cycle slowly until all air is pushed out of the lines and the pump is primed.

Pump Shutdown

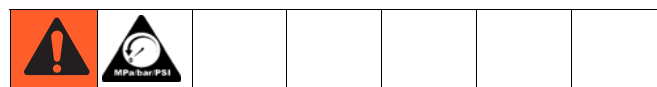

At the end of the work shift, relieve pressure.

Maintenance

Lubrication

The air valve is designed to operate unlubricated. If lubrication is desired, every 500 hours of operation (or monthly) remove the hose from the pump air inlet and add two drops of machine oil to the air inlet.

NOTICE
Do not over-lubricate the pump. Oil is exhausted through the muffler and could contaminate your fluid supply or other equipment. Excessive lubrication can also cause the pump to malfunction.

Flushing



Insert suction tube into cleaning solution. Open air regulator to supply low pressure air to the pump. Run the pump long enough to thoroughly clean the pump and hoses. Close the air regulator. Remove the suction tube from the cleaning solution and drain pump. Place suction tube in the fluid to be pumped.

Flush the pump often enough to prevent the fluid you are pumping from drying or freezing in the pump and damaging it. Flushing schedule will be based on what the pump is being used for. Use a compatible cleaning solution and always cycle the pump during the entire flushing process.

Always flush the pump and relieve the pressure before storing it for any length of time.

Routine Cleaning of Product Contact Section of Pump

NOTE: The pump and the system should be cleaned in accordance with your state sanitary standard codes and local regulations.

1. Flush the system. See **Flushing** above.
2. Follow the **Pressure Relief Procedure**, page 13.
3. Disassemble the fluid section of the pump and accessories. See **Check Valve Repair**, page 21, and **Standard Diaphragm Repair**, page 23, or **Overmolded Diaphragm Repair**, page 26.

4. Using a brush or other C.O.P. methods, wash all product contact pump parts with an alkaline detergent at the manufacturer's recommended temperature and concentration.
5. Rinse these parts again with water and allow parts to completely dry.
6. Inspect the parts and reclean any soiled parts.
7. Immerse all product contact parts in an approved sanitizer before assembly. Leave the parts in the sanitizer, taking them out only one by one as needed for assembly. See **Check Valve Repair**, page 21, and **Standard Diaphragm Repair**, page 23, or **Overmolded Diaphragm Repair**, page 26.
8. Lubricate the clamps, clamping surfaces, and gaskets with waterproof sanitary lubricant.
9. Circulate the sanitizing solution through the pump and the system prior to use. Cycle the pump as the sanitizing solution is circulated.

Tightening Connections

Before each use, check all hoses for wear or damage, and replace as necessary. Check to be sure all connections are tight and leak-free.

Preventive Maintenance Schedule

Establish a preventive maintenance schedule based on the pump's service history. This is especially important for prevention of spills, leakage, or food contamination due to diaphragm failure.

The following is a list of recommended maintenance procedures and frequencies. Maintenance must be performed by trained personnel per the established schedule.

Task	Operator	Maintenance Person	
	Daily	Weekly	Monthly
Inspect system for leaks	✓		
Depressurize fluid, after operation	✓		
Remove heat from system, after operation	✓		
Inspect diaphragm for wear	✓		
Inspect check valve components for wear	✓		
Check hoses for wear		✓	
Check/tighten fluid connections		✓	
Check/tighten air connections		✓	
Lubricate air valves			✓

Troubleshooting



- Follow the **Pressure Relief Procedure**, page 13, before checking or servicing the equipment.
- Check all possible problems and causes before disassembling the pump.

PROBLEM	CAUSE	SOLUTION
Pump cycles at stall or fails to hold pressure at stall.	Worn check valve balls (541) or seats (233).	Replace. See page 21.
Pump will not cycle, or cycles once and stops.	Air valve is stuck or dirty.	Disassemble and clean air valve. See page 18. Use filtered air.
	Check valve ball (541) severely worn and wedged in seat (233) or manifold.	Replace ball and seat. See page 21.
	Check valve ball (541) is wedged into seat (233), due to overpressurization.	Follow Pressure Relief Procedure , page 13. Disassemble ball check assembly and inspect for damage, see page 21.
	Dispensing valve clogged.	Relieve pressure and clear valve.
	Leak detector has activated a shut-down solenoid	Investigate failure and reset leak detector
Pump operates erratically.	Clogged suction line.	Inspect; clear.
	Sticky or leaking balls (541).	Clean or replace. See page 21.
	Diaphragm ruptured.	Replace. See page 23 (standard) or page 26 (Overmolded).
	Restricted exhaust.	Remove restriction.
Air bubbles in fluid.	Suction line is loose.	Tighten.
	Diaphragm ruptured.	Replace. See page 23 (standard) or page 26 (Overmolded).
	Loose inlet manifold, damaged seal between manifold and seat, damaged gaskets.	Tighten manifold clamps or replace seats or gaskets. See page 21.

PROBLEM	CAUSE	SOLUTION
Leak in inlet or outlet sanitary fitting.	Loose sanitary clamp.	Tighten clamp.
	Damaged or worn gasket.	Replace gasket.
	Misalignment of inlet/outlet hose or pipe.	Use flexible hoses at pump inlet and outlet.
	Gasket does not seal.	Use a standard sanitary gasket of flexible material such as EPDM, Buna-N, fluoroelastomer, or silicon.
Fluid in exhaust air.	Diaphragm ruptured.	Replace. See page 23 (standard) or page 26 (Overmolded).
	Loose diaphragm plate.	Tighten or replace. See page 23 (standard) or page 26 (Overmolded).
Pump exhausts excessive air at stall.	Worn air valve block, plate, pilot block, u-cups, or pilot pin o-rings.	Repair or replace. See page 18.
	Worn shaft seals.	Replace. See page 23 (standard) or page 26 (Overmolded).
Pump leaks air externally.	Air valve cover is loose.	Tighten screws. See page 18.
	Air valve gasket or air cover gasket is damaged.	Inspect; replace. See page 18.
	Air cover clamps are loose.	Tighten clamps.
Pump leaks fluid externally from ball check valves.	Loose manifolds, damaged seal between manifold and seat, damaged gaskets.	Tighten manifold clamps or replace seats or clamps (132). See page 21.
Chattering.	Check balls not seating properly/cleanly due to imbalance between fluid inlet and outlet line sizing. Noise is accentuated with light viscosity fluids.	Reduce size/diameter of inlet line relative to outlet line. Outlet line size should not exceed pump size.

Service

Repairing the Air Valve

Tool Required

- Torque wrench
- Torx (T20) screwdriver or 7 mm (9/32 in.) socket wrench
- Needle-nose pliers
- O-ring pick
- Lithium-based grease

Air Valve Repair Kit 819.0664 is available. Refer to **Parts** on page 35. Parts included in the kit are marked with ♦ symbol. Use all the parts in the kit for the best results.

Disassembly

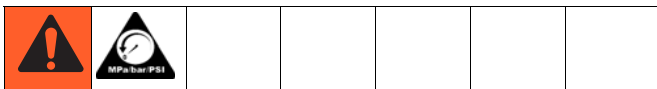

1. Follow the **Pressure Relief Procedure**, page 13.
2. With a Torx (T20) screwdriver or 7 mm (9/32 in.) socket wrench, remove the six screws (103), air valve cover (102), and gasket (104). See FIG. 6.

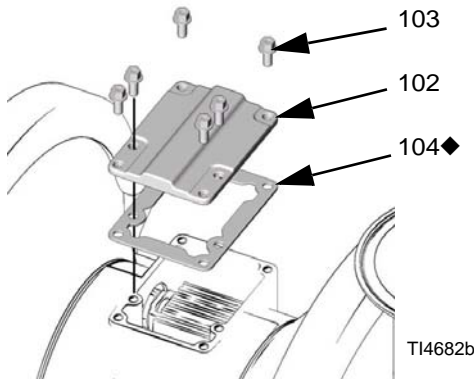

FIG. 6

3. Move the valve carriage (105) to the center position and pull it out of the cavity. Using a needle-nose pliers, pull the pilot block (116) straight up and out of the cavity. See FIG. 7.

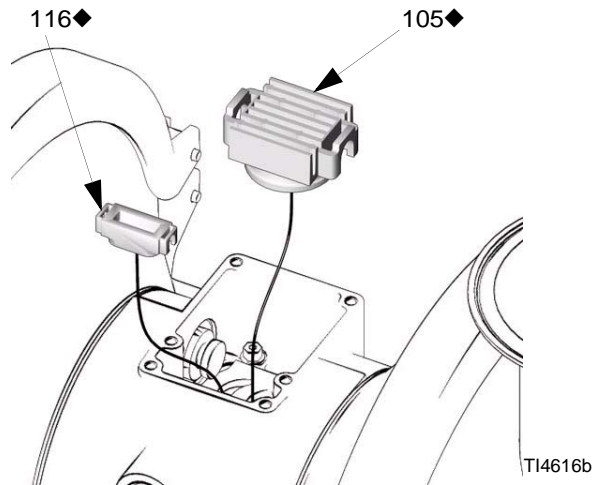

FIG. 7

4. Pull the two actuator pistons (111). Remove the u-cups (110) from the pistons. Pull the pilot pins (114). Remove the o-rings (115) from the pilot pins. See FIG. 8.

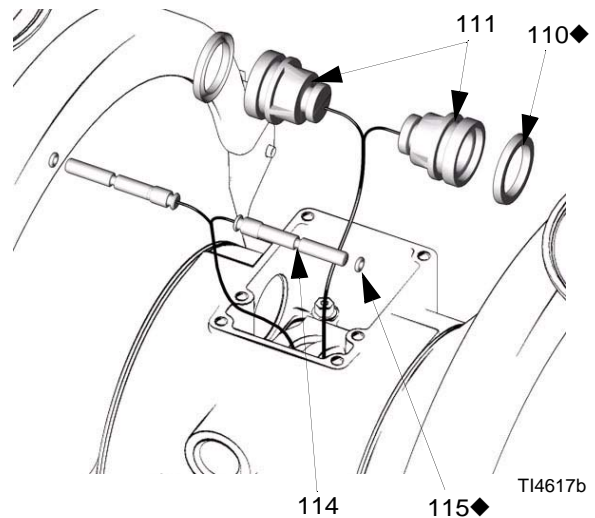

FIG. 8

5. Inspect the valve plate (108) in place. If damaged, use a Torx (T20) screwdriver or 7 mm (9/32 in.) socket wrench to remove the three screws (103). Remove the valve plate (108). See FIG. 9.

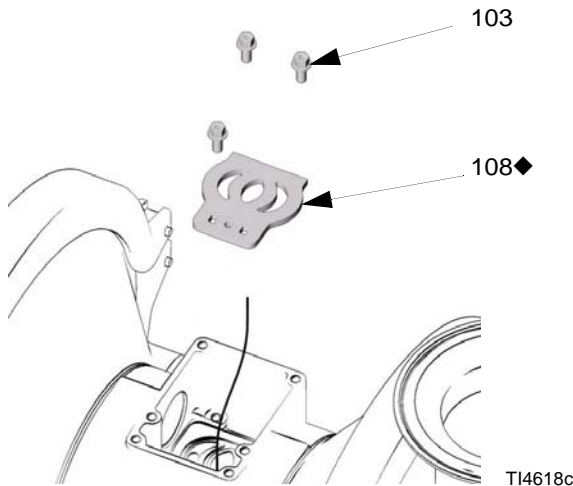

FIG. 9

6. Inspect the bearings (112, 117) in place. See **Parts** on page 35. The bearings are tapered and, if damaged, must be removed from the outside. This requires disassembly of the fluid section. See page 28.
7. Clean all parts and inspect for wear or damage. Replace as needed. Reassemble, page 19.

Reassembly

NOTE: Apply lithium-based grease when instructed to grease. Order part number 819.0184.

1. *If you replaced the bearings (112, 117),* reinstall as explained on page 28. Reassemble the fluid section.
2. Install the valve plate (108) in the cavity, seal down. Install the three screws (103), using a Torx (T20) screwdriver or 7 mm (9/32 in.) socket wrench. Tighten until the screws bottom out on the housing. See FIG. 9.
3. Install an o-ring (115) on each pilot pin (114). Grease the pins and o-rings. Insert the pins into the bearings, **narrow** end first. See FIG. 10.

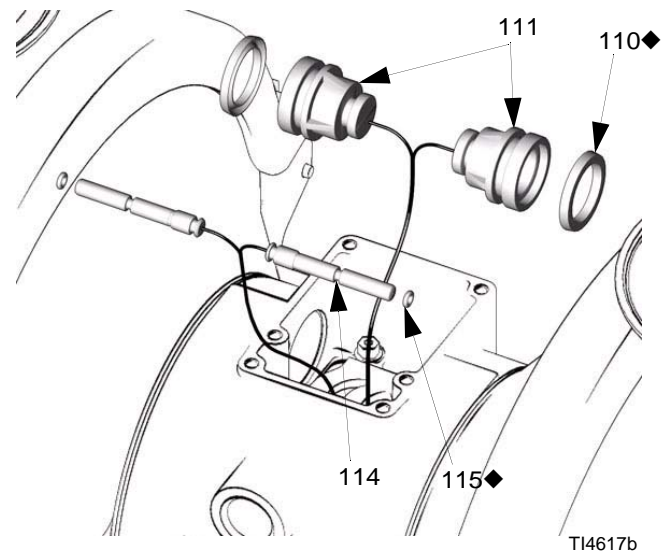

FIG. 10

4. Install u-cups (110) on each actuator piston (111), so the lips of the packings face the **narrow** end of the pistons. See FIG. 10.
5. Lubricate the u-cups (110) and actuator pistons (111). Insert the actuator pistons in the bearings, **wide** end first. Leave the narrow end of the pistons exposed. See FIG. 10.

- Grease the lower face of the pilot block (116) and install so its tabs snap into the grooves on the ends of the pilot pins (114). See FIG. 11.
- Grease the lower face of the valve carriage (105). See FIG. 11.
- Install the valve carriage (105) so its tabs slip into the grooves on the narrow end of the actuator pistons (111). See FIG. 11.

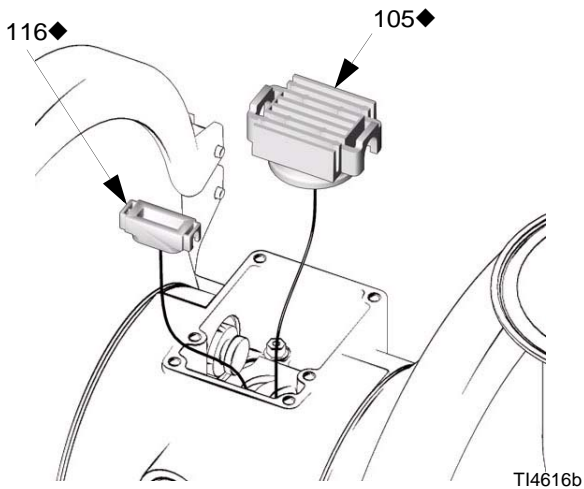

FIG. 11

- Align the valve gasket (104) and cover (102) with the six holes in the center housing (101). Secure with six screws (103), using a Torx (T20) screwdriver or 7 mm (9/32 in.) socket wrench. Torque to 5.7-6.8 N•m (50-60 in-lb). See FIG. 12.

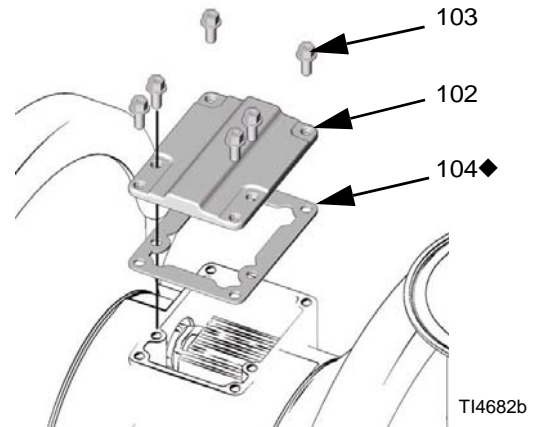

FIG. 12

Check Valve Repair

Disassembly

Reference numbers with an asterisk (*) are replacement parts. For a complete list of replacement parts see **Parts**, page 30 and following.



1. Follow the **Pressure Relief Procedure**, page 13. Disconnect all hoses.
2. Pull the quick release pins and tilt the pump to drain.
3. From the outlet manifold, remove both upper clamps (132a).
4. Remove outlet manifold leaving elbows (128), gaskets (129), clamps (130), and tee (339) assembled.
5. *For 3A Ball Check pumps:* remove ball gasket (240). Remove middle clamp (132c) and ball stop housing (2XA). Remove middle gasket (240) and ball (541). Remove lower clamp (132b), seat (2XB), and gasket (240). Clean all parts and inspect for wear or damage. Replace parts as needed.

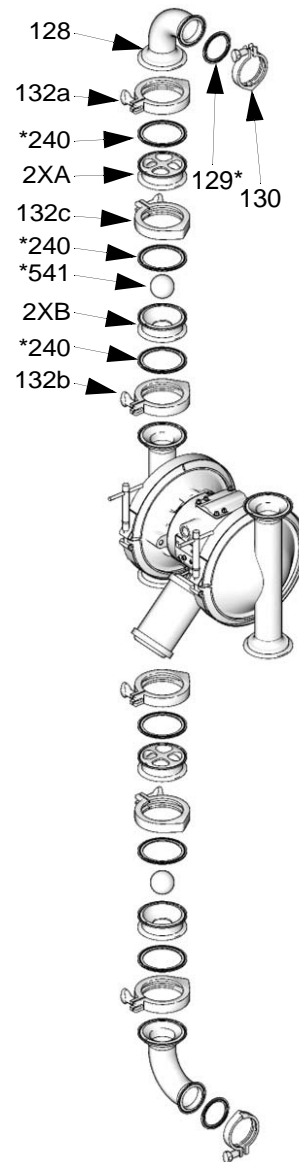

T18768a

FIG. 13: 3A Ball Check Assembly

For Sanitary Ball Check pumps: remove ball gasket (242) and ball (541). Remove lower clamp (132b), seat (233), and gasket (240). Clean all parts and inspect for wear or damage. Replace parts as needed.

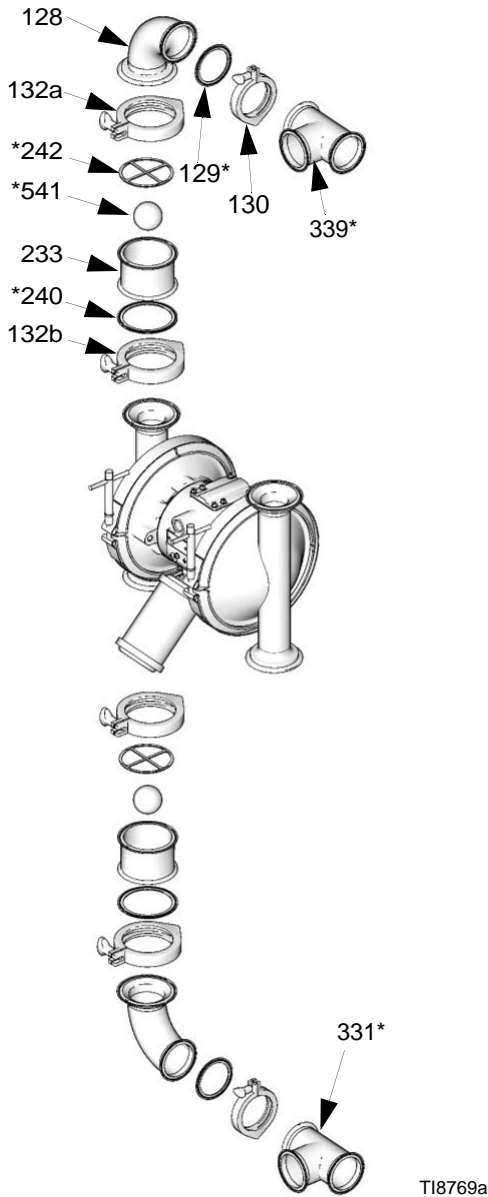

FIG. 14: Sanitary Ball Check Assembly

For Flapper Check pumps: remove gasket (240). Remove middle clamp (132c) and housing (252). Remove middle gasket (240), and flapper valve (251). Remove lower clamp (132b), lower flapper housing (248), and gasket (240). Clean all parts and inspect for wear or damage. Replace parts as needed.

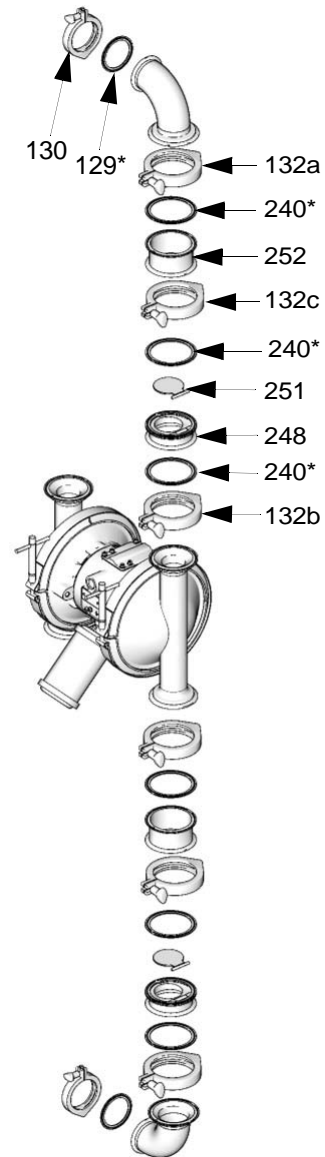

FIG. 15: Flapper Check Assembly

6. Disassemble the outlet manifold. Remove clamps (130), tee (339), gasket (129), and elbow (128). Clean all parts and inspect for wear or damage. Replace parts as needed.
7. Repeat for inlet manifold.

Reassembly

NOTE: Lubricate clamps, clamping surfaces, and gaskets with waterproof, sanitary lubricant.

1. Reassemble inlet and outlet fluid manifolds in reverse order. See step 6. Tighten clamps hand-tight.
2. Reassemble ball or flapper check assembly in reverse order. See step 5. Tighten clamps hand-tight.

NOTE: For flapper check, make sure flapper check (251) is placed properly in housing (248) groove. Ensure that the flapper check moves freely.

Standard Diaphragm Repair

NOTE: See page 26 for overmolded diaphragms, including all 3A diaphragms.

Tools Required

- Torque wrench
- 5/8 in. wrench
- 19 mm open end wrench
- O-ring pick
- Lithium-based grease
- Spanner wrench

Disassembly



1. Follow the **Pressure Relief Procedure**, page 13.
2. Remove the manifolds and disassemble the ball check valves as explained on page 21.
3. Hold fluid covers in place and remove the clamps (135). Pull the fluid covers (234) off the pump.

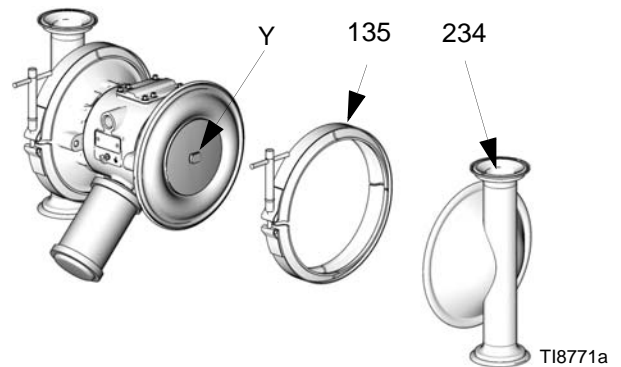

FIG. 16

4. With both fluid covers removed, using two 5/8 in. wrenches hold the wrench flats (Y) on the plates of each diaphragm assembly and loosen. One diaphragm assembly will come free and the other will remain attached to the shaft.
5. Disassemble the free diaphragm assembly.
6. Remove plate (444) with bolt (143) installed, diaphragm (446), backer (447) if present, and plate (445).

8. Inspect the diaphragm shaft (121) for wear or scratches. If it is damaged, inspect the bearings (117) in place. If the bearings are damaged, refer to **Bearing and Air Gasket Removal** on page 28.
9. Reach into the center housing (101) with an o-ring pick and hook the u-cups (110), then pull them out of the housing. This can be done with the bearings (117) in place. See FIG. 24, page 28.
10. Clean all parts and inspect for wear or damage. Replace parts as needed.

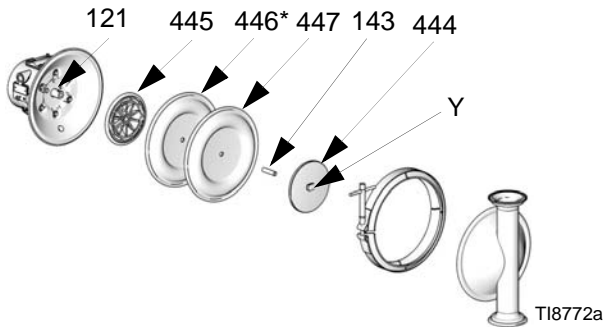

FIG. 17

7. Pull the other diaphragm assembly and the diaphragm shaft (121) out of the center housing (101). Hold the shaft flats with a 19 mm open end wrench, and remove the diaphragm assembly from the shaft. Disassemble the remaining diaphragm assembly.

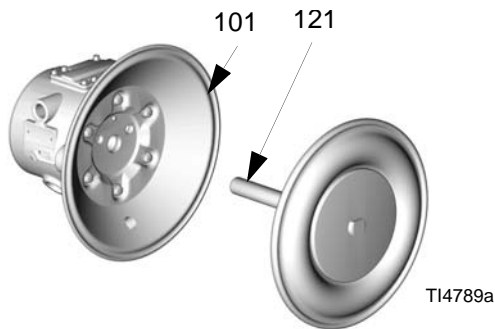

FIG. 18

Reassembly

NOTE: Apply lithium-based grease when instructed to grease. Order part number 819.0184.

1. Install the shaft u-cups (110) so the lips face **out** of the housing (101). Lubricate the u-cups. See **Reassembly**, page 28.
2. Assemble diaphragm (446), backer (447) if present, and plate (445) onto plate (444) with screw (143). Rounded side of plate (445) should face diaphragm. Make sure the side marked AIR SIDE faces the center housing.

NOTE: Thread locker must be applied to screw (143) as shown in FIG. 19 for all diaphragm assemblies.

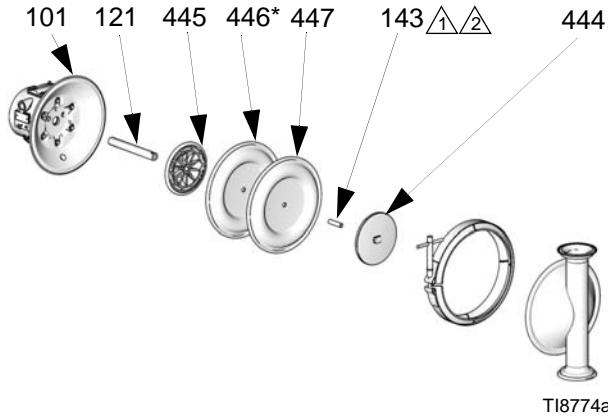

- 1 Apply a high-strength thread locker to attach the screw to the diaphragm plate, if needed.
- 2 Apply a medium-strength thread locker to the shaft side of the screw.

FIG. 19

3. Screw assembled diaphragm assembly into shaft (121) and hand tighten.
4. Grease the length of the diaphragm shaft (121), and slide it through the housing (101).
5. Assemble the other diaphragm assembly to the shaft as explained in step 2.
6. Using a 5/8 in. wrench hold the wrench flats of one diaphragm assembly and torque the other diaphragm to 81-94 N•m (60-70 ft-lb).

NOTE: Waterproof, sanitary lubricant may be applied to the clamp (135) and clamping surface of the cover (234) to ease assembly.

7. Align the fluid covers (234) and the center housing. Secure the covers with the clamps (135) and hand tighten.

NOTE: A food grade anti-seize lubricant can be used on the clamp threads to aid assembly.

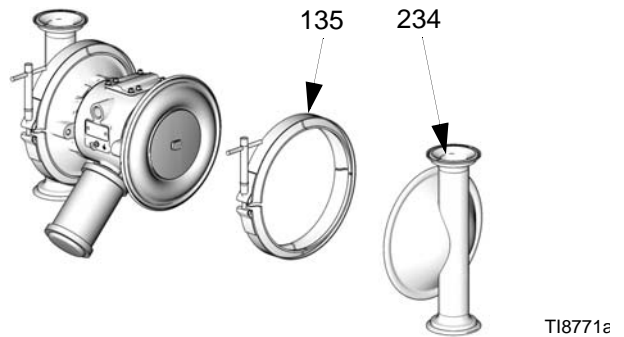

FIG. 20

8. Reassemble the ball check valves and manifolds as explained on page 21.

Overmolded Diaphragm Repair

NOTE: If your pump uses standard diaphragms, see page 23.

Tools Required

- Torque wrench
- 19 mm open end wrench
- O-ring pick
- Lithium-based grease

Disassembly



1. Follow the **Pressure Relief Procedure**, page 13.
2. Remove the manifolds and disassemble the ball check valves as explained on page 21.
3. Remove the clamps (135) holding the fluid covers (234) to the air covers (120). Pull the fluid covers (234) off the pump. See FIG. 21.
4. Once the fluid covers are removed, the diaphragm on the side of the pump which was last pressurized with air will be separated from the center section/air cover. This allows you to grip the diaphragms.
5. Diaphragms are assembled handtight. To loosen, grip both diaphragms securely around the outer edge and rotate counterclockwise. One diaphragm assembly will come free and the other will remain attached to the shaft. Remove the freed diaphragm (446) and air side plate (445).
6. Pull the opposite diaphragm assembly and shaft (121) out of the center housing (101). Hold the shaft flats with a 19 mm open end wrench and remove the diaphragm and air side plate from the shaft.
7. Inspect the diaphragm shaft (121) for wear or scratches. If it is damaged, inspect the bearings (117) in place. If the bearings are damaged, refer to page 28.
8. Reach into the center housing (101) with an o-ring pick and hook the u-cup packings (110), then pull them out of the housing. This can be done with the bearings (117) in place.
9. Clean all parts and inspect for wear or damage. Replace parts as needed.

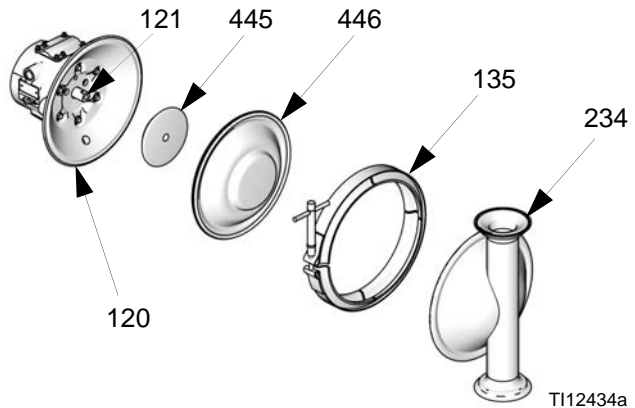
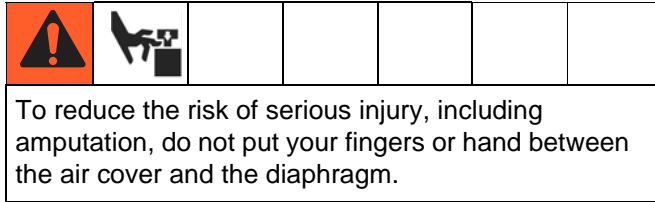

FIG. 21

Reassembly

NOTE: Apply lithium-based grease when instructed to grease. Order part number 819.0184.



1. Install the shaft u-cup packings (110*) so the lips face **out** of the housing (101). Lubricate the packings. See FIG. 24, page 28.
2. Apply high-strength (red) thread locker to attach the bolt (446a) to the diaphragm (446), if needed. Assemble the air side plate (445) onto the diaphragm (446). The wide, radiused side of the plate must face the diaphragm. Apply medium-strength (blue) thread locker to the threads of the diaphragm assembly. Screw the assembly into the shaft (121) hand tight.
3. Grease the length and ends of the diaphragm shaft (121). Insert the shaft/diaphragm assembly into one side of the pump.

NOTE: Turn the pump 90° on the stand for easier fluid cover clamping.

Align the fluid cover (234) and the center housing. Securely tighten the clamp (135).

4. Assemble the other diaphragm assembly to the shaft as explained in step 2. This diaphragm will be lifted off the air cover at this point.
5. Supply the pump with low pressure air (less than 0.5 bar [0.05 MPa, 7 psi]). The diaphragm will very slowly pull onto the air cover (120). Find the pressure that keeps the diaphragm close enough to clamp, but does not let it contact the pilot pin.

NOTICE

Do not deform the diaphragm manually. The diaphragm needs uniform pressure to deform properly.

6. Assemble the fluid cover (234) and clamp (135) so the cover is aligned to the center housing. Tilt pump for easier assembly. Securely tighten the clamp.

NOTE: If the diaphragm contacts the pilot pin and is forced away from the air cover, try Step 5 again. If necessary, return to Step 3.

7. Reassemble the ball check valves and manifolds as explained on page 21.

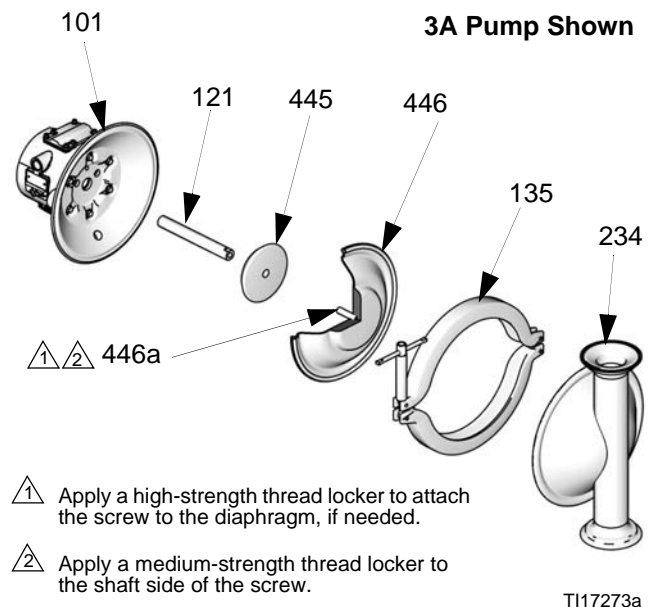

FIG. 22

Bearing and Air Gasket Removal

Tools Required

- Torque wrench
- 10 mm socket wrench
- Bearing puller
- O-ring pick
- Press, or block and mallet

Disassembly

NOTE: Do not remove undamaged bearings.



1. Follow the **Pressure Relief Procedure**, page 13.
2. Remove the manifolds and disassemble the ball check valves as explained on page 21.
3. Remove the fluid covers and diaphragm assemblies as explained on page 23 (standard) or page 26 (Overmolded).

NOTE: If you are removing only the diaphragm shaft bearing (117), skip step 4.

4. Disassemble the air valve as explained on page 18.
5. Using a 10 mm socket wrench, remove the screws (122) holding the air covers (120) to the center housing (101).

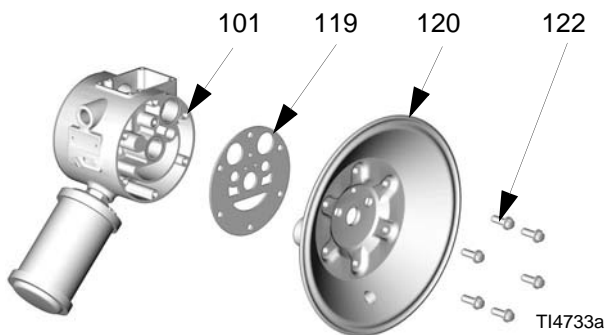

FIG. 23

6. Remove the air cover gaskets (119). Always replace the gaskets with new ones.
7. Use a bearing puller to remove the diaphragm shaft bearings (117), air valve bearings (112) or pilot pin bearings (113). Do not remove undamaged bearings

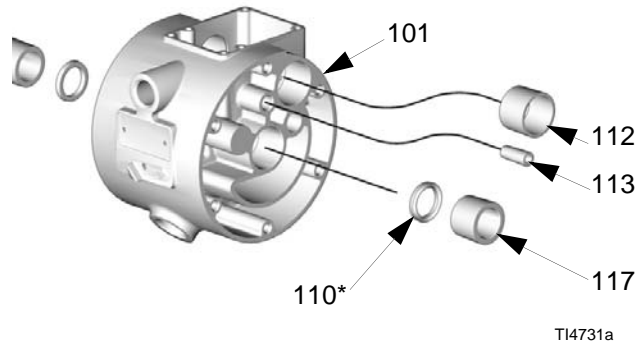

FIG. 24

8. If you removed the diaphragm shaft bearings (117) reach into the center housing (101) with an o-ring pick and hook the u-cups (110), then pull them out of the housing. Inspect the u-cups. See FIG. 24. Replace parts as needed.

Reassembly

NOTE: Adhesive must be applied to the outside surface of the bearing (112) and the inside surface of bore (Z) prior to assembly.

1. Install the shaft u-cups (110) so the lips face **out** of the housing.
2. Insert new bearings (112, 113, and 117) into the center housing (101), **tapered end first**. Using a press or a block and rubber mallet, press-fit the bearing so it is flush with the surface of the center housing.

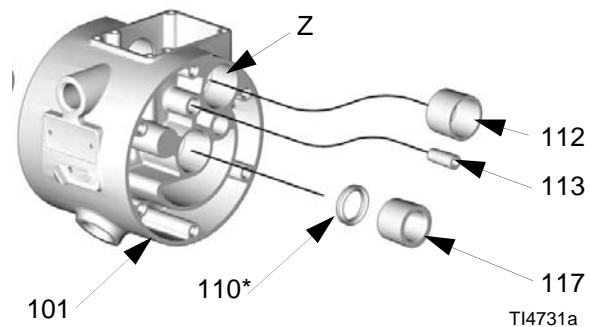

FIG. 25

3. Reassemble the air valve as explained on page 18.

- Align the new air cover gasket (119) so the pilot pin (114) protruding from the center housing (101) fits through the proper hole in the gasket.

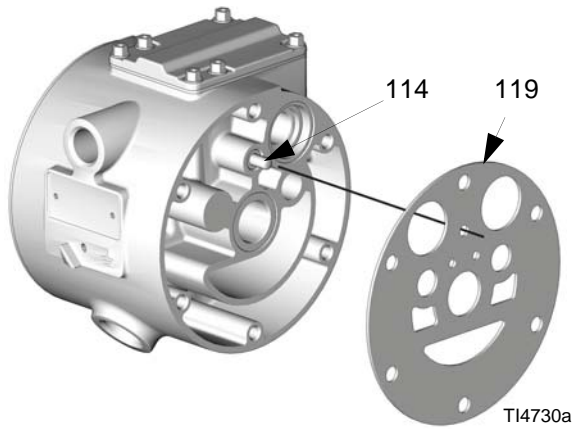

FIG. 26

- Align the air cover (120) so the pilot pin (114) fits in the middle hole (M) of the three small holes near the center of the cover.

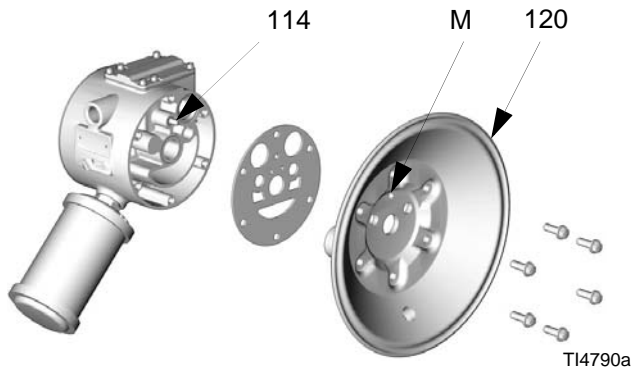

FIG. 27

- Apply medium-strength (blue) thread locker to the threads of the screws (122). Install the screws (122), handtight. Using a 10 mm socket wrench, torque the screws oppositely and evenly to 15-17 N•m (130-150 in-lb). Install the diaphragm assemblies and fluid covers as explained on page 23.

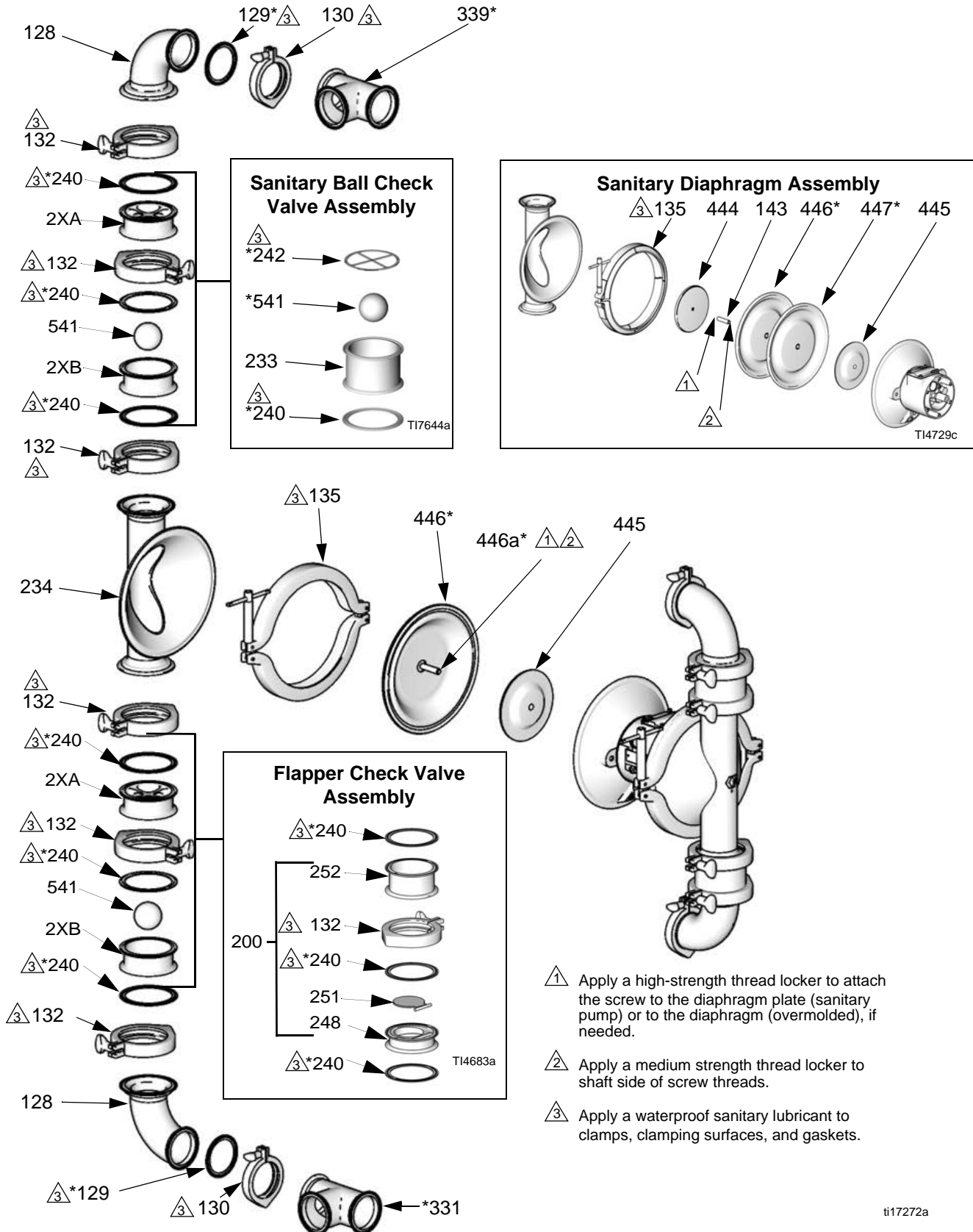

FIG. 28

- Reassemble the ball check valves and manifolds as explained on page 21.

Parts Drawing, Fluid Section

3A Pump Shown



ti17272a

Parts List, Fluid Section

Pump Configuration

Digit	Ref. No.	Part No.	Description	Qty
Model VA-H50				
3A	3A Approved Ball Check Pump			
	132	819.0504	CLAMP, 4 in.	4
	2XB	819.0526	SEAT	4
	234	819.0477	COVER, fluid	2
	240*	819.0529	GASKET, 4 in., EPDM; Qty. 2	6
	2XA	819.0527	STOP, ball	4
SB	Standard Ball Check Pump			
	132	819.0663	CLAMP, 4 in.	4
	233	819.0513	SEAT	4
	234	819.0477	COVER, fluid	2
	240*	819.0529	GASKET, 4 in., EPDM; Qty. 2	4
	242*	819.0515	GASKET, ball stop; Qty. 4	1
SF	Flapper Check Pump			
	234	819.0477	COVER, fluid	2
	240*	819.0529	GASKET, 4 in., EPDM; Qty. 2	6
	200	819.0581	MODULE, flapper; includes 4x of items 132, 248, 251, 252, and 12x item 240	1
	132	819.0504	CLAMP, 4 in.	4
	248	819.0559	HOUSING, lower flapper	4
	251	819.0560	VALVE, flapper, weldment	4
	252	819.0514	HOUSING, upper flapper	4
Model VA-H40				
All	132	819.0516	CLAMP, 3 in.	4
All	2XB	819.0530	SEAT	4
All	234	819.0483	COVER, Fluid	2
All	240*	819.0528	GASKET, 3 in., EPDM; Qty. 2	6
All	2XA	819.0531	STOP, Ball	4
	3A Approved Ball Check Pump			
3A	135	819.0565	CLAMP, sanitary, diaphragm	2
	Standard Ball Check Pump			
SB	135	819.0525	CLAMP, sanitary, diaphragm	2

* Indicates replacement parts.

Inlet and Outlet

Digit	Ref. No.	Part No.	Description	Qty
Model VA-H50				
T5	Tee, 3 in. x 2 in. tri-clamp			
	331*	819.0480	TEE, inlet	1
	339*	819.0480	TEE, outlet	1
T8	Tee, 3 in. x 3 in. tri-clamp			
	331*	819.0479	TEE, inlet	1
	339*	819.0479	TEE, outlet	1
D5	Tee, 3 in. tri-clamp x 50 mm DIN 11851			
	331*	819.0624	TEE, inlet	1
	339*	819.0624	TEE, outlet	1
D8	Tee, 3 in. tri-clamp x 80 mm DIN 11851			
	331*	819.0625	TEE, inlet	1
	339*	819.0625	TEE, outlet	1
Model VA-H40				
	Tee, 2 in. x 2 in. tri-clamp			
T5	331*	819.0484	TEE, Inlet	1
	339*	819.0484	TEE, Outlet	1
	Tee, 2 in. tri-clamp x 50 mm DIN 11851			
D5	331*	819.0623	TEE, Inlet	1
	339*	819.0623	TEE, Outlet	1

* Indicates replacement parts.

Digit	Ref.	Part	Description	Qty.
Model VA-H50				
	128	819.0478	ELBOW	4
	129	819.0528	GASKET, sanitary, EPDM, 3 in., Qty. 2	2
All	130	819.0516	CLAMP, sanitary, 3 in.	4
	132	819.0504	CLAMP, sanitary, 4 in.	8
	135	819.0518	CLAMP, sanitary, diaphragm	2
Model VA-H40				
	128	819.0485	ELBOW	4
All	129	819.0533	GASKET, sanitary, EPDM, 2 in., Qty. 2	2
	130	819.0503	CLAMP, sanitary, 2 in.	4
	132	819.0516	CLAMP, sanitary, 3 in.	8

Diaphragm Material

Digit	Ref.	Part	Description	Qty
Model VA-H40				
EO	819.0573 3A Approved, EPDM, Overmolded; includes 110 and 446			
	110	819.0429	U-CUP; Qty. 2	2
	446*†	---	DIAPHRAGM ASSEMBLY	2
	445	819.0555	PLATE, Diaphragm (air side)	2
TO	819.0571 (HD) PTFE; includes 110, 446			
	110	819.0429	U-CUP, Qty. 2	2
	446*†	---	DIAPHRAGM ASSY	2
	445	819.0535	PLATE, diaphragm (air side)	2
Model VA-H50				
EO	819.0568 3A Approved, EPDM, Overmolded; includes 110 and 446			
	110	819.0429	U-CUP; Qty. 2	2
	446*†	---	DIAPHRAGM ASSY	2
	445	819.0465	PLATE, diaphragm (air side)	2
TO	819.0572 (HD) PTFE; includes 110, 446			
	110	819.0429	U-CUP; Qty. 2	2
	446*†	---	DIAPHRAGM ASSY	2
	445	819.0536	PLATE, diaphragm (air side)	2
SP	819.0569 Santoprene; includes 110, 446			
	110	819.0429	U-CUP; Qty. 2	2
	446*†	---	DIAPHRAGM	2
	143	819.0512	BOLT	2
	444	819.0511	PLATE, diaphragm	2
	445	819.0465	PLATE, diaphragm	2

All diaphragm modules above include 2 u-cups (110) to replace seals around shaft (121).

* Indicates replacement parts. Order part number 819.0184 for lithium-based grease.

† Indicates a recommended spare part.

Check Ball Material

Digit	Ref.	Part	Description	Qty
Model VA-H40				
TF	3A Approved, PTFE, 1.5 in.			
	541*†	819.0432	BALL; Qty. 4	1
SP	Santoprene, 1.5 in.			
	541*†	819.0433	BALL, Qty. 4	1
Model VA-H50				
TF	3A Approved, PTFE, 2.25 in.			
	541*†	819.0430	BALL; Qty. 4	1
FL	Flapper check			
	NONE			
SP	Santoprene, 2.25 in.			
	541*†	819.0431	BALL; Qty. 4	1
BN	BUNA-N, 2.25 in.			
	541*†	819.0507	BALL; Qty. 4	1
VT	Fluoroelastomer, 2.25 in.			
	541*†	819.0506	BALL; Qty. 4	1
NW	Weighted Neoprene, 2.25 in.			
	541*†	819.0670	BALL; Qty. 4	1

* Indicates replacement parts. Order part number 819.0184 for lithium-based grease.

† Indicates a recommended spare part.

Parts Drawing, Air Section and Stand

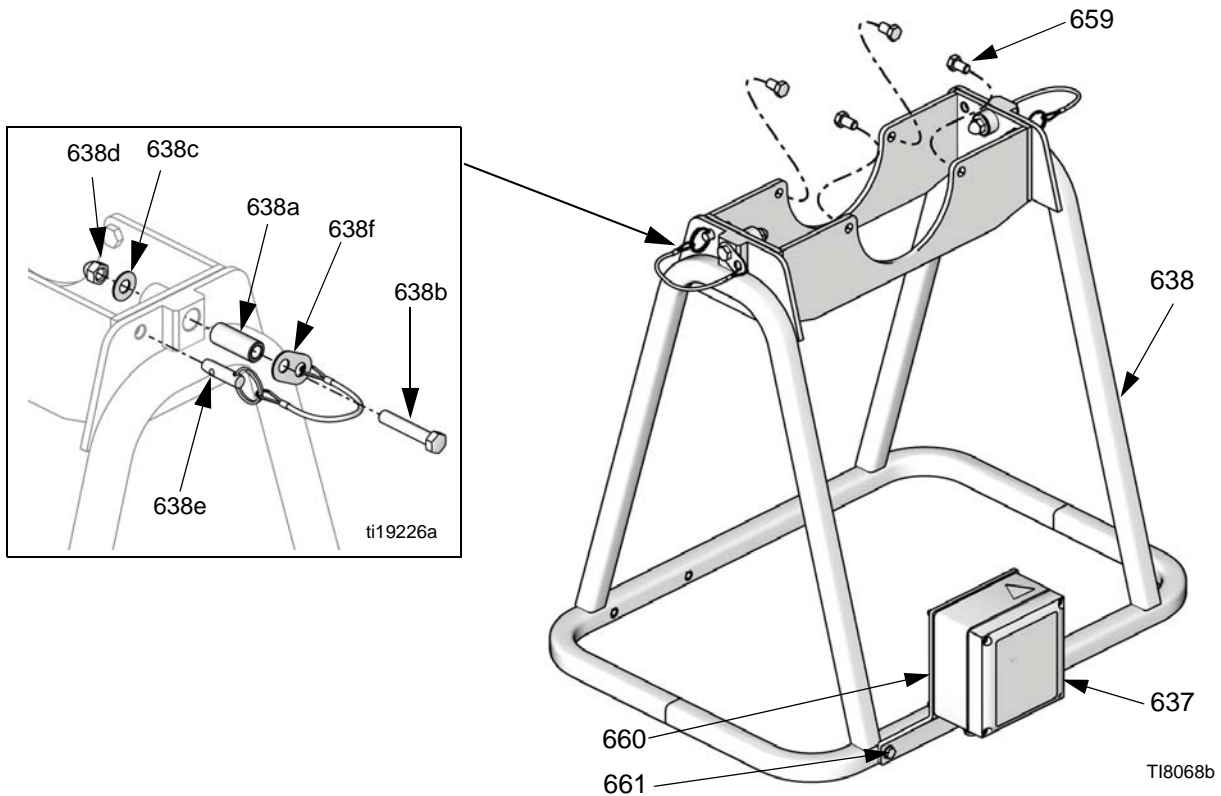
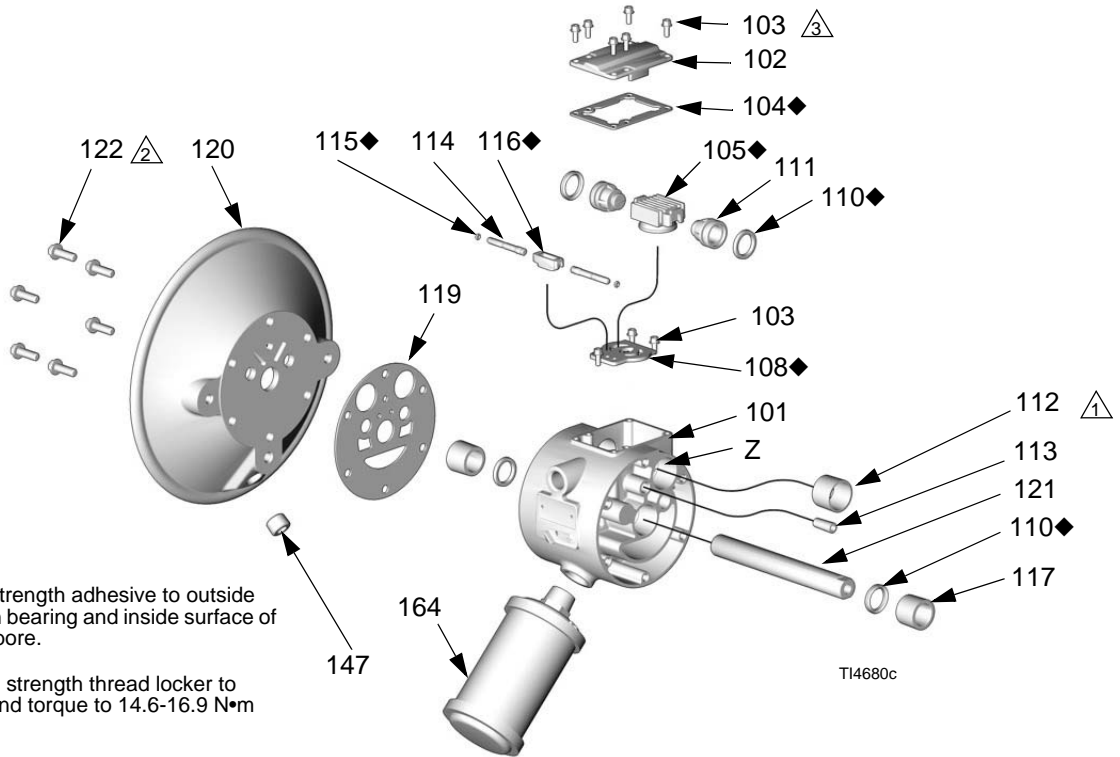

Parts List, Air Section and Stand

Air Section - All Models

Digit	Ref.	Part	Description	Qty.
ALL Models	101	819.0552	HOUSING, center	1
	102	819.0557	HOUSING, cover	1
	103	819.0439	SCREW, mach, torx; Qty. 9	1
	104◆	819.0457	GASKET, cover	1
	105◆	819.0482	CARRIAGE, manifold assy	1
	108◆	819.0524	VALVE, plate	1
	110◆	819.0429	U-CUP, packing; Qty. 2	2
	111	819.0451	PISTON, actuator; Qty. 2	1
	112	819.0452	BEARING, piston; Qty. 2	1
	113	819.0450	BEARING, pin; Qty. 2	1
	114	819.0449	PIN, push; Qty. 2	1
	115◆	819.0441	O-RING, Qty. 2	1
	116◆	819.0453	BLOCK, pilot	1
	117	819.0448	BEARING, shaft; Qty. 2	1
	119	819.0444	GASKET air cover; Qty. 2	1
	120	819.0510	COVER, machined air, VA-H50	2
		819.0521	COVER, machined air, VA-H40	2
	121	819.0463	SHAFT	1
	122	819.0428	SCREW; Qty. 10	1
	147	819.0419	PLUG; Qty. 2	1
162▲	819.4313	TAG, warning	1	
164	819.0519	MUFFLER	1	

◆ Parts included in Air Valve Repair Kit 819.0664 (purchase separately). Order part number 819.0184 for lithium-based grease.

▲ Replacement Danger and Warning labels, tags, and cards are available at no cost.

Leak Detector and Pump Stand

Digit	Ref.	Part	Description	Qty
3A	3A Approved, Leak Detector and Pump Stand VA-H40 and VA-H50			
	637	819.0517	LEAK DETECTOR	1
	638	819.0582	FRAME (includes 4 bolts, ref. 659)	1
	659	819.0509	BOLT, sst; Qty. 4	1
	660	819.0548	GASKET, upper; Qty. 2	1
	661	819.0549	GASKET, lower; Qty. 2	1
SB	Pump Stand Only - VA-H40 and VA-H50			
	638	819.0582	FRAME (includes 4 bolts, ref. 659)	1
	659	819.0509	BOLT, sst; Qty. 4	1

* Indicates replacement parts.

† Indicates a recommended spare part.

Kit 819.0583 Hinge Repair Kit

Ref.	Description	Qty.
638a	BUSHING	2
638b	BOLT	2
638c	WASHER	2
638d	NUT, acorn	2

Kit 819.0584 Quick-Release Pin Repair Kit

Ref.	Description	Qty.
638e	LOCK PIN, with lanyard	2
638f	RETAINER	2

Accessories

819.0517 Leak Detector

Sensor and control package that monitors the diaphragm condition. In case of diaphragm failure, the control will provide an audible alarm and relay contacts for remote alarms or solenoids. See Leak Detector manual 819.0661.

NOTE: To be  approved, a leak detection system must be used on the pump. Any pump with a leak detector installed is NOT Atex approved.

NOTE: To replace a sensor, order Part No. 819.0665 Leak Detector Sensor Replacement Kit. The kit includes one sensor.

VA-H50 Conversion Kits

819.0580 3A Approved Ball Check Conversion Kit

Converts flapper check valve to 3A ball check valve. Includes four seats and four ball stops. Balls need to be ordered separately.

Part No.	Description	Qty.
819.0526	SEAT, ball	4
819.0529	GASKET, 4 in.	12
819.0504	CLAMP, 4 in.	4
819.0527	STOP, ball	4

819.0581 Flapper Valve Conversion Kit

Converts ball check valve to flapper check valve. Includes four flapper assemblies. See **Flapper Valve Assembly**, page 30.

Part No.	Description	Qty.
819.0529	GASKET, 4 in., EPDM	12
819.0514	HOUSING, upper flapper	4
819.0559	HOUSING, lower flapper	4
819.0560	VALVE, flapper, weldment	4
819.0504	CLAMP, 4 in.	4

819.0578 Sanitary Ball Check Conversion Kit

Converts flapper check valve to sanitary ball check valve. Includes four seats and four ball stops. Balls need to be ordered separately.

Part No.	Description	Qty.
819.0513	SEAT, ball	4
819.0515	GASKET, ball stop	4

Model VA-H40 Dimensional Drawing

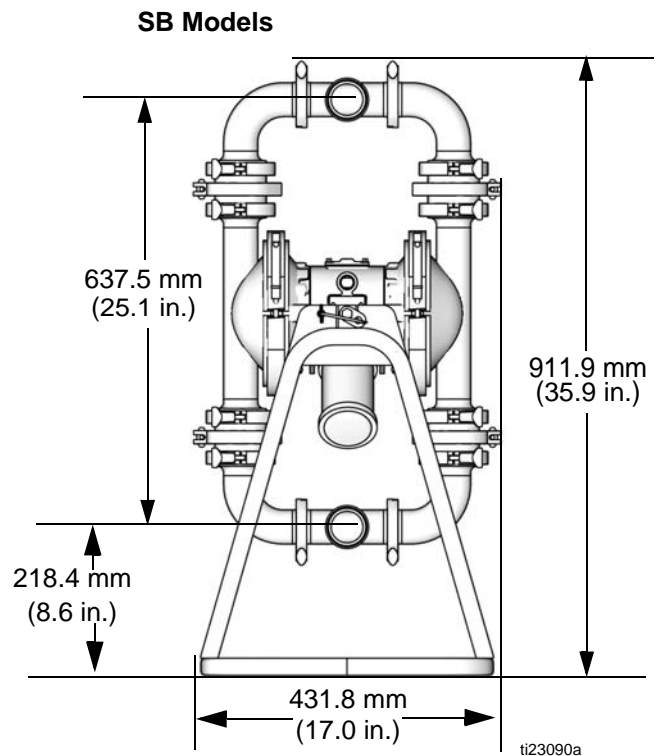
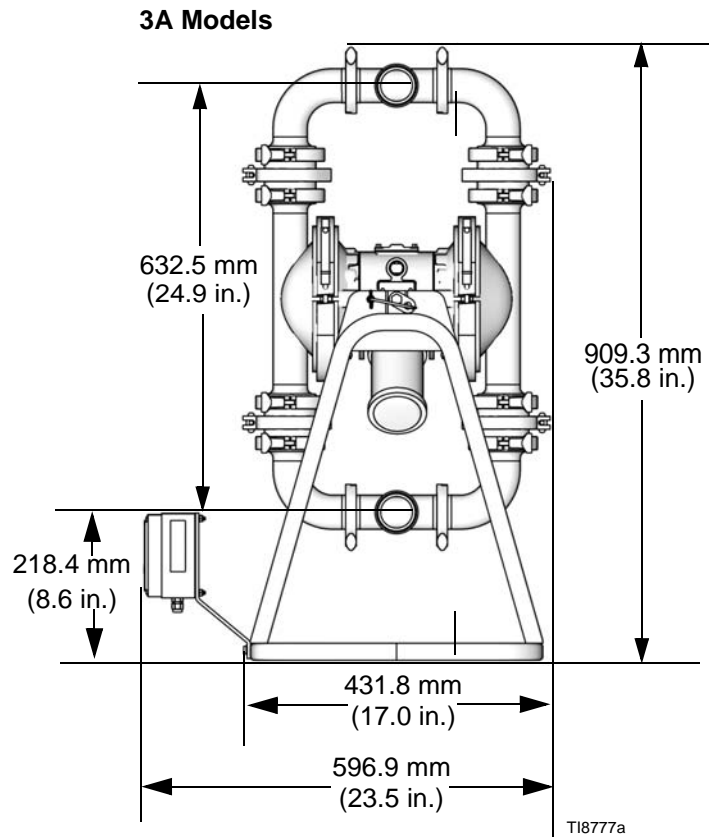
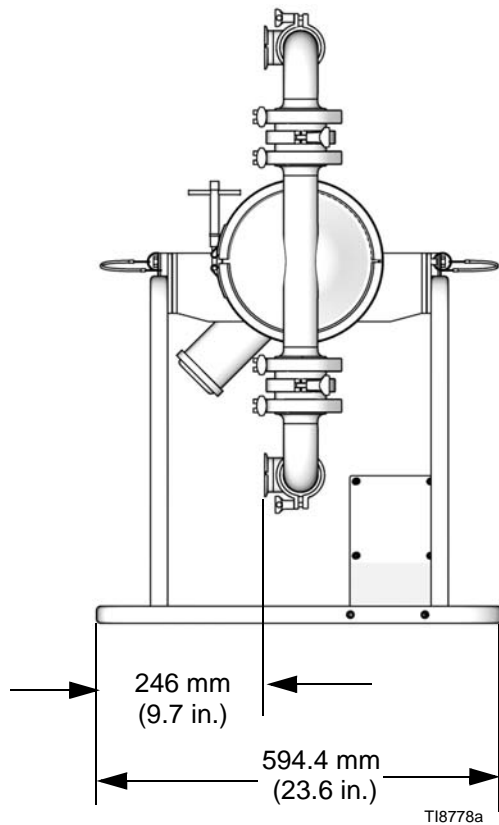

NOTE: Dimensions are identical for tri-clamp and DIN pumps.

Model VA-H40 Technical Data

	U.S.	Metric
Maximum fluid working pressure	120 psi	8 bar (0.8 MPa)
Air pressure operating range	20-120 psi	1.4-8 bar (0.14-0.8 MPa)
Maximum air consumption	125 scfm	3.6 Nm ³ /min
Operating air consumption	50 scfm at 70 psi/50 gpm	1.4 Nm ³ /min at 4.8 bar/75.7 lpm
Maximum free-flow delivery	100 gpm	378.5 l/min
Maximum pump speed	200 cpm	
* Flow per cycle	0.5 gallons	1.89 liters
Maximum suction lift (varies widely based on ball/seat selection and wear, operating speed, material properties, and other variables)	28 ft wet 15 ft dry	8.5 m wet 15.9 m dry
Maximum size pumpable solids	5/8 in.	4.8 mm
** Maximum Noise Level at full flow (120 psi, 0.8 MPa)	90 dBa	
** Sound Power Level	103 dBa	
** Operating Noise Level	85 dBa at 70 psi and 50 cpm	85dBa at 4.8 bar and 50 cpm
Maximum fluid operating temperature is based on the following maximum diaphragm, ball, and seat temperature ratings.		
PTFE balls	220°F	104.4°C
PTFE/EPDM overmolded diaphragm)	180°F	82.2°C
Santoprene balls or diaphragm	180°F	82.2°C
3A Approved EPDM overmolded diaphragm	275°F	135°C
Air inlet size	0.5 in. npt(f)	
Wetted parts ***All fluid contact materials are FDA-compliant and meet the United States Code of Federal Regulations (CFR) Title 21, Section 177.		
Wetted materials on all models	316 SST, 3A Approved EPDM, PTFE	
Wetted material depending on model	Santoprene®, 3A Approved EPDM, PTFE	
CAUTION: Santoprene® may be used only with non-fatty, non-oily foods or alcohols up to 15%.		
Non-wetted external parts	300 series stainless steel, aluminum (A380), polyester (labels), LDPE foam (gasket)	
Weight	97 lb	44 kg

Santoprene® is a registered trademark of the Monsanto Co.

* Displacement per cycle may vary based on suction condition, discharge head, air pressure, and fluid type.

** Noise levels measured with the pump mounted on the stand. Sound power measured per ISO Standard 9614-1.

*** The pump user must verify that the construction materials meet their specific application requirements.

Model VA-H40 Performance Chart

Test Conditions: Pump tested in water with inlet submerged

To find Fluid Outlet Pressure

(psi/MPa/bar) at a specific fluid flow (gpm/lpm) and operating air pressure (psi/MPa/bar):

1. Locate fluid flow rate along bottom of chart.
2. Follow vertical line up to intersection with selected fluid outlet pressure curve.
3. Follow left to scale to read fluid outlet pressure.

To find Pump Air Pressure

(scfm or Nm³/min) at a specific fluid flow (gpm/lpm) and operating air pressure (psi/MPa/bar):

1. Locate fluid flow rate along bottom of chart.
2. Read vertical line up to intersection with selected air consumption curve.
3. Follow left to scale to read fluid outlet pressure.

VA-H40 Performance Chart

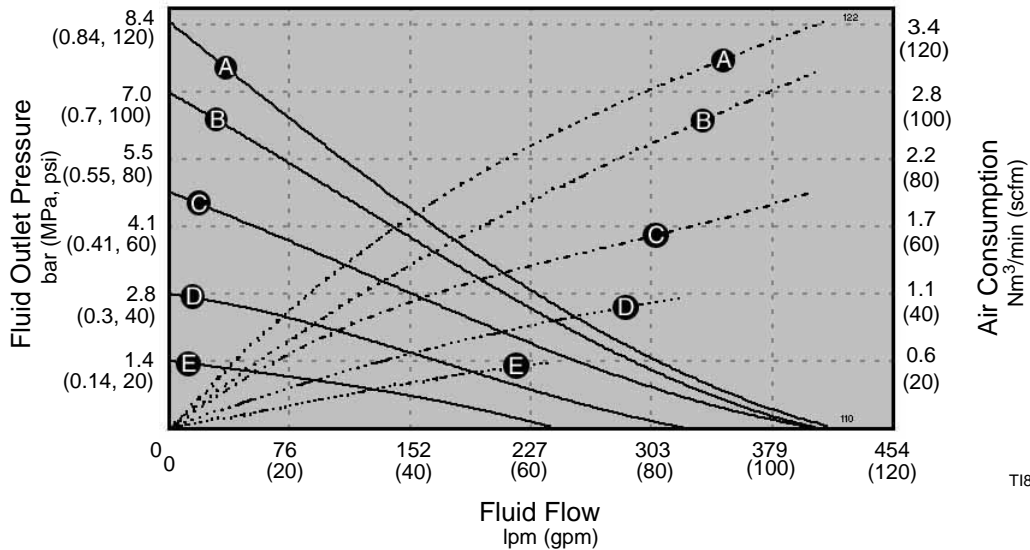

T18646

AIR PRESSURES	LEGEND
(A) = @ 120 psi (8.4 bar, 0.84 MPa)	Air Consumption - - - - -
(B) = @ 100 psi (7.0 bar, 0.7 MPa)	Fluid Flow - - - - -
(C) = @ 70 psi (4.8 bar, 0.5 MPa)	
(D) = @ 40 psi (2.8 bar, 0.3 MPa)	
(E) = @ 20 psi (1.4 bar, 0.14 MPa)	

T18647

Model VA-H50 Dimensional Drawing

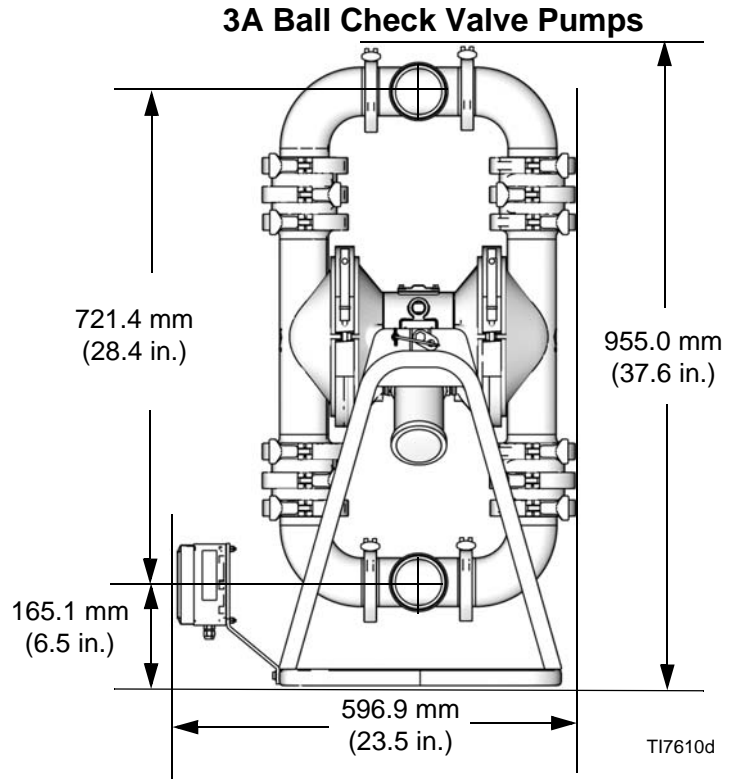
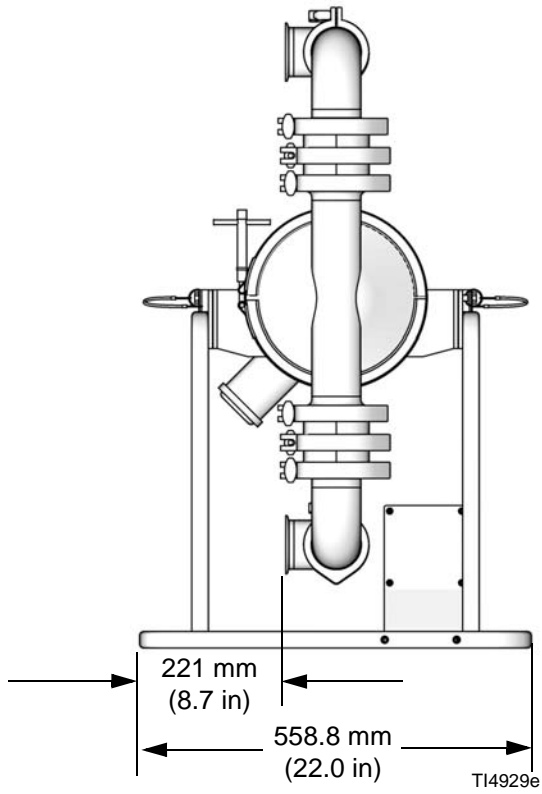

Sanitary Ball Check Valve Pumps

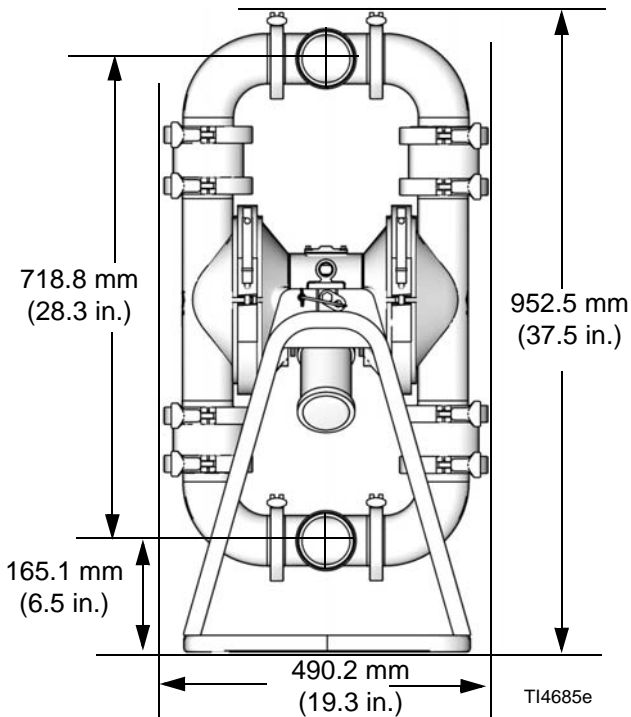

Flapper Check Valve Pumps

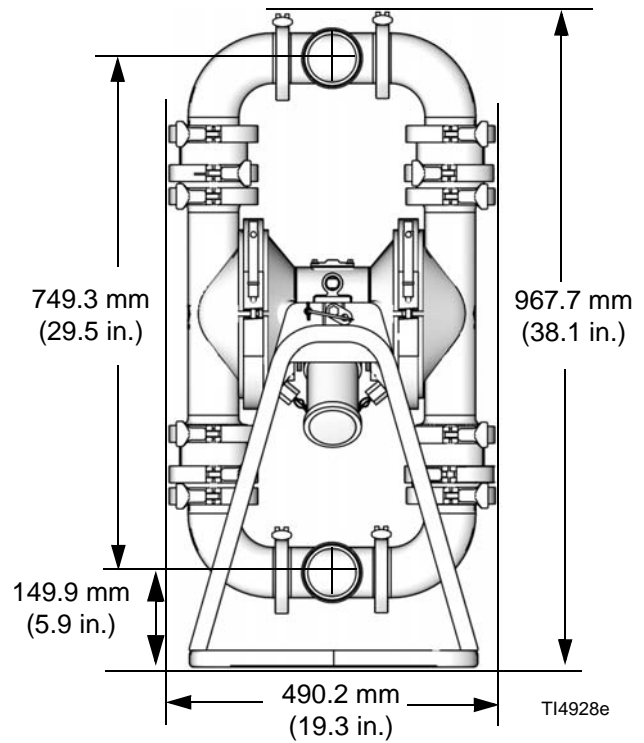

NOTE: Dimensions are identical for tri-clamp and DIN pumps.

Model VA-H50 Technical Data

	U.S.	Metric
Maximum fluid working pressure	120 psi	8 bar (0.8 MPa)
Air pressure operating range	20-120 psi	1.4-8 bar (0.14-0.8 MPa)
Maximum air consumption	175 scfm	4.9 Nm ³ /min
Operating air consumption	50 scfm at 70 psi/60 gpm	1.4 Nm ³ /min at 4.8 bar/227 lpm
Maximum free-flow delivery	150 gpm	567.8 l/min
Maximum pump speed	145 cpm	
* Flow per cycle	1.03 gallons	3.9 liters
Maximum suction lift (varies widely based on ball/seat selection and wear, operating speed, material properties, and other variables)		
Flapper Models	10 ft wet 5 ft dry	3.5 m wet 1.75 m dry
Ball-check Models	18 ft. wet 9 ft dry	5.5 m wet 2.75 m dry
Maximum size pumpable solids		
Flapper Models	2.5 in.	63.5 mm
Ball-check Models	1.0 in.	25.4 mm
** Maximum Noise Level at full flow (120 psi, 0.8 MPa)	90 dBa	
** Sound Power Level	103 dBa	
** Operating Noise Level	85 dBa at 70 psi and 50 cpm	85 dBa at 4.8 bar and 50 cpm
Maximum fluid operating temperature is based on the following maximum diaphragm, ball, and seat temperature ratings.		
PTFE balls	220°F	104.4°C
PTFE/EPDM overmolded (HD) diaphragm	180°F	82.2°C
Santoprene balls or diaphragms	180°F	82.2°C
3A Approved EPDM overmolded diaphragm	275°F	135°C
Buna-N balls or diaphragm	180°F	82.2°C
Fluoroelastomer balls or diaphragm	250°F	121.1°C
Air inlet size	0.5 in. npt(f)	
Wetted parts ***All fluid contact materials are FDA-compliant and meet the United States Code of Federal Regulations (CFR) Title 21, Section 177.		
Wetted materials on all models	316 SST, 3A Approved EPDM	
Wetted material depending on model	Santoprene®, 316 SST, Buna-N (Nitrile), fluoroelastomer, 3A Approved EPDM, PTFE	
CAUTION: Santoprene® may be used only with non-fatty, non-oily foods or alcohols up to 15%.		
Non-wetted external parts	300 series stainless steel, polyester (labels), LDPE foam (gasket)	
Weight	145 lb	66 kg

Santoprene® is a registered trademark of the Monsanto Co.

* Displacement per cycle may vary based on suction condition, discharge head, air pressure, and fluid type.

** Noise levels measured with the pump mounted on the stand. Sound power measured per ISO Standard 9614-1.

*** The pump user must verify that the construction materials meet their specific application requirements.

Model VA-H50 Performance Chart

Test Conditions: Pump tested in water with inlet submerged

To find Fluid Outlet Pressure

(psi/MPa/bar) at a specific fluid flow (gpm/lpm) and operating air pressure (psi/MPa/bar):

1. Locate fluid flow rate along bottom of chart.
2. Follow vertical line up to intersection with selected fluid outlet pressure curve.
3. Follow left to scale to read fluid outlet pressure.

To find Pump Air Pressure

(scfm or Nm³/min) at a specific fluid flow (gpm/lpm) and operating air pressure (psi/MPa/bar):

1. Locate fluid flow rate along bottom of chart.
2. Read vertical line up to intersection with selected air consumption curve.
3. Follow left to scale to read fluid outlet pressure.

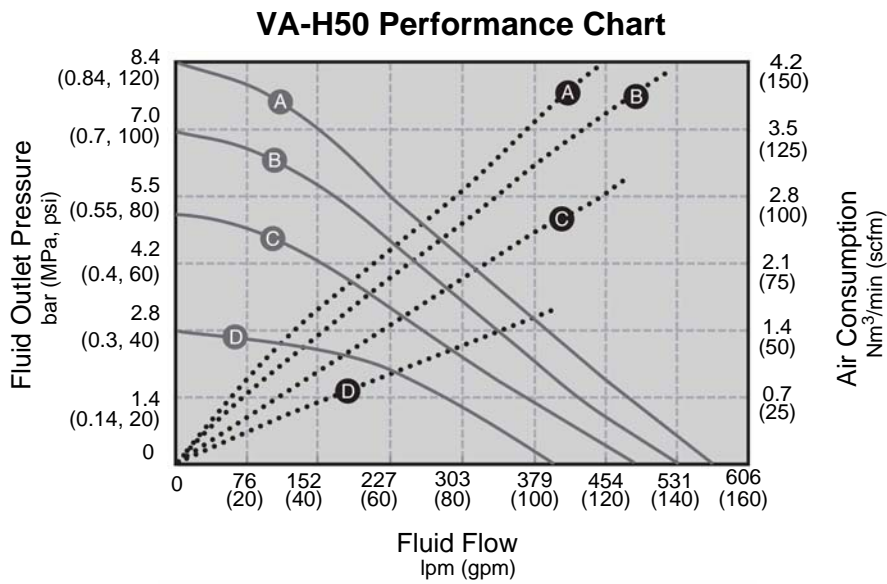

T18644a

AIR PRESSURES	LEGEND
(A) = @ 120 psi (8.4 bar, 0.84 MPa)	Air Consumption (dotted line)
(B) = @ 100 psi (7.0 bar, 0.7 MPa)	Fluid Flow _____ (solid line)
(C) = @ 70 psi (4.8 bar, 0.5 MPa)	
(D) = @ 40 psi (2.8 bar, 0.3 MPa)	

T18645a



EU-DECLARATION OF CONFORMITY

EU-CONFORMITEITSVERKLARING, DÉCLARATION UE DE CONFORMITÉ, EU-KONFORMITÄTSEKTLÄRUNG DICHIARAZIONE DI CONFORMITÀ UE, EU-OVERENSSTEMMELSESEKTLÆRING, ΔΗΛΩΣΗ ΣΥΜΜΟΡΦΩΣΗΣ ΕΕ, DECLARAÇÃO UE DE CONFORMIDADE, DECLARACIÓN UE DE CONFORMIDAD, EU-VAATIMUSTENMUKAISUUSVAKUUTUS, EU-FÖRSÄKRAN OM ÖVERENSSTÄMMELSE, EU PROHLÁŠENÍ O SHODĚ, ELI VASTAVUSDEKLARATSIOON, EU-MEGFELELŐSÉGI NYILATKOZAT, ES ATBILSTĪBAS DEKLARĀCIJA, ES ATITIKTIKTES DEKLARACIJA DEKLARACJA ZGODNOŚCI UE, DIKJARAZZJONI TA' KONFORMITÀ TAL-UE, EU IZJAVA O SUKLADNOSTI, EU VYHLÁSENIE O ZHODE, ЕС ДЕКЛАРАЦИЯ ЗА СЪОТВЕТСТВИЕ, DECLARAȚIA UE DE CONFORMITATE

Model

Modèle, Modell, Modello, Μοντέλο, Modelo, Malli, Mudel, Modelis, Mudell, Модел, Samhail

**Verder HI-CLEAN VA-H40 and VA-H50
Sanitary AODD Pumps**

Part

Bestelnr., Type, Teil, Codice, Del, Μέρος, Peça, Referencia, Osa, Součást, Részegység, Dajka, Dalis, Część, Taqsim, Čast, Част, Páirt, Parte

**All pumps with Part Numbers
810.0830 – 810.0849, 810.0889**

Complies With The EC Directives:

Voldoet aan de EG-richtlijnen, Conforme aux directives CE, Entspricht den EG-Richtlinien, Conforme alle direttive CE, Overholder EF-direktiverne, Σύμφωνα με τις Οδηγίες της ΕΚ, Em conformidade com as Directivas CE, Cumple las directivas de la CE, Täytää EY-direktiivien vaatimukset, Uppfyller EG-direktiven, Shoda se směrnicemi ES, Vastab EU direktiividele, Kielegíti az EK irányelvek követelményeit, Atbilst EK direktívam, Atitinka šias ES direktyvas, Zgodność z Dyrektywami UE, Konformi mad-Direttivi tal-KE, V skladu z direktivami ES, Je v súlade so smernicami ES, Съвместимост с Директиви на ЕО, Tá ag teacht le Treoracha an CE, Respectá directivele CE

2006/42/EC Machinery Directive

2014/34/EC ATEX Directive (Ex II 2 G c IIB T6; Does not apply to 810.0830, 810.0831, 810.0834, 810.0835, 810.0838, 810.0839) – Tech File stored with NB 0359

Standards Used:

Gebruikte maatstaven, Normes respectées, Verwendete Normen, Norme applicate, Anvendte standarder, Πρότυπα που χρησιμοποιήθηκαν, Normas utilizadas, Normas aplicadas, Sovellettavat standardit, Tillämpade standarder, Použité normy, Rakendatud standardid, Alkalmazott szabványok, Izmantotie standarti, Taikyti standartai, Užyte normy, Standards Užati, Uporabljeni standardi, Použité normy, Използвани стандарти, Cailghdeáin arna n-úsáid, Standarde utilizate

ISO 12100 EN 1672-2

ISO 14159 EN 13463-5

ISO 9614-1 EN 1127-1

Notified Body for Directive

Aangemelde instantie voor richtlijn, Organisme notifié pour la directive, Benannte Stelle für diese Richtlinie, Ente certificatore della direttiva, Bemyndiget organ for direktiv, Διακωλυμένο όργανο Οδηγίας, Organismo notificado relativamente à directiva, Organismo notificado de la directiva, Direktiivin mukaisesti ilmoitettu tarkastuslaitos, Anmält organ för direktivet, Úředně oznámený orgán pro směrnici, Teavitatud asutus (direktiivi järgi), Az irányelvvvel kapcsolatban értesített testület, Pilnvarotā iestāde saskaņā ar direktīvu, Apie direktīvu Informuota institūcija, Ciało powiadomione dla Dyrektywy, Korp avzat bid-Direttiva, Priglašeni organ za direktivo, Notifikovaný orgán pre smernicu, Нотифициран орган за Директива, Comhlacht ar tugadh fógra dó, Organism notificat in conformitate cu directiva

--	--	--

Approved By:

Goedgekeurd door, Approuvé par, Genehmigt von, Approvato da, Godkendt af, Έγκριση από, Aprobado por, Aprobado por, Hyväksynyt, Intygas av, Schwäilit, Kinnitanud, Jóvahagyta, Apstiprināts, Patvirtino, Zatwierdzone przez, Approvat minn, Odobril, Schválené, Одобрено от, Faofa ag, Aprobat de

**Werner Bosman
Managing Director**

21 February 2017

VERDER BV
Leningradweg 5
9723 TP Groningen
NETHERLANDS

819.0655

B

This declaration of conformity is issued under the sole responsibility of the manufacturer. Deze conformiteitsverklaring wordt verstrekt onder volledige verantwoordelijkheid van de fabrikant. La présente déclaration de conformité est établie sous la seule responsabilité du fabricant. Die alleinige Verantwortung für die Ausstellungsverklärung trägt der Hersteller. La presente dichiarazione di conformità è rilasciata sotto la responsabilità esclusiva del fabbricante. Denne overensstemmelseserklæring udstedes på fabrikantens ansvar. Η παρούσα δήλωση συμμόρφωσης εκδίδεται με αποκλειστική ευθύνη του κατασκευαστή. A presente declaração de conformidade é emitida sob a exclusiva responsabilidade do fabricante. Tämä vaatimustenmukaisuusvakuutus on annettu valmistajan yksinomaista vastuulla. Denna försäkrän om överensstämmelse utfärdas på tillverkarens eget ansvar. Toto prohlášení o shodě se vydává na výhradní odpovědnost výrobce. Käesolev vastavusdeklaratsioon on välja antud tootja ainuvastutusel. Ezt a megfelelőségi nyilatkozatot a gyártó kizárólagos felelőssége mellett adják ki. Ši atbilstības deklarācija ir izdota vienīgi uz ražotāja atbildību. Ši atitiktības deklaracija išduota tik gamintojo atsakomybe. Niniejsza deklaracja zgodności wydana zostaje na wyłączną odpowiedzialność producenta. Din idikjarazzjoni tal-konformità qiegħda tinħareġ taħt ir-responsabbiltà unika tal-manifattur. Ta izjava o skladnosti je izdana na lastno odgovornost proizvajalca. Toto vyhlásenie o zhode sa vydáva na výhradnú zodpovednosť výrobcu. Настоящая декларация за съответствие е издадена на отговорността на производителя: Prezenta declarație de conformitate este emisă pe răspunderea exclusivă a producătorului.



DECLARATION OF COMPLIANCE

Statement of compliance with European Union regulation
(EC) no 1935/2004 on materials and articles intended to come into
contact with food
Requirement per Article 16 of EC 1935/2004



Verder BV declares that the equipment listed below contains materials that have been demonstrated to meet the requirements of Regulations: **EC 1935/2004** of 27 October 2004 and **EC 2023/2006** of 22 December 2006

Model VA-H40 and VA-H50 HI-CLEAN AODD Pumps

Part No 810.0830, 810.0831, 810.0832, 810.0833, 810.0834, 810.0835, 810.0836, 810.0837, 810.0838, 810.0839, 810.0842, 810.0843, 810.0844, 810.0845, 810.0848, 810.0849, 810.0889

Materials used in this equipment that are intended to contact food belong to the groups of materials listed in Annex 1 (EC) 1935/2004 (List of groups of materials and articles which may be covered by specific measures)

- | | |
|---|--|
| <input type="checkbox"/> Adhesives (2) | <input checked="" type="checkbox"/> Plastics (10) |
| <input type="checkbox"/> Ceramics (3) | <input type="checkbox"/> Printing Inks (11) |
| <input checked="" type="checkbox"/> Rubbers (5) | <input type="checkbox"/> Silicones (13) |
| <input checked="" type="checkbox"/> Metals and Alloys (8) | <input type="checkbox"/> Varnishes and Coatings (15) |

Materials used in this equipment that are intended to contact food were assessed using one or more of the regulations and/or texts referenced in ANNEX 1 of this declaration. Compliance is subject to material and equipment storage, handling and usage recommended by the equipment instruction manual, and supplemental technical publications published by Verder.

The establishment of this declaration is based on the following:

- Statements of raw material suppliers
- Analysis of global migration
- Analysis of materials is subject to limitations (Listed in ANNEX 2)
- Other (Listed in ANNEX 3)

Verder BV will make available to the competent authorities appropriate documentation to demonstrate this compliance.

APPROVED BY:

Werner Bosman – Managing Director

VERDER BV
Leningradweg 5
9723 TP Groningen
NETHERLANDS

Date: **21 February 2017**

Part Number:
819.0658

ANNEX 1 TO DECLARATION OF COMPLIANCE References and Regulations Used

All Materials:

Framework Regulation (EC) No 1935/2004 of the European Parliament and of the Council of 27 October 2004 on materials and articles intended to come into contact with food and repealing Directives 80/590/EEC and 89/109 EEC

Commission Regulation (EC) No 2023/2006 of 22 December 2006 on good manufacturing practices for materials and articles intended to come into contact with food

Metals and Alloys:

Technical Document – Guidelines on Metals and Alloys Used as Food Contact Materials (09.03.2001)

Plastics:

Commission Regulation (EU) No 10/2011 on plastic materials and articles intended to come into contact with food

Commission Regulation (EU) No 1282/2011 amending and correcting Commission Regulation (EU) No 10/2011 on plastic materials and articles intended to come into contact with food

Rubber and Elastomers:

Council of Europe Committee of Ministers Resolution ResAP(2004)4 on rubber products intended to come into contact with foodstuffs

US Food and Drug Administration 21 CFR Ch.1 Title 177.26 Rubber articles Intended for repeated Use.

ANNEX 2 TO DECLARATION OF COMPLIANCE Analysis of Materials Subject to Limitations

The following wetted parts have special conditions and are therefore subject to the following limitations.

Part No	Description	Limitation
819.0568	EPDM Diaphragm	Migration testing only done at these conditions: 5 minutes, 40°C, fatty simulants. Results at other conditions are unknown.
819.0571 and 819.0572	PTFE Overmolded Diaphragm	Contact is not to exceed 24 hours when temperatures are above 85°C.

All wetted parts and/or materials used in this product have not been tested under all conditions using all simulants. It is the responsibility of the end user to assure compliance under the specific conditions used by the end user.

ANNEX 3 TO DECLARATION OF COMPLIANCE Other Items Used to Establish this Declaration

None

Date: **21 February 2017**

Part Number:
819.0658

Model VA-H50 Performance Chart

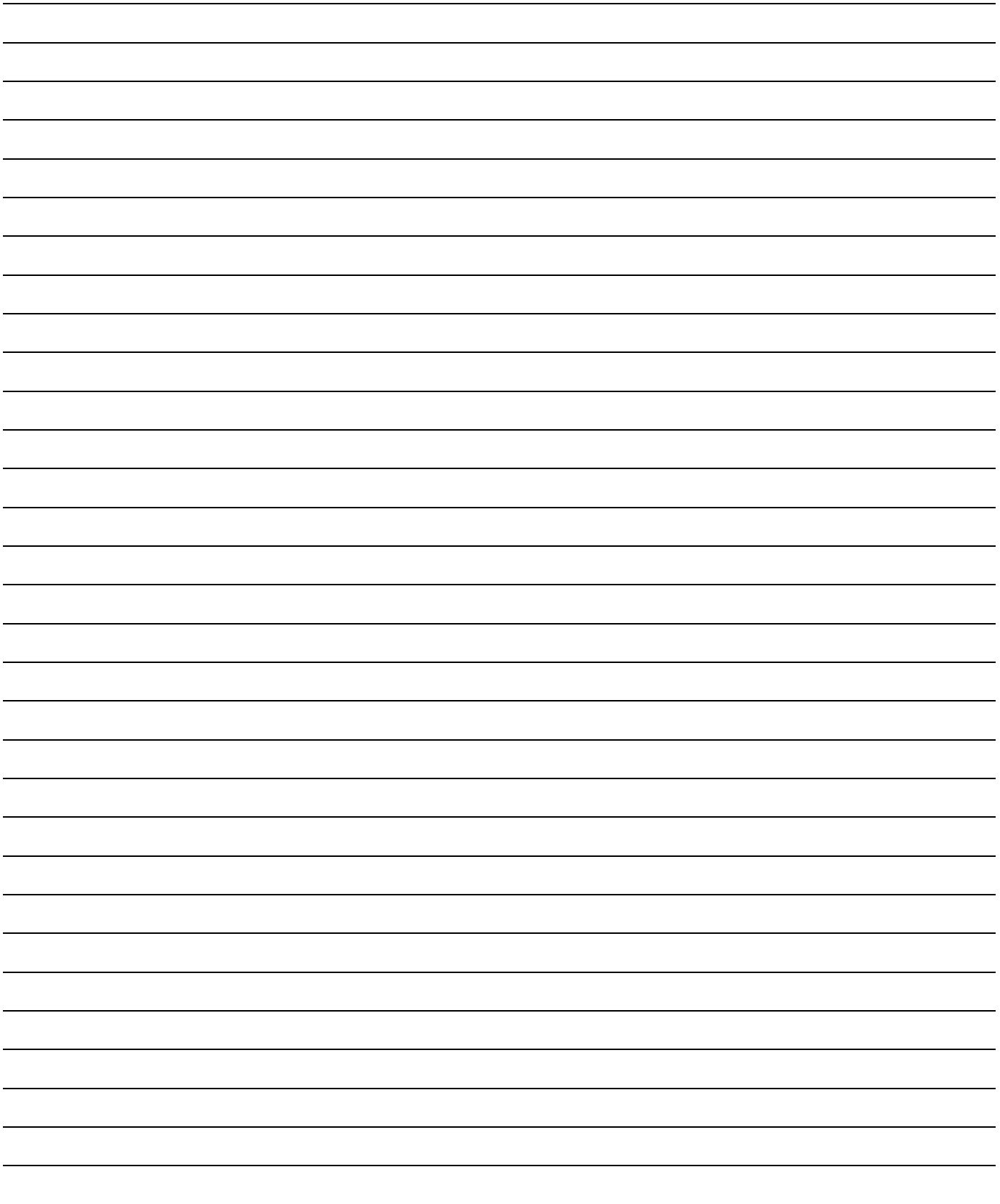

Customer Services/Guarantee

CUSTOMER SERVICES

If you require spare parts, please contact your local distributor, providing the following details:

- Pump Model
- Type
- Serial Number, and
- Date of First Order.

GUARANTEE

All VERDER pumps are warranted to the original user against defects in workmanship or materials under normal use (rental use excluded) for two years after purchase date. This warranty does not cover failure of parts or components due to normal wear, damage or failure which in the judgement of VERDER arises from misuse.

Parts determined by VERDER to be defective in material or workmanship will be repaired or replaced.

LIMITATION OF LIABILITY

To the extent allowable under applicable law, VERDER's liability for consequential damages is expressly disclaimed. VERDER's liability in all events is limited and shall not exceed the purchase price.

WARRANTY DISCLAIMER

VERDER has made an effort to illustrate and describe the products in the enclosed brochure accurately; however, such illustrations and descriptions are for the sole purpose of identification and do not express or imply a warranty that the products are merchantable, or fit for a particular purpose, or that the products will necessarily conform to the illustration or descriptions.

PRODUCT SUITABILITY

Many regions, states and localities have codes and regulations governing the sale, construction, installation and/or use of products for certain purposes, which may vary from those in neighboring areas. While VERDER attempts to assure that its products comply with such codes, it cannot guarantee compliance, and cannot be responsible for how the product is installed or used. Before purchasing and using a product, please review the product application as well as the national and local codes and regulations, and be sure that product, installation, and use complies with them.

Original instructions. This manual contains English.
Revision J, April 2017

Austria

Verder Austria
Eitnergasse 21/Top 8
A-1230 Wien
AUSTRIA
Tel: +43 1 86 51 074 0
Fax: +43 1 86 51 076
e-mail: office@verder.at

Belgium

Verder nv
Kontichsesteenweg 17
B-2630 Aartselaar
BELGIUM
Tel: +32 3 877 11 12
Fax: +32 3 877 05 75
e-mail: info@verder.be

China

Verder Shanghai Instruments and Equipment Co., Ltd
Building 8 Fuhai Business Park No. 299
Bisheng Road, Zhangjiang Hiteck Park
Shanghai 201204
CHINA
Tel: +86 21 33932950
Fax: +86 21 33932955
e-mail: info@verder.cn

Bulgaria

Verder Bulgaria Ltd
Vitosh department,
Manastriski Livadi Zapad
district,
110 Bulgaria Blvd., 2-nd
Floor, apt. 15-16,
1618 - Sofia
BULGARIA
Tel: 0878407370
Fax: 02 9584085
email: office@verder.bg

Czech Republic

Verder s.r.o.
Vodnanská 651/6 (vchod
Chlumecka 15)
198 00 Praha 9-Kyje
CZECH REPUBLIC
Tel: +420 261 225 386-7
Web: <http://www.verder.cz>
e-mail: info@verder.cz

Denmark

Sales Denmark
Leningradweg 5
NL 9723 TP Groningen
THE NETHERLANDS
Tel: +45 3636 4600
e-mail: info@verder.dk

France

Verder France
Parc des Bellevues,
Rue du Gros Chêne
F-95610 Eragny sur Oise
FRANCE
Tel: +33 134 64 31 11
Fax: +33 134 64 44 50
e-mail: verder-
info@verder.fr

Germany

Verder Deutschland GmbH
Retsch-Allee 1-5
42781 Haan
GERMANY
Tel: 02104/2333-200
Fax: 02104/2333-299
e-mail: info@verder.de

Hungary

Verder Hungary Kft
Budafoke ut 187 - 189
HU-1117 Budapest
HUNGARY
Tel: 0036 1 3651140
Fax: 0036 1 3725232
e-mail: info@verder.hu

India

Verder India Pumps Pvt
Ltd.
Plot No-3B, D-1 Block,
MIDC Chinchwad,
Pune - 411019
INDIA
Tel: +91 20 27468485
e-mail:
Sales@verder.co.in

Italy

Verder Italia
Via Maestri del Lavoro, 5
5 Vazia, Rieti
ITALY
Tel: +39 0746 221224
e-mail: info@verder.it

The Netherlands

Verder BV
Leningradweg 5
NL 9723 TP Groningen
THE NETHERLANDS
Tel: +31 50 549 59 00
Fax: +31 50 549 59 01
e-mail: info@verder.nl

Poland

Verder Polska
ul.Ligonia 8/1
PL-40 036 Katowice
POLAND
Tel: +48 32 78 15 032
Fax: +48 32 78 15 034
e-mail: verder@verder.pl

Romania

Verder România
Drumul Balta Doamnei
no 57-61
Sector 3
CP 72-117
032624 Bucuresti
ROMANIA
Tel: +40 21 335 45 92
Fax: +40 21 337 33 92
e-mail: office@verder.ro

Slovak Republik

Verder Slovakia s.r.o.
Silacska 1
SK-831 02 Bratislava
SLOVAK REPUBLIK
Tel: +421 2 4463 07 88
Fax: +421 2 4445 65 78
e-mail: info@verder.sk

South Africa

Verder SA
197 Flaming Rock Avenue
Northlands Business Park
Newmarket Street
ZA Northriding
SOUTH AFRICA
Tel: +27 11 704 7500
Fax: +27 11 704 7515
e-mail: info@verder.co.za

Switzerland

Verder Deutschland GmbH
Sales Switzerland
Retsch-Allee 1-5
D-42781 Haan
GERMANY
Tel: +41 (0)61 331 33 13
Fax: +41 (0)61 331 63 22
e-mail: info@verder.ch

United Kingdom

Verder UK Ltd.
Unit 3 California Drive
Castleford, WF10 5QH
UNITED KINGDOM
Tel: +44 (0) 1924 221 001
Fax: +44 (0) 1132 465 649
e-mail: info@verder.co.uk

United States of America

Verder Inc.
312 Corporate Parkway
Suite 101
Macon, GA 31210
USA
Tel: +1 877 783 7337
Fax: +1 478 476 9867
e-mail: sales@verder-
us.com