

# **VERDERAIR VA 25**

## **UL-Listed**

## **Diaphragm Pumps**

859.0120

Rev. H  
EN

*For use in general fuel transfer applications. For professional use only.*

### **Model 850.0780, Evacuation and Transfer Pump**

*100 psi (0.7 MPa, 7.0 bar) Maximum Fluid Working Pressure*

*100 psi (0.7 MPa, 7.0 bar) Maximum Air Input Pressure*



#### **Important Safety Instructions**

Read all warnings and instructions in this manual. Save these instructions.

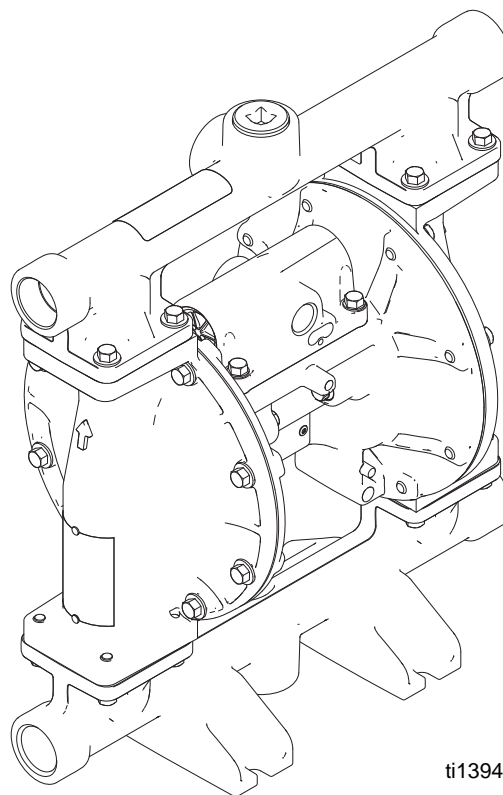

ti13946a



This symbol on the nameplate means the product is listed by Underwriters Laboratories Inc. (UL Standard No. 79 for Power-Operated Pumps for Petroleum Product Dispensing systems).



II 2 GD c IIC T4

## Contents

<b>Related Manual</b> .....	<b>2</b>	<b>Operation</b> .....	<b>13</b>
<b>Model Information</b> .....	<b>3</b>	Pressure Relief Procedure .....	13
<b>UL Listing Details</b> .....	<b>3</b>	Flush the Pump Before First Use .....	13
<b>ATEX Note</b> .....	<b>3</b>	Tighten Fasteners Before Setup .....	13
<b>Warnings</b> .....	<b>4</b>	Starting and Adjusting the Pump .....	13
<b>Installation</b> .....	<b>7</b>	Pump Shutdown .....	14
General Information .....	7	<b>Maintenance</b> .....	<b>15</b>
Tighten Fasteners Before Setup .....	7	Maintenance Schedule .....	15
Mounting .....	7	Lubrication .....	15
Grounding .....	7	Tighten Threaded Connections .....	15
Air Line .....	8	Flushing and Storage .....	15
Air Exhaust Ventilation .....	9	Torque Instructions .....	16
Fluid Supply Line .....	10	<b>Dimensions</b> .....	<b>17</b>
Fluid Outlet Line .....	11	<b>Performance Chart</b> .....	<b>18</b>
Fluid Inlet and Outlet Ports .....	11	<b>Technical Data</b> .....	<b>20</b>
Fluid Pressure Relief Valve .....	12	<b>Customer Services/Guarantee</b> .....	<b>21</b>

## Related Manual

Manual	Description
859.0089	VERDERAIR VA 25 Air-Operated Diaphragm Pump, Repair/Parts

## Model Information

Part	Matrix Identification Number	Maximum Working Pressure psi (MPa, bar)
850.0780	VA25AA-HYACHYTNUL	100 (0.7, 7.0)

VA25	A	A	HY	AC	HY	TN	UL
Pump Model, 1 inch ports, 50 gpm	Fluid Section	Air Section	TPE Seats	Acetal Balls	TPE Diaphragms	npt connections	UL-Listed

## UL Listing Details

Model 850.0780 is certified per UL 79 for use in pumping gasoline and gasoline/alcohol blends up to 10% ethanol, diesel fuel, fuel oil, and lubricating oil. This certification does not cover oil burner pumps; pumps for engine-powered automotive equipment; or pumps for use in mobile applications, chemical plants, utility plants, petroleum production facilities, and pipeline pump stations, nor does it cover the complete end user installation.

## ATEX Note

The muffler included with the pump is not approved for use in explosive atmosphere locations. ATEX applications require the use of a metal or conductive plastic muffler, or remote exhaust using static-free hoses or metal piping.

## Warnings

The following warnings are for the setup, use, grounding, maintenance, and repair of this equipment. The exclamation point symbol alerts you to a general warning and the hazard symbol refers to procedure-specific risk. When these symbols appear in the body of this manual, refer back to these warnings. Additional, product-specific warnings may be found throughout the body of this manual where applicable.



### WARNING



#### FIRE AND EXPLOSION HAZARD

When flammable fluids are present in the work area, such as gasoline and windshield wiper fluid, be aware that flammable fumes can ignite or explode. To help prevent fire and explosion:

- Use equipment only in well ventilated area.
- Eliminate all ignition sources; such as cigarettes and portable electric lamps.
- Keep work area free of debris, including rags and spilled or open containers of solvent and gasoline.
- Route exhaust away from all sources of ignition. If diaphragm ruptures, fluid may be exhausted with air. See **Air Exhaust Ventilation**, page 9.
- Do not plug or unplug power cords, or turn lights on or off when flammable fumes are present.
- Ground all equipment in the work area. See **Grounding** instructions.
- Use only grounded hoses.
- Hold gun firmly to side of grounded pail when triggering into pail.
- If there is static sparking or you feel a shock, **stop operation immediately**. Do not use equipment until you identify and correct the problem.
- Keep a working fire extinguisher in the work area.



**WARNING**



**EQUIPMENT MISUSE HAZARD**

Misuse can cause death or serious injury.

- Do not operate the unit when fatigued or under the influence of drugs or alcohol.
- Do not exceed the maximum working pressure or temperature rating of the lowest rated system component. See **Technical Data** in all equipment manuals.
- Use fluids and solvents that are compatible with equipment wetted parts. See **Technical Data** in all equipment manuals. Read fluid and solvent manufacturer's warnings. For complete information about your material, request MSDS from distributor or retailer.
- Do not leave the work area while equipment is energized or under pressure. Turn off all equipment and follow the **Pressure Relief Procedure** in this manual when equipment is not in use.
- Check equipment daily. Repair or replace worn or damaged parts immediately with genuine manufacturer's replacement parts only.
- Do not alter or modify equipment.
- Use equipment only for its intended purpose. Call your distributor for information.
- Route hoses and cables away from traffic areas, sharp edges, moving parts, and hot surfaces.
- Do not kink or over bend hoses or use hoses to pull equipment.
- Keep children and animals away from work area.
- Comply with all applicable safety regulations.



**PRESSURIZED EQUIPMENT HAZARD**

Fluid from the gun/dispense valve, leaks, or ruptured components can splash in the eyes or on skin and cause serious injury.

- Follow the **Pressure Relief Procedure** when you stop spraying and before cleaning, checking, or servicing equipment.
- Tighten all fluid connections before operating the equipment.
- Check hoses, tubes, and couplings daily. Replace worn or damaged parts immediately.



**PRESSURIZED ALUMINUM PARTS HAZARD**

Use of fluids that are incompatible with aluminum in pressurized equipment can cause serious chemical reaction and equipment rupture. Failure to follow this warning can result in death, serious injury, or property damage.

- Do not use 1,1,1-trichloroethane, methylene chloride, other halogenated hydrocarbon solvents or fluids containing such solvents.
- Many other fluids may contain chemicals that can react with aluminum. Contact your material supplier for compatibility.



## WARNING



### PLASTIC PARTS CLEANING SOLVENT HAZARD

Use only compatible water-based solvents to clean plastic structural or pressure-containing parts. Many solvents can degrade plastic parts and cause them to fail, which could cause serious injury or property damage. See **Technical Data** in this and all other equipment instruction manuals. Read fluid and solvent manufacturer's warnings.



### TOXIC FLUID OR FUMES HAZARD

Toxic fluids or fumes can cause serious injury or death if splashed in the eyes or on skin, inhaled, or swallowed.

- Read MSDS's to know the specific hazards of the fluids you are using.
- Route exhaust away from work area. If diaphragm ruptures, fluid may be exhausted with air.
- Store hazardous fluid in approved containers, and dispose of it according to applicable guidelines.



### BURN HAZARD

Equipment surfaces and fluid that's heated can become very hot during operation. To avoid severe burns:

- Do not touch hot fluid or equipment.



### PERSONAL PROTECTIVE EQUIPMENT

You must wear appropriate protective equipment when operating, servicing, or when in the operating area of the equipment to help protect you from serious injury, including eye injury, inhalation of toxic fumes, burns, and hearing loss. This equipment includes but is not limited to:

- Clothing and respirator as recommended by the fluid and solvent manufacturer
- Protective eyewear, gloves, and hearing protection

# Installation





## General Information

- The Typical Installations shown in FIG. 3 and FIG. 4 are only guides for selecting and installing system components. Contact your distributor for assistance in planning a system to suit your needs.
- Installation and use must be in accordance with the Flammable and Combustible Liquids Code (NFPA 30) and Automotive and Marine Service Station Code (NFPA 30a) and must comply with all local, state, and federal codes.
- All pipe joints must be made tight with UL listed gasoline-resistant pipe compound.

## Tighten Fasteners Before Setup

Before using the pump for the first time, check and retorque all external fasteners. Follow **Torque Instructions**, page 16.



## Mounting

						
<ul style="list-style-type: none"> <li>• The pump exhaust air may contain contaminants. Ventilate to a remote area. See <b>Air Exhaust Ventilation</b> on page 9.</li> <li>• Never move or lift a pump under pressure. If dropped, the fluid section may rupture. Always follow the <b>Pressure Relief Procedure</b> on page 13 before moving or lifting the pump.</li> </ul>						

1. Be sure the mounting surface can support the weight of the pump, hoses, and accessories, as well as the stress caused during operation.

2. For all mountings, be sure the pump is bolted directly to the mounting surface.
3. For ease of operation and service, mount the pump so the air valve, air inlet, fluid inlet and fluid outlet ports are easily accessible.
4. Rubber Foot Mounting Kit 819.4333 is available to reduce noise and vibration during operation.

## Grounding

						
<p>This pump must be electrically grounded using the grounding conductor provided. Improper grounding can cause hazardous operation.</p>						

The equipment must be grounded. Grounding reduces the risk of static and electric shock by providing an escape wire for the electrical current due to static build up or in the event of a short circuit.

**Pump:** See FIG. 1. Loosen the grounding screw (GS). Insert one end of a 12 ga. minimum ground wire (R) behind the grounding screw and tighten the screw securely. Connect the clamp end of the ground wire to a true earth ground. A ground wire and clamp, Part 819.0157, is available.

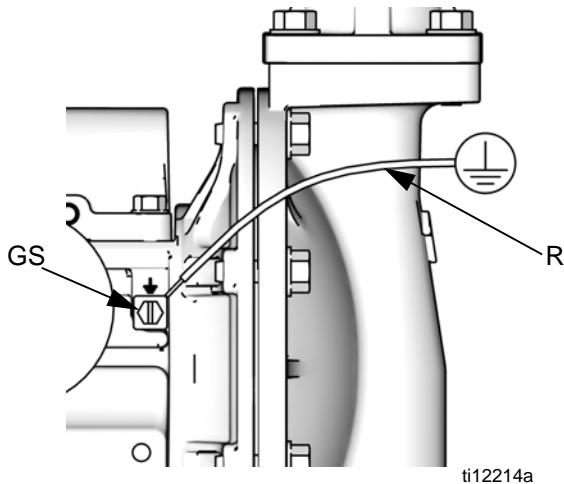

**Fig. 1. Ground screw and wire**

**Air and fluid hoses:** Use only grounded hoses with a maximum of 500 ft (150 m) combined hose length to ensure grounding continuity.

**Air compressor:** Follow manufacturer's recommendations.

**Fluid supply container:** Follow local code.

**Solvent pails used when flushing:** Follow local code. Use only conductive metal pails, placed on a grounded surface. Do not place the pail on a nonconductive surface, such as paper or cardboard, which interrupts grounding continuity.

**Suction device nozzle:** Bond to metal container from which it is suctioning by firm metal-to-metal contact to a properly grounded supply hose and pump.

**Piping, valves, and fittings:** Use only electrically conductive materials. Bond and ground per code.

Check your system electrical continuity after the initial installation, and then set up a regular schedule for checking continuity to be sure proper grounding is maintained.

## Air Line

Install the air line accessories as shown in FIG. 3 and FIG. 4. Mount these accessories on the wall or on a bracket. Be sure the air line supplying the accessories is grounded.

1. Install an air regulator (C) and gauge to control the fluid pressure. Locate it close to the pump.
2. Locate a bleed-type master air valve (B) close to the pump and use it to relieve trapped air. Be sure the valve is easily accessible from the pump and located downstream from the regulator.

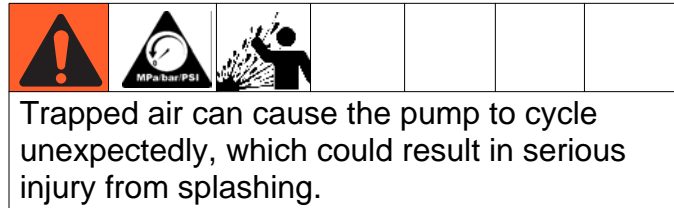

3. Locate another master air valve (E) upstream from all air line accessories and use it to isolate them during cleaning and repair.
4. An air line filter (F) removes harmful dirt and moisture from the compressed air supply.
5. Install a grounded, flexible air hose (A) between the accessories and the 1/2 npt(f) pump air inlet (D). Use a minimum 3/8 in. (10 mm) ID air hose.



## Air Exhaust Ventilation



Be sure to read and follow the **TOXIC FLUID OR FUMES HAZARD** warnings, page 6, and **FIRE AND EXPLOSION HAZARD** warnings, page 4, before operating this pump. You must vent the exhaust away from people, animals, food handling areas, and all sources of ignition when pumping flammable or hazardous fluids. Vent in accordance with local codes, or in the absence of local codes, an industry or nationally recognized code having jurisdiction over the specific installation.

The air exhaust port is 3/4 npt(f). Do not restrict the air exhaust port. Excessive exhaust restriction can cause erratic pump operation.

1. Remove the muffler (T) from the pump air exhaust port.
2. Install a grounded air exhaust hose (U) and connect the muffler (T) to the other end of the hose. The minimum size for the air exhaust hose is 3/4 in. (19 mm) ID. If a hose longer than 15 ft (4.57 m) is required, use a larger diameter hose. Avoid sharp bends or kinks in the hose.
3. Place a container at the end of the air exhaust line to catch fluid in case a diaphragm ruptures. Locate the container away from all sources of ignition, including pilot lights and waste materials. If the diaphragm ruptures, the fluid being pumped will exhaust with the air.

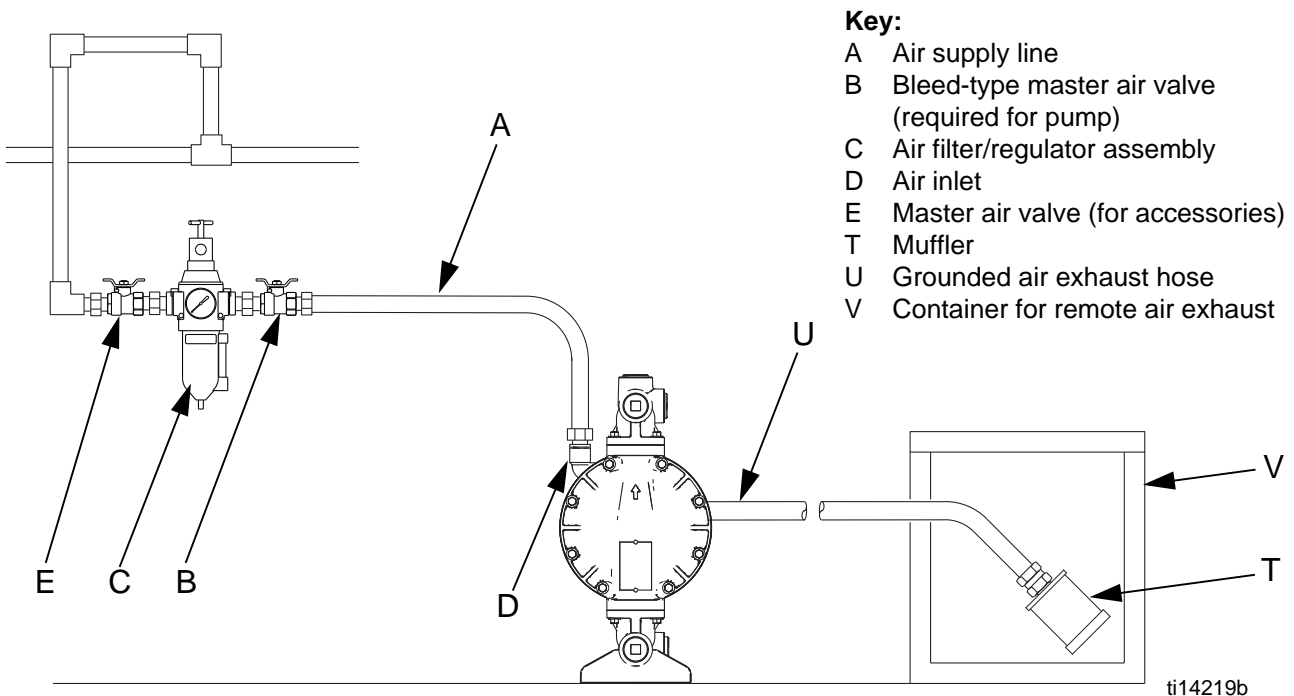

**FIG. 2. Vent exhaust air**

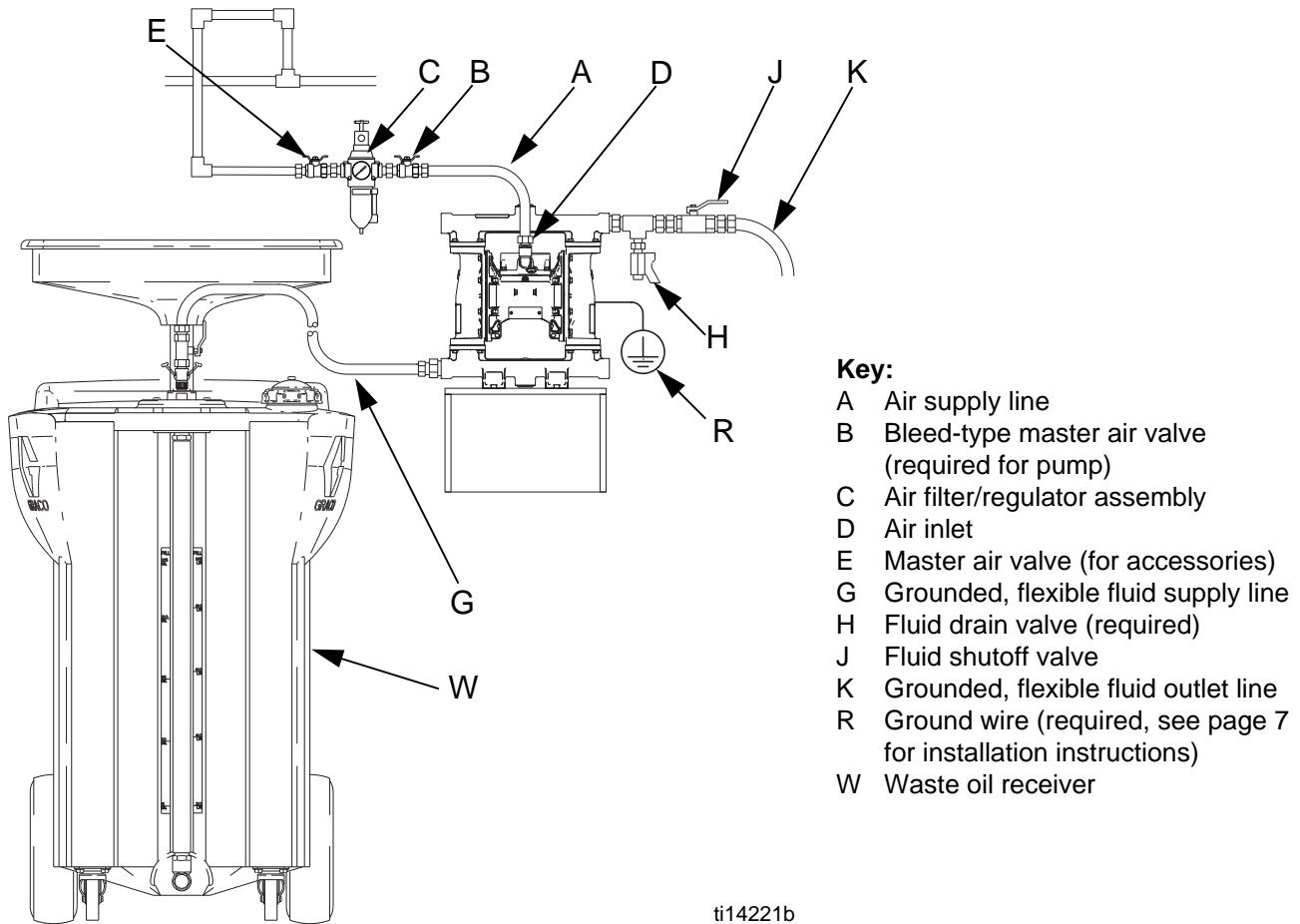

**FIG. 3. Waste oil or general fluid transfer, typical installation**

## Fluid Supply Line

See FIG. 3 and FIG. 4, pages 10 through 11.

1. Use grounded, flexible fluid supply lines (G). See **Grounding**, page 7.
2. If the inlet fluid pressure to the pump is more than 25% of the outlet working pressure, the ball check valves will not close fast enough, resulting in inefficient pump operation. Excessive inlet fluid pressure also will shorten diaphragm life. Approximately 3 - 5 psi (0.02- 0.03 MPa, 0.21-0.34 bar) should be adequate for most materials.
3. For maximum suction lift (wet and dry), see on page 18. For best results, always install

the pump as close as possible to the material source.

4. For a Waste Oil Receiver Evacuation System, connect an appropriate suction hose (G) between the pump fluid inlet and the waste oil receiver. See FIG. 3.
5. For a Gear Oil Evacuation System, install a control valve (M), flexible hose (L), and an appropriate wand (N) in each service bay and connect to the fluid suction line (G). See FIG. 4, page 11.

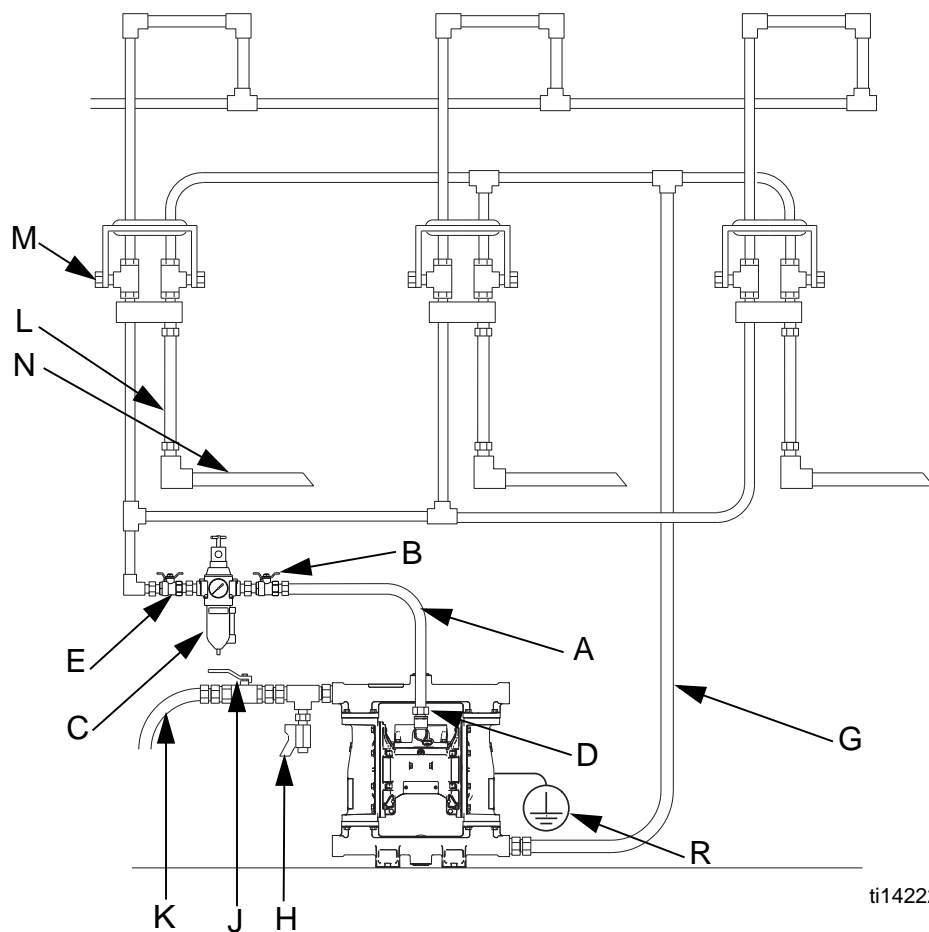

**Key:**

- A Air supply line
- B Bleed-type master air valve (required for pump)
- C Air filter/regulator assembly
- D Air inlet
- E Master air valve (for accessories)
- G Fluid suction line, flexible hose
- H Fluid drain valve (required)
- J Fluid shutoff valve
- K Waste oil line (to storage tank)
- L Fluid line, flexible hose
- M Control valve
- N Suction wand
- R Ground wire (required, see page 7 for installation instructions)

ti14222b

**FIG. 4. Gear oil evacuation, typical installation**

## Fluid Outlet Line

See FIG. 3 and FIG. 4, pages 10 through 11.

1. Use grounded fluid hoses (G, K). See **Grounding**, page 7.
2. The pump fluid outlet is 1 in. npt(f). Screw the fluid fitting into the pump outlet securely.
3. A fluid drain valve (H) is required in your system to relieve pressure in the hose and dispense valve. Install the valve close to the pump fluid outlet.
4. Install a shutoff valve (J) in the fluid outlet line.

## Fluid Inlet and Outlet Ports

**NOTE:** Remove and reverse the manifold(s) to change the orientation of inlet or outlet port(s). Follow **Torque Instructions**, page 16.

The fluid inlet and outlet manifolds each have four 1 in. npt(f) threaded ports. Close off the unused ports, using the supplied plugs.

## Fluid Pressure Relief Valve



Some evacuation and transfer systems may require installation of a pressure relief valve at the pump outlet to prevent overpressurization and rupture of the pump or hose. Fluid Pressure Relief Kit 819.6479 is available. See FIG. 5. Relief pressure is between 150 and 180 psi (1.03 MPa-1.24 MPa, 10.3-12.4 bar).

Thermal expansion of fluid in the outlet line can cause overpressurization. Thermal expansion can occur when using long fluid lines exposed to sunlight or ambient heat, or when pumping from a cool to a warm area (for example, from an underground tank).



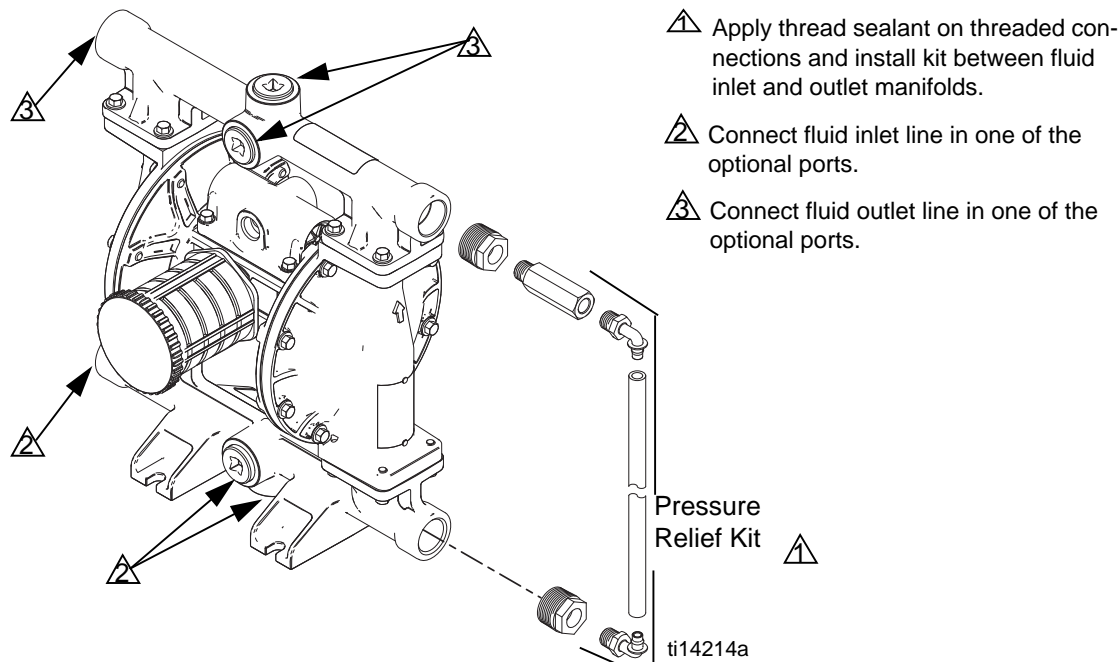

Overpressurization also can occur if the pump is used to feed fluid to a piston pump, and the intake valve of the piston pump does not close, causing fluid to back up in the outlet line.



**FIG. 5. Optional Fluid Pressure Relief Kit 819.6479, for Model 850.0780**

# Operation

## Pressure Relief Procedure

						
<p>Trapped air can cause the pump to cycle unexpectedly, which could result in serious injury from splashing.</p>						

1. Shut off the air supply to the pump.
2. Open the dispensing valve (if used).
3. Open the fluid drain valve to relieve fluid pressure, having a waste container ready to catch the drainage.

## Flush the Pump Before First Use

The pump was tested in water. If water could contaminate the fluid you are pumping, flush the pump thoroughly with a compatible solvent. See **Flushing and Storage**, page 15.

## Tighten Fasteners Before Setup

Before using the pump for the first time, check and retorquer all external fasteners. Follow **Torque Instructions**, page 16. After the first day of operation, retorquer the fasteners.

## Starting and Adjusting the Pump

1. Be sure the pump is properly grounded. Refer to **Grounding** on page 7.
2. Check fittings to be sure they are tight. Use a compatible liquid thread sealant on male threads. Tighten the fluid inlet and outlet fittings securely.

**NOTE:** If fluid inlet pressure to the pump is more than 25% of outlet working pressure, the ball check valves will not close fast enough, resulting in inefficient pump operation.

## Waste Oil Receiver Evacuation Systems or General Fluid Transfer Applications

See FIG. 3.

1. Close the pump air regulator (C) and the bleed-type master air valves (B, E).
2. Connect the pump suction hose (G) to the pump fluid inlet. Attach a fluid quick coupler to the other end of the hose, then connect the coupler to the outlet fitting of the waste oil receiver.
3. Place the end of the fluid hose into an appropriate container.
4. Close the fluid drain valve (H). Open the fluid shutoff valve (J).
5. Connect the air supply line to the pump air inlet (D).
6. Open the bleed-type master air valves (B, E).
7. Slowly increase air pressure with the air regulator (C) until the pump starts to cycle. Allow the pump to cycle slowly until all air is pushed out of the lines and the pump is primed.

**NOTE:** Use lowest possible air pressure to prime, just enough to cycle the pump. If the pump does not prime as expected, turn air pressure **DOWN**.

<b>NOTICE</b>
<p><b>When replacing old models of VA 25:</b> The new VA 25 operates more efficiently than did the old models. <b>Reduce</b> air inlet pressure by approximately <b>20 percent</b> to maintain an equivalent fluid output.</p>

## Gear Oil Evacuation Systems

See FIG. 4.

1. Close the pump air regulator (C) and the bleed-type master air valves (B, E).
2. Attach an appropriate wand to the suction hose. Place the wand in the differential or fluid to be pumped.
3. Place the end of the fluid hose into an appropriate container.
4. Close the fluid drain valve (H). Open the fluid shutoff valve (J).
5. Connect the air supply line to the pump air inlet (D).
6. Open the bleed-type master air valves (B, E).
7. Set the air regulator (C) to about 50 psi (350 kPa, 3.5 bar).
8. Pull the control valve handle (M) down to start the pump.

**NOTE:** Adjust the air regulator (C). Allow the pump to cycle slowly until all air is pushed out of the lines and the pump is primed. Use lowest possible air pressure to prime, just enough to cycle the pump. If the pump does not prime as expected, turn air pressure **DOWN**.

9. Push the control valve handle (M) up when finished. Place the wand in the holder on the control valve.

**NOTE:** Be sure the control valve handle is closed when evacuation is completed. Failure to close it may prevent other service bays from developing full suction.

## Pump Shutdown

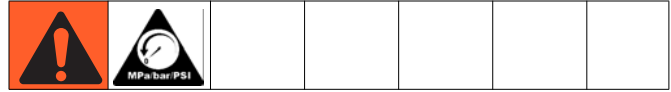

At the end of the work shift and before you check, adjust, clean or repair the system, follow **Pressure Relief Procedure**, page 13.

## Maintenance

### Maintenance Schedule

Establish a preventive maintenance schedule, based on the pump's service history. Scheduled maintenance is especially important to prevent spills or leakage due to diaphragm failure.

### Lubrication

The pump is lubricated at the factory. It is designed to require no further lubrication for the life of the pump. There is no need to add an in-line lubricator under normal operating conditions.

### Tighten Threaded Connections

Before each use, check all hoses for wear or damage and replace as necessary. Check to be sure all threaded connections are tight and leak-free. Check fasteners. Tighten or retorque as necessary. Although pump use varies, a general guideline is to retorque fasteners every two months. See **Torque Instructions**, page 16.

## Flushing and Storage



- Flush before fluid can dry in the equipment, at the end of the day, before storing, and before repairing equipment.
- Flush at the lowest pressure possible. Check connectors for leaks and tighten as necessary.
- Flush with a fluid that is compatible with the fluid being dispensed and the equipment wetted parts.

Flush the pump often enough to prevent the fluid you are pumping from drying or freezing in the pump and damaging it. Use a compatible solvent.

Always flush the pump and relieve the pressure before storing it for any length of time.

## Torque Instructions

**NOTE:** Fluid cover and manifold fasteners have a thread-locking adhesive patch applied to the threads. If this patch is excessively worn, the fasteners may loosen during operation. Replace screws with new ones or apply medium-strength (blue) Loctite or equivalent to the threads.

If fluid cover or manifold fasteners have been loosened, it is important to torque them using the following procedure to improve sealing.

**NOTE:** Always completely torque fluid covers before torquing manifolds.

Start all fluid cover screws a few turns. Then turn down each screw just until head contacts cover. Then turn each screw by 1/2 turn or less working in a crisscross pattern to specified torque. Repeat for manifolds.

**Fluid cover and manifold fasteners:**  
100 in-lb (11.3 N•m)

Retorque the air valve fasteners (V) in a crisscross pattern to 80 in-lb (9.0 N•m).

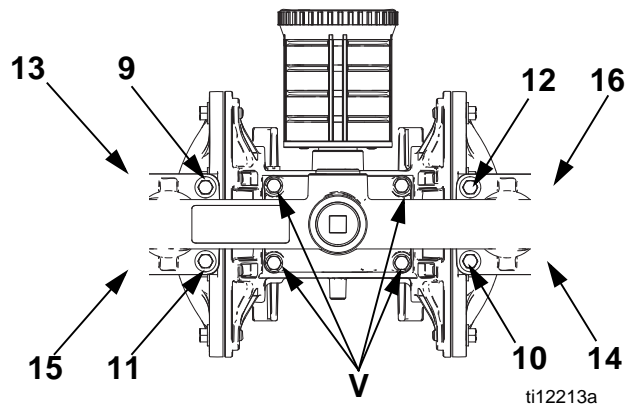
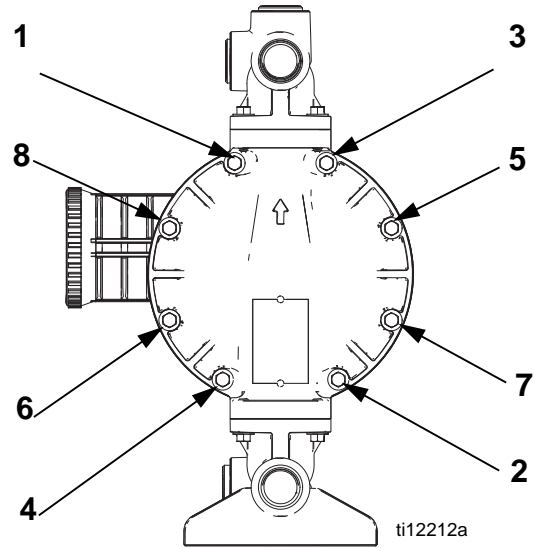

**FIG. 6. Torque sequence**



**Dimensions**

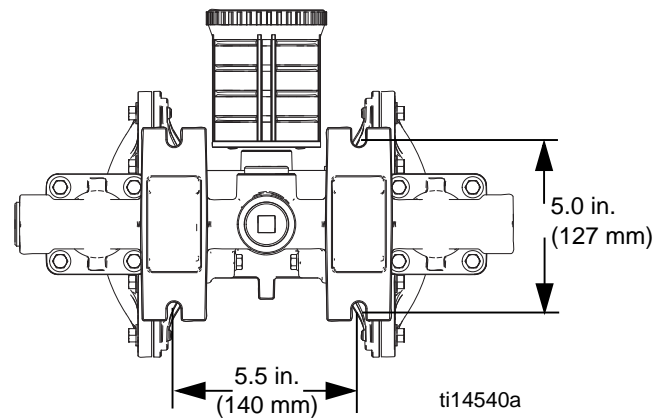
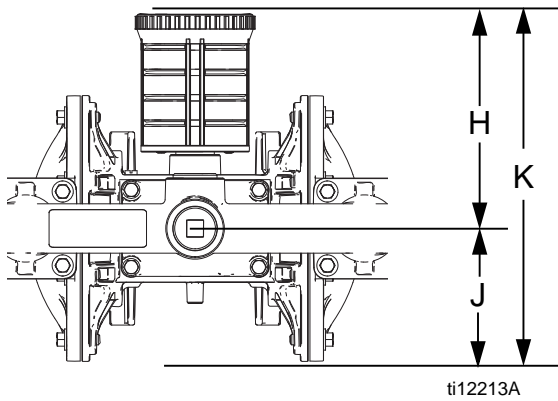
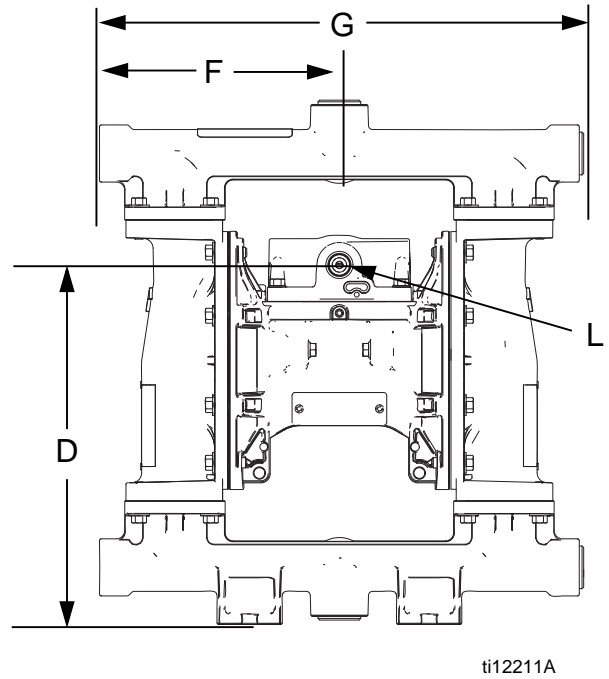
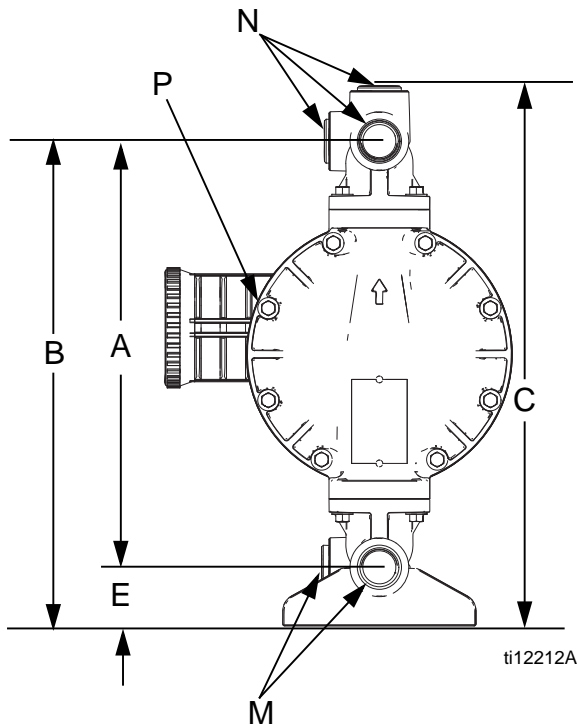

- A** ..... 12.7 in. (323 mm)
- B** ..... 14.4 in. (366 mm)
- C** ..... 15.9 in. (404 mm)
- D** ..... 10.9 in. (277 mm)
- E** ..... 1.8 in. (46 mm)
- F**..... 7.3 in. (185 mm)
- G**..... 14.7 in. (373 mm)
- H**..... 6.1 in. (155 mm)
- J**..... 3.9 in. (99 mm)

- K**..... 10.0 in. (254 mm)
- L**..... 1/2 npt(f) air inlet
- M** .... 1 in. npt(f) fluid inlet ports (4)
- N**..... 1 in. npt(f) fluid outlet ports (4)
- P**..... 3/4 npt(f) air exhaust port

## Performance Chart

**Test Conditions:** Pump tested in water with inlet submerged.

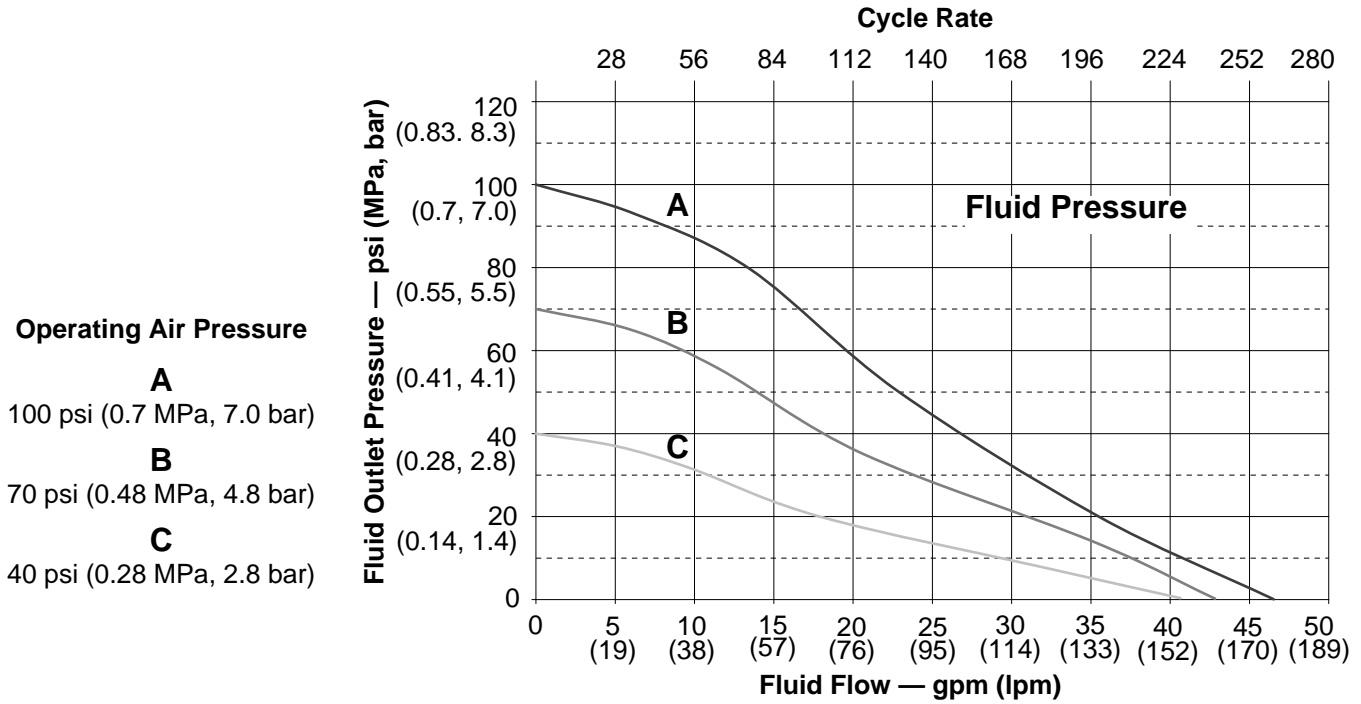

### How to Read the Charts

1. Locate fluid flow rate along bottom of chart.
2. Follow vertical line up to intersection with selected operating air pressure curve.
3. Follow left to scale to read **fluid outlet pressure** (top chart) or **air consumption** (bottom chart).

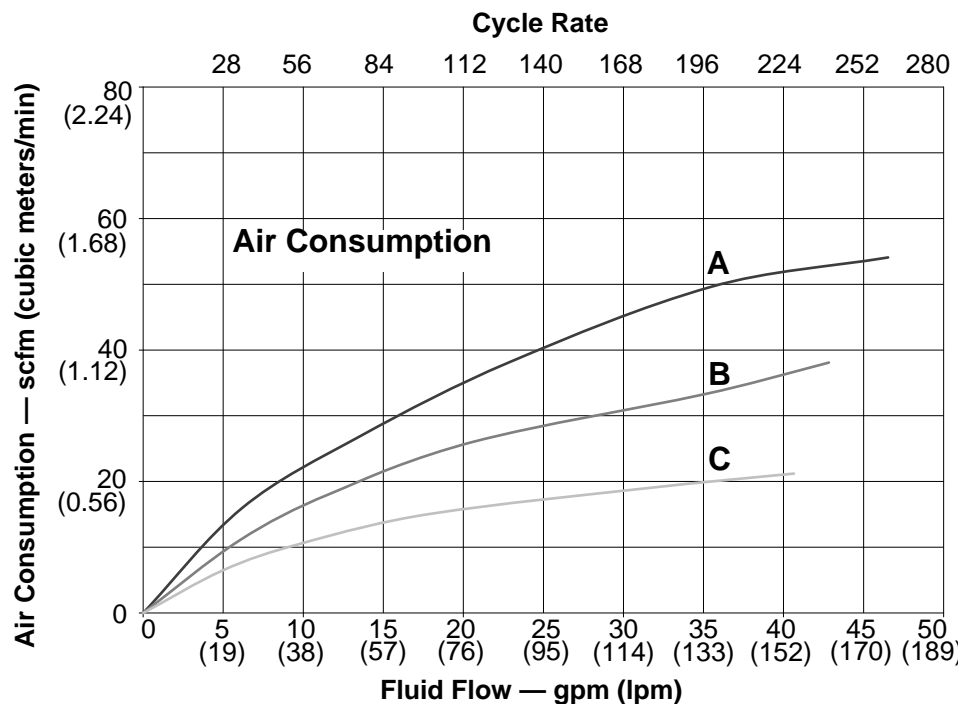



## EU-DECLARATION OF CONFORMITY

EU-CONFORMITEITSVERKLARING, DÉCLARATION UE DE CONFORMITÉ, EU-KONFORMITÄTSERKLÄRUNG, DICHIARAZIONE DI CONFORMITÀ UE, EU-OVERENSTEMMELSESERKLÆRING, ΔΗΛΩΣΗ ΣΥΜΜΟΡΦΩΣΗΣ ΕΕ, DECLARAÇÃO UE DE CONFORMIDADE, DECLARACIÓN UE DE CONFORMIDAD, EU-VAATIMUSTENMUKAISUUSVAKUUTUS, EU-FÖRSÄKRAN OM ÖVERENSSTÄMMELSE, EU PROHLÁŠENÍ O SHODĚ, ELI VASTAVUSDEKLARATSIOON, EU-MEGFELELŐSÉGI NYILATKOZAT, ES ATBILSTĪBAS DEKLARĀCIJA, ES ATTIKTIKTES DEKLARACIJA DEKLARACIJA ZGODNOSTI UE, DIKJARAZZJONI TA' KONFORMITÀ TAL-UE, EU IZJAVA O SKLADNOSTI, EU VYHLÁSENIE O ZHODE, ЕС ДЕКЛАРАЦИЯ ЗА СЪОТВЕТСТВИЕ, DECLARAȚIA UE DE CONFORMITATE

### Model

Modèle, Modell, Modello, Μοττέλο, Modelo, Malli, Mudel, Modelis, Mudell, Модел, Samhail

VERDERAIR VA 25

### Part

Bestelnr., Type, Teil, Codice, Del, Μέρος, Peça, Referencia, Osa, Součást, Részegység, Dajla, Dalis, Część, Taqsim, Čast', Част, Páirt, Parte

810.0905, 810.0906, 850.0072\*, 850.0073\*, 850.0074\*, 850.0078, 850.0081, 850.0082\*–850.0084\*, 850.0191–850.0194, 850.0248, 850.0255, 850.0265, 850.0283, 850.0331, 850.0371\*, 850.0382, 850.0419, 850.0429, 850.0430, 850.0535, 850.0545, 850.0563, 850.0569, 850.0662, 850.0780, 850.0099\*, 850.0100\*, 850.2680, 850.2855, 850.2925\*, 850.2935\*, 850.2945\*, 850.3100\*, 850.3122\*, 850.3128\*, 850.3134\*, 850.3282\*, 850.3380\*, 850.3402\*, 850.3414\*, 850.6346, 850.6976\*, 850.6980–850.6982, 850.7007, 850.7011\*, 850.7012\*, 850.7048\*, 850.7049\*, 850.8000\*–850.8007\*, 850.8008–850.8014, 850.8015\*, 850.8016\*, 850.8017–850.8022, 850.8023\*, 850.8031–850.8063, 850.8064–850.8088\*, 850.8089–850.8094, 850.8095\*, 850.8096\*–850.8098, 850.8100\*, 850.8101, 850.8145 (\*Do not have ATEX approval)

### Complies With The EC Directives:

Voldoet aan de EG-richtlijnen, Conforme aux directives CE, Entspricht den EG-Richtlinien, Conforme alle direttive CE, Overholder EF-direktiverne, Σύμφωνα με τις Οδηγίες της ΕΚ, Em conformidade com as Directivas CE, Cumple las directivas de la CE, Täyttää EY-direktiivien vaatimukset, Uppfyller EG-direktiven, Shoda se směrnicemi ES, Vastab EU direktiividele, Kielégíti az EK irányelvek követelményeit, Atbilst EK direktívam, Attinka šias ES direktivas, Zgodność z Dyrektywami UE, Konformi mad-Direttivi tal-KE, V skladu z direktivami ES, Je v súlade so smernicami ES, Съвместимост с Директиви на ЕО, Tá ag teacht le Teoracha an CE, Respectá directivele CE

2006/42/EC Machinery Safety Directive

2014/34/EC ATEX Directive (Ex II 2 GD c II C T4) - Tech File stored with NB 0359

(See Part No. above for corresponding ATEX approved pumps.)

### Standards Used:

Gebruikte maatstaven, Normes respectées, Verwendete Normen, Norme applicate, Anvendte standarder, Πρότυπα που χρησιμοποιήθηκαν, Normas utilizadas, Normas aplicadas, Sovellettavat standardit, Tillämpade standarder, Použité normy, Rakendatud standardid, Alkalmazott szabványok, Izmantotie standarti, Taikyti standartai, Užyte normy, Standards Užati, Uporabljeni standardi, Použité normy, Използвани стандарти, Caighdeán arna n-úsáid, Standarde utilizate

EN 1127-1 ISO 12100-2

EN 13463-1 ISO 9614-2

EN 13463-5

### Notified Body for Directive

Aangemelde instantie voor richtlijn, Organisme notifié pour la directive, Benannte Stelle für diese Richtlinie, Ente certificatore della direttiva, Bemyndiget organ for direktiv, Διακοσμημένο όργανο Οδηγίας, Organismo notificado relativamente à directiva, Organismo notificado de la directiva, Direktiivin mukaisesti ilmoitettu tarkastuslaitos, Anmält organ för direktivet, Úředně oznámený orgán pro směrnici, Teavitatud asutus (direktiivi järgi), Az irányelvvvel kapcsolatban értesített testület, Pilnvarotā iestāde saskaņā ar direktīvu, Apie direktīvu Informuota institūcija, Ciało powiadomione dla Dyrektywy, Korp avzāt bid-Direttiva, Priglašeni organ za direktivo, Notifikovaný orgán pre smernicu, Нотифициран орган за Директива, Comhlacht ar tugadh fógra dó, Organism notificat în conformitate cu directiva

--	--	--

### Approved By:

Goedgekeurd door, Approuvé par, Genehmigt von, Approvato da, Godkendt af, Έγκριση από, Aprovado por, Aprobado por, Hyväksynyt, Intygas av, Schwáil, Kinnitanud, Jóváhagyta, Apstiprināts, Patvirtino, Zatwierdzone przez, Approvat minn, Odobril, Schwálené, Odobreno ot, Faofa ag, Aprobat de

Werner Bosman  
Managing Director

16 February 2017

### VERDER BV

Leningradweg 5  
9723 TP Groningen  
NETHERLANDS

859.0086

B

This declaration of conformity is issued under the sole responsibility of the manufacturer. Deze conformiteitsverklaring wordt verstrekt onder volledige verantwoordelijkheid van de fabrikant. La présente déclaration de conformité est établie sous la seule responsabilité du fabricant. Die alleinige Verantwortung für die Ausstellung dieser Konformitätserklärung trägt der Hersteller. La presente dichiarazione di conformità è rilasciata sotto la responsabilità esclusiva del fabbricante. Denne overensstemmelseserklæring udstedes på fabrikantens ansvar. Η παρούσα δήλωση συμμόρφωσης εκδίδεται με αποκλειστική ευθύνη του κατασκευαστή. A presente declaração de conformidade é emitida sob a exclusiva responsabilidade do fabricante. La presente declaración de conformidad se expide bajo la exclusiva responsabilidad del fabricante. Tāma vaatimustenmukaisuusvakuutus on annettu valmistajan yksinomaista vastuulla. Denna försäkrän om överensstämmelse utfärdas på tillverkarens eget ansvar. Toto prohlášení o shodě se vydává na výhradní odpovědnost výrobce. Käesolev vastavusdeklaratsioon on välja antud tootja ainuvastutusel. Ezt a megfelelőségi nyilatkozatot a gyártó kizárólagos felelőssége mellett adják ki. Ši atbilstības deklarācija ir izdota vienīgi uz ražotāja atbildību. Ši atitikties deklaracija išduota tik gamintojo atsakomybe. Niniejsza deklaracja zgodności wydana zostaje na wyłączną odpowiedzialność producenta. Din iddikjarazzjoni tal-konformità qiegħda tinfereġ taħt ir-responsabbiltà unika tal-manifattur. Ta izjava o skladnosti je izdana na lastno odgovornost proizvajalca. Toto vyhlásenie o zhode sa vydáva na výhradnú zodpovednosť výrobcu. Настоящата декларация за съответствие е издадена на отговорността на производителя. Prezenta declarație de conformitate este emisă pe răspunderea exclusivă a producătorului.

## Technical Data

Maximum fluid working pressure . . . . .	100 psi (0.7 MPa, 7.0 bar)
Air pressure operating range . . . . .	20-100 psi (0.14-0.7 MPa, 1.4-7.0 bar)
Air consumption at 70 psi (0.48 MPa, 4.8 bar), 20 gpm (76 lpm) . . . . .	25 scfm
Fluid displacement per cycle . . . . .	0.17 gal. (0.64 liters)
Flooded volume . . . . .	0.375 gal. (1.42 liters)
Maximum values with water as media under submerged inlet conditions at ambient temperature:	
Maximum air consumption . . . . .	64 scfm
Maximum free-flow delivery . . . . .	50 gpm (189 lpm)
Maximum pump speed . . . . .	275 cpm
Maximum suction lift (varies widely based on ball/seat material and wear, operating speed, material properties, and other variables) . . .	16 ft (4.9 m) dry, 29 ft (8.8 m) wet
Maximum size pumpable solids . . . . .	1/8 in. (3.2 mm)
Recommended cycle rate for continuous use . . . . .	93 - 140 cpm
Recommended cycle rate for circulation systems . . . . .	20 cpm
Sound Power*	
at 70 psi (0.48 MPa, 4.8 bar) and 50 cpm . . . . .	78 dBa
at 100 psi (0.7 MPa, 7.0 bar) and full flow . . . . .	90 dBa
Sound Pressure**	
at 70 psi (0.48 MPa, 4.8 bar) and 50 cpm . . . . .	84 dBa
at 100 psi (0.7 MPa, 7.0 bar) and full flow . . . . .	96 dBa
Operating temperature range . . . . .	10°F to 150°F (-12°C to 65°C)
Air inlet size . . . . .	1/2 npt(f)
Fluid inlet size . . . . .	1 in. npt(f)
Fluid outlet size . . . . .	1 in. npt(f)
Weight . . . . .	23 lb. (10.5 kg)
Wetted parts . . . . .	aluminum, TPC-ET, Acetal, PTFE
Non-wetted external parts . . . . .	aluminum, coated carbon steel

\* Sound power measured per ISO-9614-2.

\*\* Sound pressure was tested 3.28 ft (1 m) from equipment.

*All trademarks mentioned in this manual are the property of their respective owners.*

## **Customer Services/Guarantee**

### **CUSTOMER SERVICES**

If you require spare parts, please contact your local distributor, providing the following details:

- Pump Model
- Type
- Serial Number, and
- Date of First Order.

### **GUARANTEE**

All VERDER pumps are warranted to the original user against defects in workmanship or materials under normal use (rental use excluded) for two years after purchase date. This warranty does not cover failure of parts or components due to normal wear, damage or failure which in the judgement of VERDER arises from misuse.

Parts determined by VERDER to be defective in material or workmanship will be repaired or replaced.

### **LIMITATION OF LIABILITY**

To the extent allowable under applicable law, VERDER's liability for consequential damages is expressly disclaimed. VERDER's liability in all events is limited and shall not exceed the purchase price.

### **WARRANTY DISCLAIMER**

VERDER has made an effort to illustrate and describe the products in the enclosed brochure accurately; however, such illustrations and descriptions are for the sole purpose of identification and do not express or imply a warranty that the products are merchantable, or fit for a particular purpose, or that the products will necessarily conform to the illustration or descriptions.

### **PRODUCT SUITABILITY**

Many regions, states and localities have codes and regulations governing the sale, construction, installation and/or use of products for certain purposes, which may vary from those in neighboring areas. While VERDER attempts to assure that its products comply with such codes, it cannot guarantee compliance, and cannot be responsible for how the product is installed or used. Before purchasing and using a product, please review the product application as well as the national and local codes and regulations, and be sure that product, installation, and use complies with them.

**Austria**  
Verder Austria  
Eitnergasse 21/Top 8  
A-1230 Wien  
AUSTRIA  
Tel: +43 1 86 51 074 0  
Fax: +43 1 86 51 076  
e-mail: office@verder.at

**Belgium**  
Verder nv  
Kontichsesteenweg 17  
B-2630 Aartselaar  
BELGIUM  
Tel: +32 3 877 11 12  
Fax: +32 3 877 05 75  
e-mail: info@verder.be

**China**  
Verder Shanghai Instruments and Equipment Co., Ltd  
Building 8 Fuhai Business Park No. 299  
Bisheng Road, Zhangjiang Hiteck Park  
Shanghai 201204  
CHINA  
Tel: +86 21 33932950  
Fax: +86 21 33932955  
e-mail: info@verder.cn

---

**Bulgaria**  
Verder Bulgaria Ltd  
Vitosh department,  
Manastriski Livadi Zapad  
district,  
110 Bulgaria Blvd., 2-nd  
Floor, apt. 15-16,  
1618 - Sofia  
BULGARIA  
Tel: 0878407370  
Fax: 02 9584085  
email: office@verder.bg

**Czech Republic**  
Verder s.r.o.  
Vodnanská 651/6 (vchod  
Chlumecka 15)  
198 00 Praha 9-Kyje  
CZECH REPUBLIC  
Tel: +420 261 225 386-7  
Web: <http://www.verder.cz>  
e-mail: info@verder.cz

**Denmark**  
Verder A/S  
Sales Denmark  
Leningradweg 5  
NL 9723 TP Groningen  
THE NETHERLANDS  
Tel: +45 3636 4600  
e-mail: info@verder.dk

**France**  
Verder France  
8 Allée Rosa Luxembourg  
Immeulde Arizona  
95610 Eragny sur Oise  
FRANCE  
Tel: +33 173 43 98 41  
Fax: +33 134 64 44 50  
e-mail: info@verder.fr

---

**Germany**  
Verder Deutschland GmbH  
Retsch-Allee 1-5  
42781 Haan  
GERMANY  
Tel: 02104/2333-200  
Fax: 02104/2333-299  
e-mail: info@verder.de

**Hungary**  
Verder Hongary Kft  
Budafoke ut 187 - 189  
HU-1117 Budapest  
HUNGARY  
Tel: 0036 1 3651140  
Fax: 0036 1 3725232  
e-mail: info@verder.hu

**India**  
Verder India Pumps Pvt  
Ltd.  
Plot No-3B, D-1 Block,  
MIDC Chinchwad,  
Pune - 411019  
INDIA  
e-mail:  
Sales@verder.co.in  
[www.verder.co.in](http://www.verder.co.in)

**Italy**  
Verder Italia  
Via Maestri Del lavoro, 5  
02100 Vazia, Rieti  
ITALY  
Tel: +39 07 46 229064  
e-mail: info@verder.it

---

**The Netherlands**  
Verder BV  
Leningradweg 5  
NL 9723 TP Groningen  
THE NETHERLANDS  
Tel: +31 50 549 59 00  
Fax: +31 50 549 59 01  
e-mail: info@verder.nl

**Poland**  
Verder Polska  
ul.Porcelanowa 23  
PL-40 036 Katowice  
POLAND  
Tel: +48 32 78 15 032  
Fax: +48 32 78 15 034  
e-mail: verder@verder.pl

**Romania**  
Verder România  
Drumul Balta Doamnei  
no 57-61  
Sector 3  
CP 72-117  
032624 Bucuresti  
ROMANIA  
Tel: +40 21 335 45 92  
Fax: +40 21 337 33 92  
e-mail: office@verder.ro

**Slovak Republik**  
Verder Slovakia s.r.o.  
Silacska 1  
SK-831 02 Bratislava  
SLOVAK REPUBLIK  
Tel: +421 2 4463 07 88  
Fax: +421 2 4445 65 78  
e-mail: info@verder.sk

---

**South Africa**  
Verder SA  
197 Flaming Rock Avenue  
Northlands Business Park  
Newmarket Street  
ZA Northriding  
SOUTH AFRICA  
Tel: +27 11 704 7500  
Fax: +27 11 704 7515  
e-mail: info@verder.co.za

**Switzerland**  
Verder Deutschland GmbH  
Sales Switzerland  
Retsch-Allee 1-5  
D-42781 Haan  
GERMANY  
Tel: +41 (0)61 331 33 13  
Fax: +41 (0)61 331 63 22  
e-mail: info@verder.ch

**United Kingdom**  
Verder UK Ltd.  
Unit 3 California Drive  
Castleford, WF10 5QH  
UNITED KINGDOM  
Tel: +44 (0) 1924 221 001  
Fax: +44 (0) 1132 465 649  
e-mail: info@verder.co.uk

**United States of America**  
Verder Inc.  
312 Corporate Parkway  
Suite 101  
Macon, GA 31210  
USA  
Tel: +1 877 783 7337  
Fax: +1 478 476 9867  
e-mail: sales@verder-us.com