

Verderair VA-H40 FD

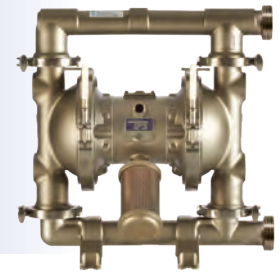

VA-H40 FD

VERDERAIR

Technische Daten			
Max. Fördermenge			443 l/min
Max. Druck			8 bar
Gewicht	Edelstahl-Ausführung		40,3 kg
	Edelstahl-/Aluminium-Ausführung		37,6 kg
Saughöhe	Trocken		4,3 mWs
	Produktberührt		8,8 mWs
Temperatur	Werkstoffe Kugeln/Membranen	Santoprene	-40 bis 82 °C
		PTFE; PTFE/EPDM (Verbund)	4 bis 104 °C
		Neoprene (Stahlkern)	-18 bis 93 °C
Max. Feststoffgröße			4,8 mm
Max. Viskosität			15.000 mPas
Zertifikate	Werkstoffe	PTFE /	EC1935/2004
	Kugeln/Membranen	PTFE/EPDM (2teilig)	
	Alle Modelle		FDA
	Alle Modelle		ATEX (Ex II 2 GD c T6)

Pumpenschlüssel VA-H25 Nr. 1 Nr. 2 Nr. 3 Nr. 4 Nr. 5 Nr. 6 Nr. 7

Nr. 1 Gehäuse

 S = Edelstahl 316, Ra: 3,2 µm

Nr. 2 Mittelteil

 S = Edelstahl 316, Ra: 3,2 µm

 A = Aluminium

Nr. 3 Ventilsitze

SE = Edelstahlsitz mit EPDM O-Ring

ST = Edelstahlsitz mit PTFE O-Ring

Nr. 4 Ventilkugeln

SP = Santoprene

 TF = PTFE

NW = Neoprene (Stahlkern)

Nr. 5 Membranen

SP = Santoprene

 TF = PTFE/EPDM (2teilig)

TO = PTFE/EPDM (Verbund)

Nr. 6 Anschlüsse

D5 = DIN 11851, DN50, Außengewinde

T5 = Tri-Clamp, 2"

Nr. 7 Ausführung

FD = FDA-Zertifiziert

BEISPIEL PUMPENSCHLÜSSEL

VA-H40SS ST TF TO D5 FD

Achtung: Nicht alle Kombinationen verfügbar



Ex II 2 GD c T6



EC1935/2004

Verderair VA-H40 FD

VA-H40 FD

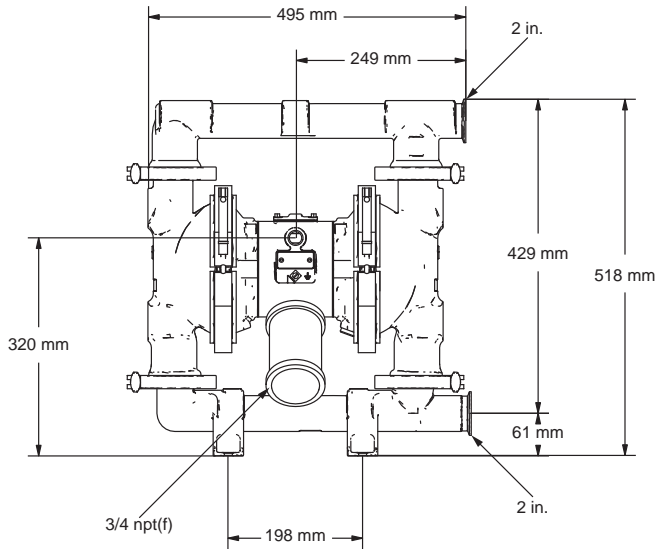

Mit
Tri-Clamp-Anschluss

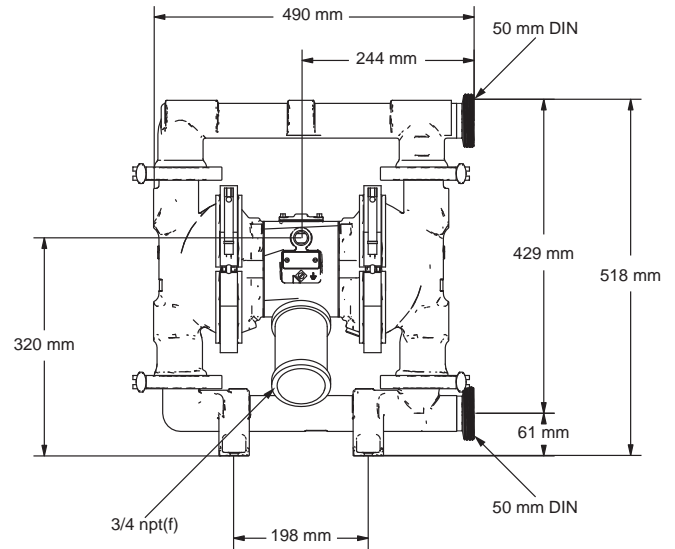

Mit
DIN-Anschluss

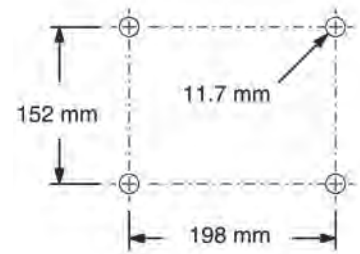
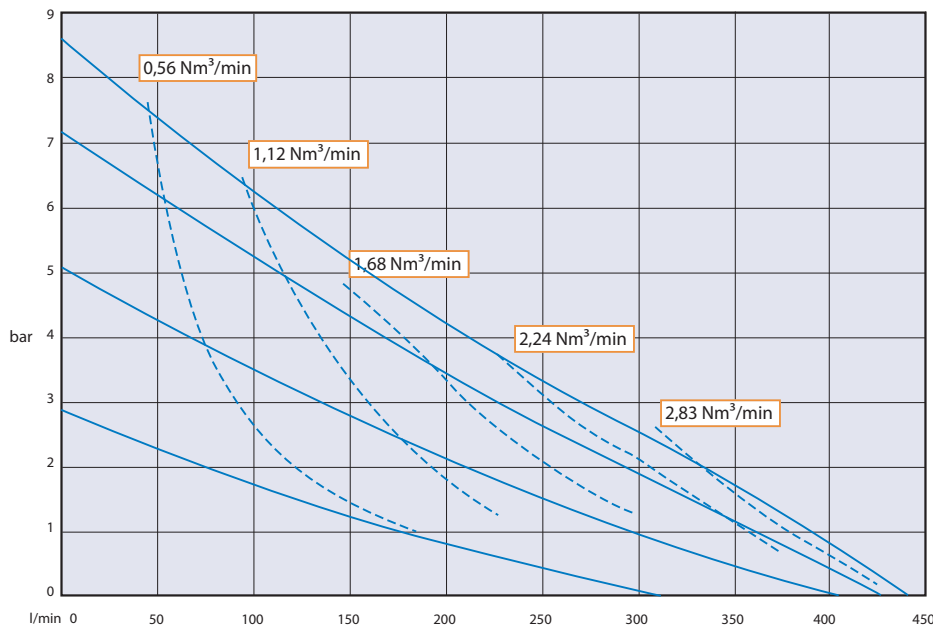

Stellfläche

Luftverbrauch



Rev-12-08-2014-DE

VERDER DEUTSCHLAND GmbH & Co. KG
 TEL +49 (0)2104 23 33-200
 MAIL info@verder.de
 WEB www.verder.de

VERDER GmbH AUSTRIA
 TEL +43 (0)1 865 10 74-0
 MAIL office@verder.at
 WEB www.verder.at

VERTRIEB SCHWEIZ
 TEL +41 (0) 61 331 33 13
 MAIL info@verder.ch
 WEB www.verder.ch

VERDER
 passion for pumps